

CONTRIBUTION OF GROUNDWATER TO CONSUMPTIVE USE OF UPLAND CROP

ACKNOWLEDGMENTS

The author wishes to express his sincere gratitude to his advisor, Dr. Apichart Anukularmphai, for his valuable suggestions and helpful guidance, together with Dr. Alan C. Early, Assoc. Agricultural Engineer, Department of Irrigation and Water Management of the International Rice Research Institute, who gave the suggestions and criticisms throughout his work.

Varawoot Vudhivanich

Gratitudes are also extend to Professor Fude I and Dr. Helmut Eggers for serving members of the thesis committee.

Grateful acknowledgements are due to the Government of Japan, the Royal Irrigation Department of Thailand and the International Rice Research Institute for their financial assistance, wherever possible.

A thesis submitted in a partial fulfillment of the requirements for the degree of Master of Engineering.

Special thanks are due to the officers of the Experimental and Demonstration Farm for Irrigated Agriculture, KALASIN PROVINCE and Mr. Somchai Juntarasert for their help throughout the field work.

Finally, thank is due to the Division of Water Resources Engineering, IIT, for the responsibility in producing this manuscript.

Examination Committee: Dr. Apichart Anukularmphai (Chairman)
Professor Fude I
Dr. Helmut Eggers
Dr. Alan C. Early

Varawoot Vudhivanich
Nationality: Thai
Previous degree: B.Eng., Kasetsart University, Thailand
Scholarship donor: Government of Japan

Asian Institute of Technology
Bangkok, Thailand
April, 1980

ACKNOWLEDGEMENTS

The author wishes to express his sincere gratitude to his advisor, Dr. Apichart Anukularmphai, for his valuable suggestions and helpful guidance, together with Dr. Alan C. Early, Associate Agricultural Engineer, Department of Irrigation and Water Management of the International Rice Research Institute, who gave the suggestion and supervision throughout his work.

Gratitudes are also extend to Professor Fude I and Dr. Helmut Eggers for serving members of the thesis committee.

Grateful acknowledgements are due to the Government of Japan, the Royal Irrigation Department of Thailand and the International Rice Research Institute for providing the scholarship which made this study possible.

Sincere thanks are due to the officers of the Experimental and Demonstration Farm for Irrigated Agriculture, KALASIN PROVINCE and Mr. Somchai Juntharasri for their help throughout the field work.

Finally, thank is due to the Division of Water Resources Engineering, AIT, for the responsibility in producing this manuscript.

Evapotranspiration of sweet corn was estimated about 15.0 cm. In contrast, when assumed the soil moisture depletion occurred from the soil surface to the capillary rise level, the water requirements were found to be 50.3 cm or 6.5 mm/day. The groundwater contribution to the evapotranspiration of WID1, WID2, WID3 and WID4 was 12.4, 12.2 and 9.5 cm, respectively, for F113 treatment. No salinity problem was encountered in the experimental site.

Maximum yield of 3,260 kg/ha was found at F113 of WID3-plot. As the inputs of water and fertilizer increased, the yield response of sweet corn increased and reached a maximum at F113, with an exception of WID2, which the maximum yield response was at F212 treatment. The explanation for very low yield is due to very poor soil structure. A high bulk density of 1.7 gm/cc limits vertical root development. Water deficits occurred during the critical period, even in the I3-treatment.

Water application efficiency showed that at the I3-treatment, the amount of water applied exceeded the maximum holding capacity of soil and losses occurred as deep percolation. To reduce this loss, the amount of water applied should be approximately 0.64 times evaporative demand.

TABLE OF CONTENTS

ABSTRACT

A field experiment was conducted in Lam Pao Irrigation Project on plots with five different water table levels, 52, 87, 104, 134, and 277 cm depth labelled WTD1, WTD2, WTD3, WTD4, and WTD5, respectively. The water table was allowed to fluctuate with the field condition, and dropped throughout the period of experiment, as much as 40 cm in WTD1 treatment. Three levels of irrigation were designated as I1, I2, and I3 corresponding to 0, 0.6, 1.2 time the evaporative demand. Three levels of fertility were designated as F1, F2 and F3 corresponding to 0, 0.6, 1.2 time the basic fertilizer rate. Irrigation was applied on the basis of 10 days interval.

The soil moisture depletion was measured on the basis of one day before and two days after irrigation by Neutron probe. Based on the soil moisture depletion study within the root zone, the water requirements of sweet corn were found to be 36.0 cm or 4.8 mm/day. The ratio of ET/Epan of F3I3 treatment ranged from 0.48 to 0.76. The soil moisture depletion of F3I3 indicated no significantly difference among WTD2, WTD3, WTD4 and WTD5, leading to the conclusion that no ground water was supplied to plants in those plots. For WTD1-plot with shallowest water table, the groundwater contribution to the evapotranspiration of sweet corn was estimated about 15.0 cm. In contrast, when assumed the soil moisture depletion occurred from the soil surface to the capillary rise level, the water requirements were found to be 50.3 cm or 6.6 mm/day. The groundwater contribution to the evapotranspiration of WTD1, WTD2, WTD3 and WTD4 was 32.4, 12.2 and 9.8 cm, respectively, for F3I3 treatment. No salinity problem was encountered in the experimental site.

Maximum yield of 3,260 kg/ha was found at F3I3 of WTD3-plot. As the inputs of water and fertilizer increased, the yield response of sweet corn increased and reached a maximum at F3I3, with an exception of WTD2, which the maximum yield response was at F2I2 treatment. The explanation for very low yield is due to very poor soil structure. A high bulk density of 1.7 gm/cc limits vertical root development. Water deficits occurred during the critical period, even in the I3-treatment.

Water application efficiency showed that at the I3-treatment, the amount of water applied exceeded the maximum holding capacity of soil and losses occurred as deep percolation. To reduce this loss, the amount of water applied should be approximately 0.84 times evaporative demand.

TABLE OF CONTENTS

TABLE OF CONTENTS (Continued)

<u>CHAPTER</u>	<u>TITLE</u>	<u>PAGE</u>
	Thesis Approval	i
	Acknowledgements	ii
	Abstract	iii
	Table of Contents	iv
	List of Tables	vii
	List of Figures	viii
	List of Appendices	ix
I	INTRODUCTION	1
II	LITERATURE REVIEW	3
	2.1 Groundwater in Relation to Evapotranspiration and Yield of Crops	3
	2.1.1 Soil Tank or Lysimeter Studies	3
	2.1.2 Field Condition Studies	5
	2.2 Related Tropics	6
	2.2.1 Consumptive Use	6
	2.2.2 Water Stress	7
	2.2.3 Root Development and Its Relation to Yield	8
III	METHODOLOGY	10
	3.1 Experimental Design	10
	3.1.1 Crop Selection	10
	3.1.2 Irrigation Treatments	10
	3.1.3 Fertility Treatments	10
	3.1.4 Water Table Depth (WTD) Treatments	10
	3.1.5 Split-Split-Plot Design	10
	3.2 Pre-experimental Methodology	10
	3.2.1 Description of Project Area - Lam Pao Irrigation Project	10
	3.2.2 Site Selection	11
	3.2.3 Soil Properties Determination	11
	3.2.4 Test of Irrigation Water and Groundwater	14
	3.2.5 Measurement of Evaporation and Rainfall	14
	3.2.6 Pump and Delivery Hose Calibration	14
	3.2.7 Neutron Moisture Meter Calibration	14
	3.3 Experimental Methodology	14
	3.3.1 Land Preparation	14
	3.3.2 Experimental Plot Layout and Access Tube - Observation Tube Installation	14
	3.3.3 Planting and Crop Cultural Practices	14
	3.3.4 Water Application	17

TABLE OF CONTENTS (Continued)

<u>CHAPTER</u>	<u>TITLE</u>	<u>PAGE</u>
	3.3.5 Soil Moisture Measurement and Groundwater Table Observation	17
	3.3.6 Height-Yield-Dry Matter and Root Measurement	18
	3.4 Analysis of Data	18
	3.4.1 Determination of the Calibration Equation for Neutron Probe	18
	3.4.2 Estimation of Soil Moisture Depletion	18
	3.4.3 Estimation of the Groundwater Contribution to Evapotranspiration of Crop	19
	3.4.4 Response of Yield VS Irrigation Water, Fertilizer and Water Table Depth	20
	3.4.5 Estimation of Water Application Efficiency (Ea)	20
	3.4.6 Estimation of Water Use Efficiency (MICHAEL A.M., 1978)	21
IV	PRESENTATION AND DISCUSSION OF RESULTS	22
	4.1 Meteorological Conditions	22
	4.2 Soil Analysis Results	22
	4.2.1 Soil Fertility	22
	4.2.2 Physical Properties of Soil	22
	4.2.3 Salt Problem in the Soil	25
	4.3 Groundwater Fluctuation	27
	4.4 Neutron Moisture Meter Calibration	27
	4.5 Inputs to Crop and Production Function	32
	4.5.1 Yield, Dry Matter and Height as Affected by Water Table Depth, Fertilizer and Irrigation Water	32
	4.5.2 Root Study	34
	4.5.3 Production Function	39
	4.6 Evapotranspiration and Groundwater Contribution to Evapotranspiration of Sweet Corn	40
	4.7 Water Application Efficiency	50
	4.8 Crop Water Use Efficiency and Field Water Use Efficiency	50
V	CONCLUSION	56
VI	RECOMMENDATION FOR FURTHER STUDY	57
	REFERENCES	58

TABLE OF CONTENTS (Continued)

<u>CHAPTER</u>	<u>TITLE</u>	<u>PAGE</u>	<u>PAGE</u>
	Soil Fertility		24
APPENDIX	Moisture and Particle Density, (gw/cc)	62	24
	Particle Size Distribution of Soil at Experimental Site		24
	Comparison of pH, EC and ESP of Soil, Before Planting and After Harvesting		26
	pH and EC of Irrigation Water and Groundwater		27
	Regression Coefficients and Statistical Parameters of Calibration Equations for Neutron Probe, $CR = A0 + A1 \cdot MC$, where CR is count ratio and MC is soil moisture in volume percentage		29
	Total Amount of Fertilizer and Irrigation Water Applied		32
	Regression Coefficients for the Production Function		39
	Regression Coefficients for the Production Function of WTD1, WTD2, WTD3, WTD4 and WTD5		40
3.12	Ratio of ET/Epan (Pan Factor), based on EMD within the root zone		51
3.13	Ratio of ET/Epan (Pan Factor), based on EMD of 120 cm soil profile		52
3.14	Water Application Efficiency		54
3.15	Crop Water Use Efficiency		55

LIST OF TABLES

<u>TABLE</u>		<u>PAGE</u>
4.1	Soil Fertility	24
4.2	Bulk Density and Particle Density, (gm/cc)	24
4.3	Particle Size Distribution of Soil at Experimental Site	24
4.4	Comparison of pH, EC and ESP of Soil, Before Planting and After Harvesting	26
4.5	pH and EC of Irrigation Water and Groundwater	27
4.6	Regression Coefficients and Statistical Parameters of Calibration Equations for Neutron Probe, $CR = A_0 + A_1 \cdot MC$, where CR is count ratio and MC is soil moisture in volume percentage	29
4.7	Total Amount of Fertilizer and Irrigation Water Applied	32
4.8	Regression Coefficients for the Production Function	39
4.9	Regression Coefficients for the Production Function of WTD1, WTD2, WTD3, WTD4 and WTD5	40
4.10	Ratio of ET/Epan (Pan Factor), based on SMD within the root zone	51
4.11	Ratio of ET/Epan (Pan Factor), based on SMD of 120 cm soil profile	53
4.12	Water Application Efficiency	54
4.13	Crop Water Use Efficiency	55
4.7(4)	Predicted Yield Response on Fertilizer and Irrigation Water Applied on WTD4-Plot	45
4.7(5)	Predicted Yield Response on Fertilizer and Irrigation Water Applied on WTD5-Plot	45
4.8	Bar Chart Showing the Comparison of the Soil Moisture Depletion (within the root zone) Among All Treatment Plots	47
4.9	Bar Chart Showing the Comparison of the Soil Moisture Depletion (from the soil surface down to the capillary rise level) Among All Treatment Plots	46
4.10	Curves Comparing Pan Factor of F313 Treatment and Crop Coefficient of Corn of JENSEN, M.K.	53

LIST OF FIGURES

<u>FIGURE</u>		<u>PAGE</u>
2.1	Evapotranspiration of Cotton as Affected by The Depth of Water Table (After BARAKET et al, 1972)	5
3.1	Sketch Showing the Experimental Area	12
3.2	Layout Plan	15
3.3	Access Tube and Observation Tube Installation	16
4.1	Daily Evaporation and Rainfall Observed at Experimental Site During The Entire Growing Season, Dry Season 1979	23
4.2	Ground Water Fluctuation Curve	28
4.3	Neutron Moisture Calibration Curve	30
4.4	Bar Chart Showing Yield, Dry Matter and Height Response to Water Table Depth, Fertilizer and Irrigation Water Applied	33
4.5	Dry Matter VS. Fresh Yield for All Combination Treatments of Fertilizer and Irrigation Water	35
4.6	Root Distribution Diagram	36
4.7(1)	Predicted Yield Response on Fertilizer and Irrigation Water Applied on WTD1-Plot	41
4.7(2)	Predicted Yield Response on Fertilizer and Irrigation Water Applied on WTD2-Plot	42
4.7(3)	Predicted Yield Response on Fertilizer and Irrigation Water Applied on WTD3-Plot	43
4.7(4)	Predicted Yield Response on Fertilizer and Irrigation Water Applied on WTD4-Plot	44
4.7(5)	Predicted Yield Response on Fertilizer and Irrigation Water Applied on WTD5-Plot	45
4.8	Bar Chart Showing the Comparison of the Soil Moisture Depletion (within the root zone) Among All Treatment Plots	47
4.9	Bar Chart Showing the Comparison of the Soil Moisture Depletion (from the soil surface down to the capillary rise level) Among All Treatment Plots	48
4.10	Curves Comparing Pan Factor of F313 Treatment and Crop Coefficient of Corn of JENSEN, M.E.	53
	Photograph A1 Root Distribution	82

LIST OF APPENDICES

<u>APPENDIX</u>		<u>PAGE</u>
Table A1	Daily Evaporation and Rainfall Observed at Experimental Site During the Entire Growing Season, Dry Season 1979	62
Table A2	Groundwater Table Record at Experimental Site During February, April 1979	63
Table A3	Height of Sweet Corn under Different Water Table Depth, Irrigation and Fertility Treatments	64
Table A4	Yield of Sweet Corn under Different Water Table Depths, Irrigation and Fertility Treatments	65
Table A5	Dry Matter of Sweet Corn under Different Water Table Depths, Irrigation and Fertility Treatments	67
Table A6	Root Weight of Sweet Corn under Different Water Table Depths, Irrigation and Fertility Treatments	69
Table A7(1)	Total and Mean Soil Moisture Depletion for WTD1	71
Table A7(2)	Total and Mean Soil Moisture Depletion for WTD2	72
Table A7(3)	Total and Mean Soil Moisture Depletion for WTD3	73
Table A7(4)	Total and Mean Soil Moisture Depletion for WTD4	74
Table A7(5)	Total and Mean Soil Moisture Depletion for WTD5	75
Table A8(1)	Total and Mean Soil Moisture Depletion for WTD2	76
Table A8(2)	Total and Mean Soil Moisture Depletion for WTD3	77
Table A8(3)	Total and Mean Soil Moisture Depletion for WTD4	78
Table A8(4)	Total and Mean Soil Moisture Depletion for WTD5	79
Table A9	Estimated ETo and ETc from Epan (class A) by Using Pan Coefficient (Kp) and Crop Coefficient (Kc) Recommended by FAO <u>1/</u>	80
Fig. A1(1) - A1(5)	Infiltration Rate Curve	82-86
Fig. A2(1) - A2(2)	Soil Moisture Characteristic Curve	87-88
Fig. A3(1) - A3(15)	Diagram Showing the Available Percent of Soil Moisture with the Input of Irrigation Water	89-103
Photograph A1	Root Distribution	104

I. INTRODUCTION

Soil moisture is one of the main natural elements for plant growth. For centuries, human being have tried to control the water to plants where and when the natural conditions of the moisture regime are unsatisfactory. Irrigation is an artificial application of water under man's control to provide the best possible soil moisture content required for the desired growth of plants. Moreover, having an ample water available for crops, contributes to profitable agricultural production.

Irrigation water is supplied to supplement water available from the following sources, precipitation, atmospheric water other than precipitation, flood water and groundwater, none of which should be ignored when irrigation water requirements are estimated. Failure to consider all four sources and the proportion of water that each supplies to total plant needs may result in faulty design of irrigation systems. In some areas, one or more of the four sources may contribute appreciable amounts of water to the plants (ISRAELSEN and HANSEN, 1962).

Groundwater is the water beneath the soil surface where voids in the soil are substantially filled with water. In the shallow water table region, upward movement of groundwater by capillarity from the water table into the root zone can be a major source of water for plant growth. Crops may obtain a significant portion of their needed water from the saturated soil where the water table is within 1 m (KRAMER, 1969). As much as 50% can come from groundwater without seriously restricting growth. Saving the cost of applying 20 to 50 percent of normally needed irrigation water may more than offset the reduction of production resulting from a somewhat higher water table (ISRAELSEN and HANSEN, 1962). However, the supply of water by capillarity to the plants is limited by the depth of water table and this limit varies with the soil texture (KEEN, 1972).

A knowledge of water supply by capillarity from groundwater is very useful in planning, design and operating an irrigation scheme, particularly in the dry season when the cultivation always faces a limitation of water supply. The reduction in irrigation water requirements is desirable for irrigation managers because the same amount of water can irrigate a wider area.

Lam Pao Irrigation Project in KALASIN PROVINCE has several crops, other than rice, been grown during the dry season. Major areas of the project also have high water table condition such that the irrigation water requirements are appreciably affected (ABDALLA, 1974 and POOMVISES et al, 1963). Irrigation managers require information such as groundwater supply to plants, crop water requirements for proper scheduling. Likewise the response to water and fertility inputs as yield is important information for extension personnel to covey farmers growing dry season upland crops such as corn, mung bean, melon and peanut.

Objectives of the Study

Sweet corn was selected as a dry season crop commonly grown in the shallow water table area of Lam Pao Irrigation Project in order to

1. To estimate the contribution of groundwater to crop consumptive use with respect to water table depth.
2. To estimate crop yield response with respect to water table depth, amount of irrigation water and amount of fertilizer applied.
3. To estimate seasonal irrigation application efficiency with respect to water application and rooting depth of crop.

2.1.1 Soil Tank or Lyimeter Studies

VAN SCHILFEGARDE and WILLIAMSON, (1956) reported that the yields of soybean, kidney and fescue responded to the aeration status of the root zone and/or the availability of the moisture rather than the water table depth and the effect of daytime temperature must be carefully considered. The maximum yields of soybean and sweet corn were obtained at 45.5 to 51.0 cm and 76.2 to 86.4 cm of water table depth, respectively. They also stated that the yields generally increased as the depth to water table increased to an optimum value. Apparently the soil in the vicinity of most of the root became too dry to sustain maximum growth when the water table depth was beyond the optimum.

When the water table was maintained at 15, 30.5 and 51 cm below the soil surface, GILBERT and CHAMBLER (1959), found that without surface watering, Ladino Clover, orchardgrass, and tall fescue produced 29, 54, and 75 percent more, respectively, with 15 cm water table depth than with 30.5 and 51 cm water tables. With 2.54 cm of surface water per week, a large increase in yields of orchardgrass and tall fescue was obtained with the lower water tables, and a depression with 15 cm water tables, but Ladino Clover had a little difference in yield with water tables.

KLAGES and ALENSON (1959) reported that hay yield response to nitrogen (100 lb/acre annually) increased with increasing water table depth. The increase due to nitrogen was 4 times as great with 51 cm water table depth as with the surface water table.

WEAVER and STEPHENS (1963) reported that the evapotranspiration of pepper was equal to 3.4, 2.5 and 2.1 mm/day corresponding to the water table depths of 30.5, 45.7 and 51 cm. It was concluded that the difference in evapotranspiration was induced by the moisture tension differences.

WILLIAMSON and WILLEY (1964), in the greenhouse, found that the yield of Kentucky 31 fescue was approximately the same for water table depths of 23 and 43 cm, but reduced considerably with a water table depth of 74 cm when no surface watering was practiced. In the growth chamber experiment, the maximum yield was obtained at a water table depth of 46 cm, which

II LITERATURE REVIEW

2.1 Groundwater in Relation to Evapotranspiration and Yield of Crops

Many endeavors have attempted to utilize the groundwater in agriculture, realizing that the contribution from groundwater to root of plants occurred if the water table level come close enough to the root zone. The question is how close and how much plants can utilize the ground water to produce the maximum yield. Answers depend largely on the conditions of soil, plant, climate and amount and method of irrigation. Most of the work reported were done in lysimeters for which the water table could be controlled, but very little work done in the field conditions where elements of the nature could not be controlled.

2.1.1 Soil Tank or Lysimeter Studies

VAN SCHILFGAARDE and WILLIAMSON, (1956) reported that the yields of soybean, kidney and fescue responded to the aeration status of the root zone and/or the availability of the moisture rather than the water table depth and the effect of daytime temperature must be carefully considered. The maximum yields of soybean and sweet corn were obtained at 45.5 to 61.0 cm and 76.2 to 86.4 cm of water table depth, respectively. They also stated that the yields generally increased as the depth to water table increased to an optimum value. Apparently the soil in the vicinity of most of the root became too dry to sustain maximum growth when the water table depth was beyond the optimum.

When the water table was maintained at 15, 30.5 and 51 cm below the soil surface, GILBERT and CHAMBLEE (1959), found that without surface watering, Ladino Clover, orchardgrass, and tall fescue produced 20, 54, and 71 percent more, respectively, with 15 cm water table depth than with 30.5 and 51 cm water tables. With 2.54 cm of surface water per week, a large increase in yields of orchardgrass and tall fescue was obtained with the lower water tables, and a depression with 15 cm water tables, but Ladino Clover had a little difference in yield with water tables.

KLAGES and ASLENSON (1959) reported that hay yield response to nitrogen (100 lb/acre annually) increased with increasing water table depth. The increase due to nitrogen was 8 times as great with 61 cm water table depth as with the surface water table.

WEAVER and STEPHENS (1963) reported that the evapotranspiration of pepper was equal to 3.4, 2.5 and 2.1 mm/day corresponding to the water table depths of 30.5, 45.7 and 61 cm. It was concluded that the difference in evapotranspiration was induced by the moisture tension differences.

WILLIAMSON and WILLEY (1964), in the greenhouse, found that the yield of Kentucky 31 fescue was approximately the same for water table depths of 23 and 43 cm, but reduced considerably with a water table depth of 74 cm when no surface watering was practiced. In the growth chamber experiment, the maximum yield was obtained at a water table depth of 40 cm, which

was highly different from the yield of 20 and 60 cm water table depths. This results were explained on the basis of the root distribution. The fescue root system was predominately in the upper layer of the soil, 90% of the roots were in the upper 10 cm of the soil. The reduction in yield with the 20 cm water table depth was attributed to leaching nitrogen from the root zone while with the 60 cm water table depth was caused by a moisture deficit.

TOVEY (1964) found consumptive use and yield of alfalfa with a static water table regardless of soil textures almost followed a straight-line relationship, decreased as water table increased from 61 cm to 244 cm when no irrigation water was applied. With fluctuating water table, the yield was maximum at 2 days inundation interval, thereafter the yield decreased to almost zero for 9 days inundation interval and reversed for 11 days interval. Root study showed that root deterioration became progressively worse as a water logging exceeded 4 days. It was concluded that excess water should be removed from the root zone of alfalfa adapted to a 61 cm static water table within 3 days to ensure the optimum crop production.

GOIN, LUNIN and WORLEY (1966) studied the effect of water table on growth of tomatoes, snap beans and sweet corn in the greenhouse in soil columns of loamy fine sand, loam and silty clay loam, where the water tables were maintained at 15.2, 30.5, 45.7, 61.0 and 81.3 cm depth. Tomatoes and sweet corn produced significantly more dry matter with increasing water table depths, with the exception of sweet corn grown on silty clay loam. Yields of snap beans increased as the depth of water table increased only on loamy fine sand. The total water used generally increased linearly with the amount of dry matter produced.

WILLIAMSON (1968) found that without surface watering the yield and evapotranspiration of stringbean in fine sandy loam were maximum at water table depth of 30.5 cm and both were reduced at deeper or shallower water table depth. When surface watering was applied to the soil with shallow water table depth, the oxygen content was reduced and caused a root injury or root growth reduction and, subsequently, a reduction in yield. The maximum yield was found at 60 to 75 cm water table depth. WILLIAMSON and CARRECKER (1970) stated that both evapotranspiration and yield of plants were affected by the depth of water table, soil types and method of watering. WILLIAMSON and KRIZ (1970) stated that coarse-textured soils usually require a higher water table for optimum yield than do fine-textured soil. A lower water table usually gives optimum yield in all soil types when combined with surface watering.

BARAKAT et al (1972) showed that the contribution from groundwater to evapotranspiration of cotton tended to decline steeply as the depth of water table increased to 100 cm, then gently towards the 160 cm depth (Fig. 2.1). With additional water from irrigation water and from groundwater, the difference in evapotranspiration due to water table depth became narrow but still appreciable. Cotton yields were found increasing at constant steep slope as the depth of water table to 100 cm, afterward the slope tended to decline. They also suggested that the maximum water use efficiency by cotton was at 100 cm water table depth.

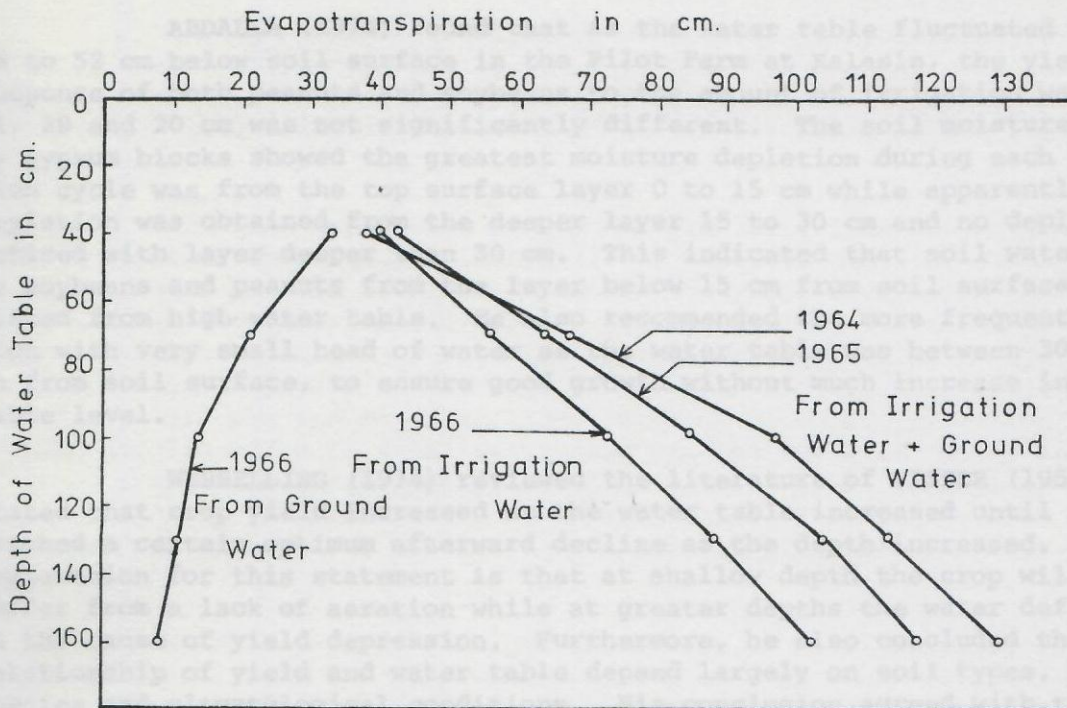

Fig 2.1 Evapotranspiration of Cotton as Affected by The Depth of Water Table (After BARAKET et al, 1972)

2.1.2 Field Condition Studies

EDEN et al (1951) and NICHOLSON and FIRTH (1953) found that maximum yields in peat soils were obtained with a high water table (40-60 cm depth) in dry years, whereas in wet years the opposite result were obtained.

WESSELLING and VAN WIJK (1957), when reviewed the literature of HOOGHOUT (1952), stated that the higher the difference between the evapotranspiration and rainfall, the higher the relative crop yields with shallow depths of water table. This is due to the better aeration in dry years, and partly to uptake of water from groundwater.

VAN HOORN (1958) reported that crop yields were closely related to the total amount of nitrogen present in the root zone and that much of the reduction in yield associated with high water tables could be overcome by the addition of extra nitrogen.

LAL and SHARMA (1973), under fluctuating water table between 125 to 171 cm from soil surface, found that the dwarf wheat yield was not significantly different with the different soil moisture regimes (100 to 75 %, 100 to 50 % and 100 to 25 % of available moisture). Lack of response to moisture may be because of an irrigation at crown-root-initiation and high water table. They also concluded that the irrigation requirement of wheat would vary according to the water table depth.

ABDALLA (1974) found that as the water table fluctuated between 48 to 52 cm below soil surface in the Pilot Farm at Kalasin, the yield response of both peanuts and soybeans to the amount of irrigation water of 41, 28 and 20 cm was not significantly different. The soil moisture measured by gypsum blocks showed the greatest moisture depletion during each irrigation cycle was from the top surface layer 0 to 15 cm while apparently little depletion was obtained from the deeper layer 15 to 30 cm and no depletion was noticed with layer deeper than 30 cm. This indicated that soil water used by soybeans and peanuts from the layer below 15 cm from soil surface was replaced from high water table. He also recommended the more frequent irrigation with very small head of water as the water table was between 30 and 65 cm from soil surface, to ensure good growth without much increase in water table level.

WESSELLING (1974) reviewed the literature of VISSER (1958) and stated that crop yield increased as the water table increased until it reached a certain optimum afterward decline as the depth increased. His explanation for this statement is that at shallow depth the crop will suffer from a lack of aeration while at greater depths the water deficiency is the cause of yield depression. Furthermore, he also concluded that the relationship of yield and water table depend largely on soil types, plant species and climatological conditions. His conclusion agreed with the lysimeter study.

2.2 Related Tropics

2.2.1 Consumptive Use

Consumptive use is defined as the total amount of water taken by plants for transpiration, building of plant tissue, plus the unavoidable evaporation of soil moisture, snow and intercepted precipitation associated with plant growth (HUSCKLE, 1959). A knowledge of consumptive use is essential for estimating the irrigation water requirements which are necessary in planning, designing and operating water resource development, particularly in arid and semi-arid irrigated area or in dry season irrigation.

Many attempts and methods have been reported for centuries to determine the term "consumptive use" of crops. The principle methods can be classified as lysimeter experiments, field experimental plots, soil moisture depletion studies and water balance studies. Since the consumptive use has a close relation with the climatological conditions and the evaporation from an open pan, so it can be easily calculated from the climatological data or from the pan evaporation data.

WIDTSOE (1912) measured the consumptive use in field experimental plots and reported that crop yield has a close relation with the total water used. In most crops, yields were found to increase rapidly with an increase of water used to a certain point, then decreased as the amount of water increased. He concluded that the amount of water used to obtain the maximum yield was considered as the consumptive use of crops.

LAL and SHARMA (1973) reported that the evapotranspiration (ET) of wheat was significantly correlated with USWB class A pan evaporation (E_o) when the crop was in an active stage of growth and soil moisture was not limited, and soil moisture depletion of 25 to 50 percent of available moisture was allowed.

In field experiment at the Lam Pao Irrigation Project, without effect of the groundwater, TALUKDER (1978) reported that the water requirements estimated by soil moisture depletion study for sweet corn and mungbean were 53.6 and 20.0 cm respectively. A pan coefficient 1.2 for sweet corn and 0.6 for mungbean found to be the best suited for estimating irrigation timings. Maximum yields of 7207 and 1264 kg/ha were obtained at I5F5 treatment for sweet corn and mungbean (I5F5 is 44 cm of total irrigation water applied and 750 kg/ha of total fertilizer applied for sweet corn, and 30 cm of total irrigation water applied and 330 kg/ha of total fertilizer applied for mungbean). However, the I3F3 treatment (half of I5F5) for both crops could be used since there was small variation in yield between this two treatments.

HARROLD (1955) obtained the result of field moisture observation by gypsum blocks that the evapotranspiration rate of sweet corn built up to a maximum of 6.9 mm/day for a 4-day period and 6.4 mm/day for a 6-day period in July. Average for the month was probably less than 4.8 mm/day. He concluded that the maximum depth of soil to be considered for irrigation of sweet corn should be 36 cm because most of the soil moisture was extracted from top 36 cm of soil.

HOLMES and ROBERTSON (1963) reported that under low evaporative conditions, actual evapotranspiration (AE) will equal to potential evapotranspiration (PE) until the moisture transport to and through the drying surface and/or to roots break down. Then AE sharply decreases, relative to PE, in exponential fashion. However, under high evaporative conditions the moisture transport system may break down very early regardless of the moisture content. HARROLD et al (1959) reported that as much as 50% of the total evapotranspiration of corn could be accounted for by evaporation from soil.

2.2.2 Water Stress

Plant growth is controlled directly by plant water stress and only indirectly by atmospheric and soil moisture status. Plant water stress occurs when the loss of water in transpiration exceeds the rate of absorption of water. In climates with bright sunshine and high temperature, a water stress may conceivably arise either due to deficit or an excess of water (LEVIT, 1972). Long term and more severe water deficits develop when decreases in soil water potential and hydraulic conductivity, cause decreased absorption of water. Therefore, daily water deficits are controlled by transpiration, but long term and severe water deficits which cause the largest reduction in plant growth are controlled by decreasing availability of soil moisture (KRAMER, 1969).

Water stress effects practically every aspect of plant growth; anatomy, morphology, physiology, biochemistry and etc. Some of the effects are related to the decrease in turgor, some to the decrease in water potential and perhaps to the decrease in osmotic potential. The quantitative effects on the reduction in growth are uncertain (KRAMER, 1969).

DENMEAD and SHAW (1962) found that transpiration and growth of corn were limited by soil moisture content at a higher level on sunny days with high transpiration than on cloudy days when transpiration rates are low. At low atmospheric demand (ratio of ET to Epan less than 0.2) the water could be furnished at relatively low soil water content in the root zone as SHAW and LAING (1965), while at high demand (ratio of ET/Epan over 0.3) the evapotranspiration rate decreased rapidly with moisture content below field capacity. HAGEN (1957) reported that Ladino clover under growth chamber conditions showed a little change in the rate of photosynthesis until the plants began to show visible signs of moisture stress near the permanent wilting point. HILER (1969) found that when used tensiometer readings at depth 15 and 30 cm for irrigation timing, the yield of sorghum in treatment of 30 cm depth of tensiometer reduced considerably since water stress in the early season due to root development.

There are general agreement that water stress at certain critical stage in plant growth causes more injury than other stages. The critical period of corn is the period from tesselling to silking stage (DENMEAD and SHAW, 1962; ROBINS and DOMINGO, 1953), at this period the water usage by corn was found by HOLT and DOREN (1961) to be the greatest and then dropped sharply after kernel formation.

When moisture was applied to corn by allowing moisture depletion to the permanent wilting point throughout the root zone, DENMEAD and SHAW (1960) reported that moisture stress at vegetative stage (30 days after planting) reduced grain yield by 25%. Moisture stress at silking stage (from tessel emergence till 5 days after plants were 75% silked) reduced a grain yield by 50% and moisture stress at ear stage (30 days beyond the silking period) reduced grain yield by 21%. The interaction of stresses between different growth stages were not statistically significant.

2.2.3 Root Development and Its Relation to Yield

The root system plays a major role in the absorption of water. Plants with a shallow and sparsely branched root system such as potatoes, onion, lettuce and etc., suffer sooner than deeper rooted species like alfalfa, maize, tomato and etc., (KRAMER, 1969). Root growth is closely related with environments and varies widely among species (TURNER, 1938; BENNETT and DOSS, 1960). The principal vertical root of corn, sometimes, penetrated downward at remarkable rate of 5 to 6.25 cm/day in the first 3 to 4 weeks, but the shoots were probably growing twice as rapid as this time (WEAVER, 1925). Those of sweet corn extend laterally more than half as far as the stalk extends upward, and the root depth is equal to height of the stalk (WEAVER and CLEMENTS, 1938).

In well-aerated soils in the temperate zone, KRAMER (1969), stated that the root growth is controlled by soil water supply and temperature.

Most of the rooting occurs in the spring and early summer when the soil moisture is optimum and in early autumn after rains. Growth is reduced or sometimes stopped by soil water deficiency in midsummer and by low temperature in the winter. To some extent, this is related to the time of year, and is affected by mineral nutrition or other cultural practices to which the seedlings were subjected prior to transplanting.

Where other factors are the same, roots penetrate more deeply and widely in the loose soil than those in the compact structure (DIEBOLD, 1935). Layer of compacted soil often play an important part in shaping the root system. Roots frequently fail to penetrate a dense layer because of its moisture content. Inadequate aeration may be greater influence more than soil strength on root penetration when it is wet, but when it is dry, soil strength increases sharply and mechanical impedance rather than gas diffusion rate becomes the limiting factor for root growth (TAYLOR and BURNETT, 1964). Soil bulk density in relation to soil moisture and texture is commonly used as an index of compaction. PHILLIPS and KIRKHAM (1962a, b) identified mechanical impedance as the physical property with reduction in depth of corn seedling root penetration. Growth of corn on clay soil was essentially stopped at a bulk density of 1.3 gm/cc. Similarly, mechanical impedance inhibited cotton seedling root penetration on sandy clay loam at bulk density of over 1.5 gm/cc and no penetration occurred in this soil at bulk density of 1.9 gm/cc, even though moisture was at field capacity (TACKETT and PEARSON, 1964). The critical values of bulk density ranged from 1.46 to 1.63 gm/cc (WEIRSMAN, 1959).

Tillage operations with large and heavy farm machinery tend to compact soils. In plowing for cultivation of crops on heavy soil, the depth of plowing should be varied from year to year so that a too firm layer will not develop at a certain depth and tend to confine root development to the plow layer (JENSEN, 1918).

The rate of absorption of water by plants depends on several factors such as available soil water and soil aeration. PANDEY and SINHA (1972) found that when moisture fall between field capacity and permanent wilting point, the absorption rate is generally uniform. With an increase of water beyond field capacity, aeration of soil was affected which reduced the rate of absorption. Raising the water table even temporarily by irrigation caused the death of the deeper roots in many plants since lack of aeration, was usually associated with the reduction of yield (WEAVER and CLEMENTS, 1938). GINGRICH and RUSSELL (1956) reported that as the soil moisture tension increased from 1 to 12 atm, the increase in radicle elongation, fresh weight, dry weight and degree of seedling hydration were progressively small.

RUSSELL, et al (1940) used tensiometers installed at intervals to a depth of 60 inches to measure the pattern of moisture extraction under corn. They found that moisture was first absorbed at a shallow depth directly beneath the corn root hill and extended laterally in the zone of absorption until most of the available moisture near the surface was depleted. Moisture was then extracted from the deeper layer in the same manner as the season progressed.

III METHODOLOGY

3.1 Experimental Design

3.1.1 Crop Selection - Sweet corn, variety Thai Super Sweet DMR#1, which is popular and suitable for sandy soil in Northeastern Thailand was selected for the experiment. It was sown at a spacing of 75 cm between row and 25 cm within row. The complete fertilizer, 15-15-15 of $N-P_2O_5-K_2O$, was used with the basic rate 625 kg/ha (100 kg/rai).

3.1.2 Irrigation Treatments - Three irrigation treatments were designated as I1, I2, and I3. The amount of irrigation water applied for I1, I2 and I3 was determined on the basis of the evaporative demand, which was defined as the amount of water lost by class A pan evaporation minus rainfall during each irrigation interval. Multiplying the coefficients 0.0, 0.6 and 1.2 for I1, I2 and I3, respectively, by the evaporative demand, the amount of irrigation water could be estimated.

3.1.3 Fertility Treatments - Similar to the irrigation treatments, the coefficients 0.0, 0.6 and 1.2 were assigned to three levels of fertility treatments F1, F2 and F3 respectively. The amount of fertilizer applied was calculated by multiplying these coefficients by the basic rate. Half of the amount calculated for each treatment was applied by broadcasting at the time of planting and another half by band placement at 3 weeks after planting (just after stand thinning).

3.1.4 Water Table Depth (WTD) Treatments - Five different water table depths namely; WTD1, WTD2, WTD3, WTD4 and WTD5; were selected on sloping land where the initial depth of WTD1, WTD2, WTD3, WTD4 and WTD5 were approximately 34, 71, 85, 130 and greater than 240 cm, respectively. The first four WTD were in the same area, but WTD5 was nearly at about 100 m distance. The water table was allowed to fluctuate with the field condition appearing to be 69, 110, 125, 144 and 279 cm deep from the soil surface for WTD1, WTD2, WTD3, WTD4 and WTD5, respectively, at the end of the growing season. The average depths of WTD1, WTD2, WTD3, WTD4 and WTD5 were corresponding to 52, 87, 104, 134 and 277 cm.

3.1.5 Split-Split-Plot Design - The experiment was designed as a Split-Split-Plot-Design with 3 replications. Five levels of water table depth, three levels of fertilizer and three levels of irrigation were designated as main plots, sub-plots and sub-sub-plots, respectively. Fertility treatments were arranged randomly in the main plot while irrigation treatments were randomized in each sub-plot.

3.2 Pre-experimental Methodology

3.2.1 Description of Project Area - Lam Pao Irrigation Project
The land has an undulating topography with position alternating swamps, sloping land and upland alternatively. Two types of soil are generally found in the project near Kalasin Province. Roi-et soil series is most commonly found in the low lying flat area and Korat soil series is generally

found on the sloping lands and uplands. Most of the soils existing in the project area are characterized by low productivity as proven by the very low yields without fertilization.

The Lam Pao Irrigation Project is situated on latitude $16\frac{1}{3}^{\circ}$ north of the equator and longitude $103\frac{1}{2}^{\circ}$ which places it in the tropical zone. Two distinct seasons are recognized as rainy and dry season. The rainy seasons starts from May and extends to the end of October and the dry season continues from November to the end of April. An average annual rainfall somewhat exceeds 1100 mm, 85 percent of which occurs in rainy season. The temperature range during January to April is from 20 to 30 degree centigrade and humidity is from 75 to 85 percent. Annual evaporation is about 2000 mm. The climatic classification is semi-arid.

Many places in the project area has water table level high enough to act as sub-surface water supply to plants. The fluctuation of water table occurs throughtout the dry season. The groundwater in general is not saline.

3.2.2 Site Selection - The experimental area was selected by the following criteria:

a) Sloping land which has a water table at approximately 30, 60, 90, 120 and 240 cm deep from the soil surface and all sites must be closed together.

b) Near a source of water which can supply water continuously during the period of experiment and can be used as a source considered.

c) Soils should be a representative of the Northeast soils and the variation of soils from place to place within the site must be minimal.

The contour map and groundwater contour map of the Pilot Farm Project were studied to locate the area satisfying the first two criteria. Auger holes were made to observe the water table in the area initially located on the map. The area between the left main canal of Lam Pao Irrigation Project and the left main canal of Huay Si-Thon Irrigation Tank (unlined), and another area on the other side of left main canal of Huay Si-Thon have landscape, water supply and the water table satisfying with the first two criteria. The soil was analyzed as loamy sand and the profile resembles all the physical and chemical properties of the Korat soil series. The site was located near the left main canal of the Lam Pao Irrigation Project (Huay Si-Thon) on land satisfying all three criteria (Fig. 3.1).

3.2.3 Soil Properties Determination

a) Soil Physical Properties

Bulk Density - Samples from every 15 cm layer of soil from the soil surface down to the water table level were collected from the five WTD-plots. By using core samplers, the samples were considered as undisturbed samples. All the soil samples were dried at 25°C for 24 hours. Bulk density was calculated based on the definition as ratio of

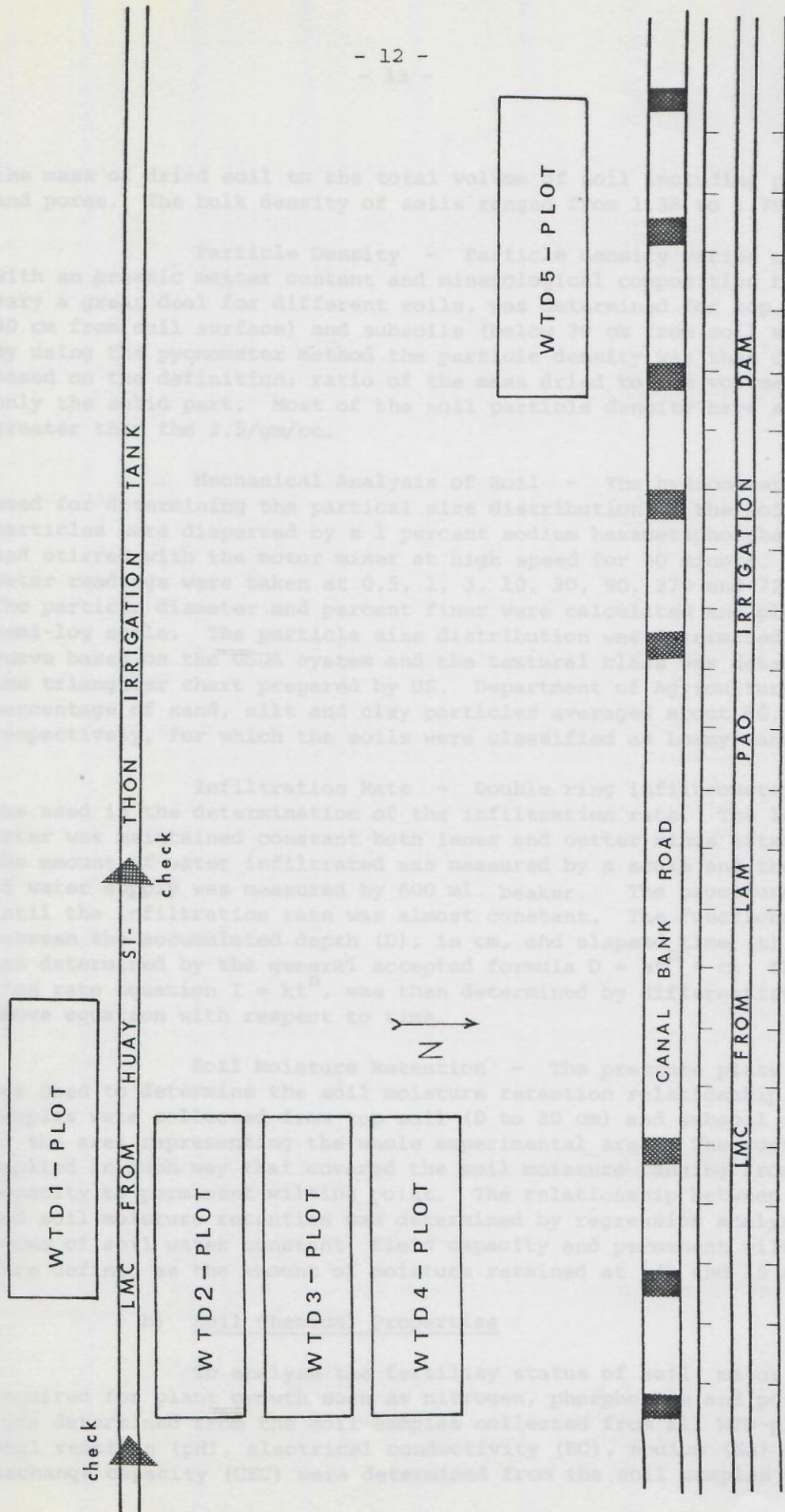

Fig 3.1 Sketch Showing the Experimental Area

the mass of dried soil to the total volume of soil including particles and pores. The bulk density of soils ranged from 1.38 to 1.79 gm/cc.

Particle Density - Particle density varies considerably with an organic matter content and mineralogical composition but does not vary a great deal for different soils, was determined for top soils (0 to 30 cm from soil surface) and subsoils (below 30 cm from soil surface). By using the pycnometer method the particle density was then calculated based on the definition; ratio of the mass dried to the volume of soil only the solid part. Most of the soil particle density have a value greater than the 2.5/gm/cc.

Mechanical Analysis of Soil - The hydrometer method was used for determining the partial size distribution of the soil. Soil particles were dispersed by a 1 percent sodium hexametaphosphate solution and stirred with the motor mixer at high speed for 30 minute. The hydrometer readings were taken at 0.5, 1, 3, 10, 30, 90, 270 and 720 minutes. The particle diameter and percent finer were calculated and plotted on a semi-log scale. The particle size distribution was determined from the curve based on the USDA system and the textural class was determined from the triangular chart prepared by US. Department of Agriculture. The percentage of sand, silt and clay particles averaged about 86, 7 and 7, respectively, for which the soils were classified as Loamy sand.

Infiltration Rate - Double ring infiltrometer method was used in the determination of the infiltration rate. The level of water was maintained constant both inner and outer rings after readings. The amount of water infiltrated was measured by a scale and the amount of water supply was measured by 600 ml. beaker.. The procedure was repeated until the infiltration rate was almost constant. The functional relationship between the accumulated depth (D), in cm, and elapsed time (t), in minute, was determined by the general accepted formula $D = at^b + c$. The infiltration rate equation $I = kt^n$, was then determined by differentiating the above equation with respect to time.

Soil Moisture Retention - The pressure plate apparatus was used to determine the soil moisture retention relationship. The soil samples were collected from top soil (0 to 30 cm) and subsoil (below 30 cm) of the area representing the whole experimental area. The suction was applied in such way that covered the soil moisture ranging from field capacity to permanent wilting point. The relationship between the suction and soil moisture retention was determined by regression analysis. The terms of soil water constant, field capacity and permanent wilting point, were defined as the amount of moisture retained at 1/3 and 15 atm.

b) Soil Chemical Properties

To analyse the fertility status of soil, major elements required for plant growth such as nitrogen, phosphorous and potassium were determined from the soil samples collected from all WTD-plots. The soil reaction (pH), electrical conductivity (EC), sodium (Na) and cation exchange capacity (CEC) were determined from the soil samples taken both

before planting and after harvesting to analyse the salt status.

3.2.4 Test of Irrigation Water and Groundwater - The pH and EC were determined from the water samples collected from the irrigation ditch and from the observation tubes both before planting and after harvesting for the water quality study.

3.2.5 Measurement of Evaporation and Rainfall - USWB class A evaporation pan and standard non-recording raingage were installed at the experimental site to record the evaporation and rainfall throughout the period of experiment. The readings were taken on daily basis at 8 A.M.

3.2.6 Pump and Delivery Hose Calibration - A pump and delivery hose used for applying the water was calibrated in a field condition. A 200 liter oil drum was placed in such way that top of the drum was at the soil surface. By counting the time for filling the drum, the rate of water delivery was calculated. The calibration was done individually for each WTD plots, as occurred at a different elevation above the water supply level.

3.2.7 Neutron Moisture Meter Calibration - Twelve representative sites were selected around the experimental area for the calibration work, with two chosen on the driest area. Water was applied differentially to obtain a range of moisture content. A surplus water was applied for two sites to make sure that this calibration will cover the moisture range near field capacity. The average of four one minute readings was recorded for each 15 cm layer to 90 cm depth. The direct measurement of soil moisture was done by gravimetric sampling, four replications for each layer. The bulk density was also determined. The relationship between the readings and soil moisture will be discussed later.

3.3 Experimental Methodology

3.3.1 Land Preparation - The experiment was carried out in dry season 1979, on the farmer's field. The land was prepared during January 24-28, by using a farm tractor drawn "Rotavator" and repeated twice to get rid of the residual rice straw. The plough layer was about 10 to 20 cm deep. After using the rotavator, the land was slightly levelled by a buffalo drawn "float".

3.3.2 Experimental Plot Layout and Access Tube - Observation Tube Installation. ² The experimental plot was prepared as shown in Fig.3.2 A 3.75 x 5.00 m² plot size was prepared with level furrow the aluminum access tube of 5.0 cm diameter and the PVC observation tube of 4.1 cm diameter were installed for the neutron probe and groundwater observation (see the detail in Fig.3.3). The depths of the tubes are different depending on the depth of water table.

3.3.3 Planting and Crop Cultural Practices - A fertilizer rate 0, 187.5 and 375 kg/ha of a dosage 15-15-15 (N-P₂O₅-K₂O) corresponding to F1, F2 and F3-treatments were applied by broadcasting before making furrows. After completing the furrow, sweet corn seed, variety super sweet corn DMR#1, about 3-4 seeds were sown at spacing 75 cm between row and 25 cm

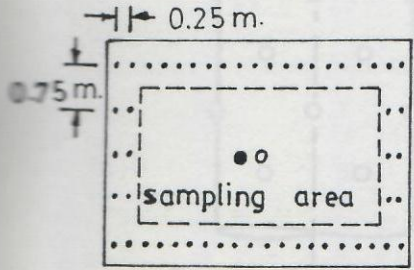
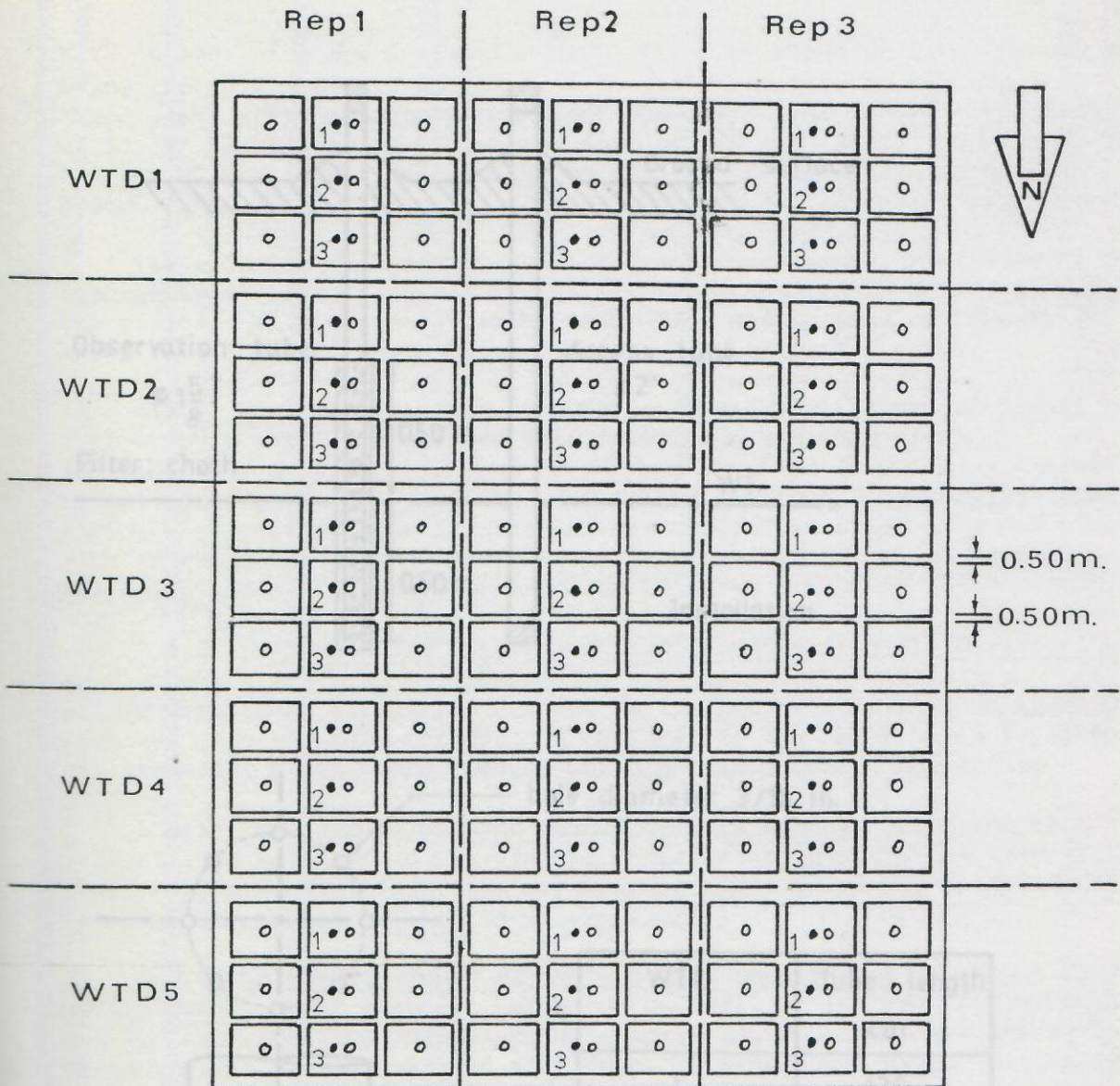

Plot detail

plot size 3.75 × 5.00 m²

sampling area 2.25 × 4.00 m²

population density in sampling area 48 plants/plot

○ access tube [neutron probe]

● observation tube [water table]

Fig 3.2 Access Layout Plan observation tube installation

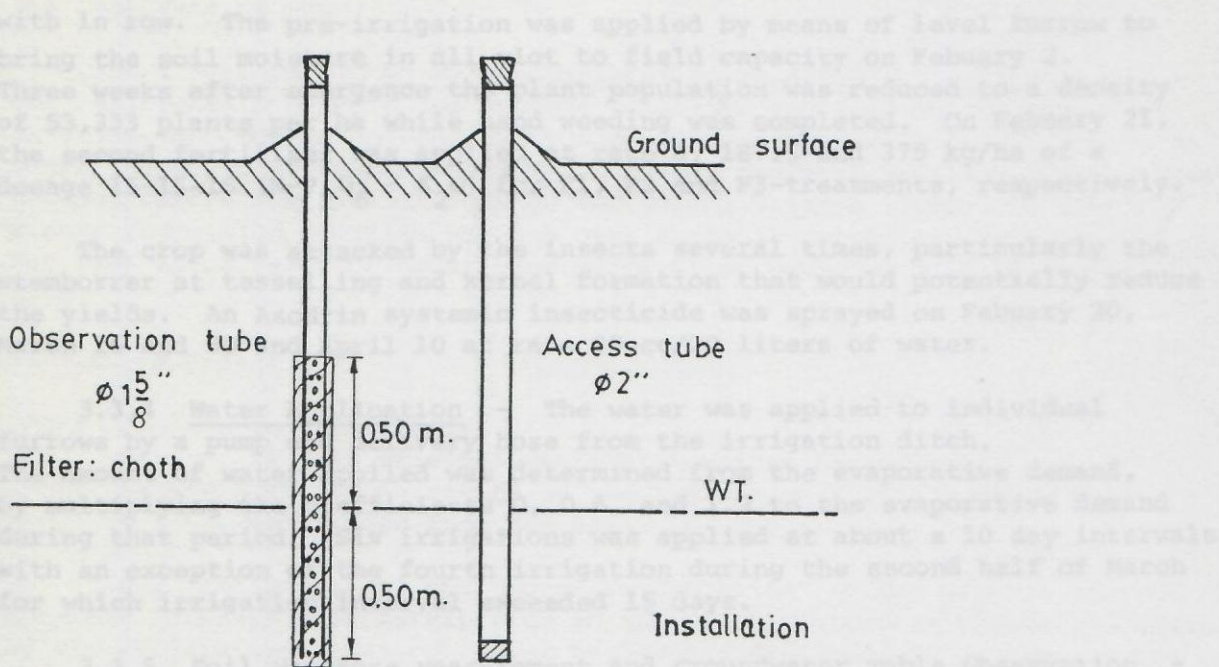

3.3.5 Soil moisture measurement and groundwater table observation - Neutron probe was used to measure the soil moisture on the field of one day before irrigation and two days after irrigation. Moisture readings were recorded for each 15 cm layer to the water table level for all treatment plots. One reading was also taken before harvesting.

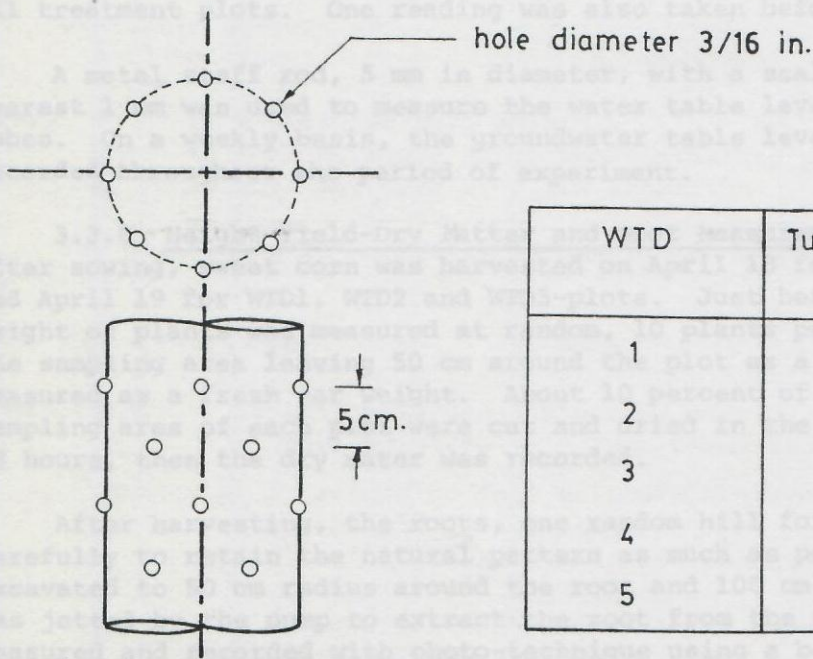

WTD	Tube length cm.
1	120
2	150
3	200
4	220
5	330

Detail of observation tube

Fig 3.3 Access tube and observation tube installation

with in row. The pre-irrigation was applied by means of level furrow to bring the soil moisture in all plot to field capacity on February 2. Three weeks after emergence the plant population was reduced to a density of 53,333 plants per ha while hand weeding was completed. On February 21, the second fertilizer was applied at rate 0, 187.5 and 375 kg/ha of a dosage 15-15-15 ($N-P_2O_5 - K_2O$) for F1, F2 and F3-treatments, respectively.

The crop was attacked by the insects several times, particularly the stemborrer at tasselling and kernel formation that would potentially reduce the yields. An Azodrin systemic insecticide was sprayed on February 20, March 16 and 30 and April 10 at rate 20 cc/20 liters of water.

3.3.4 Water Application - The water was applied to individual furrows by a pump and delivery hose from the irrigation ditch. The amount of water applied was determined from the evaporative demand, by multiplying the coefficients 0, 0.6, and 1.2 to the evaporative demand during that period. Six irrigations was applied at about a 10 day intervals with an exception of the fourth irrigation during the second half of March for which irrigation interval exceeded 15 days.

3.3.5 Soil Moisture Measurement and Groundwater Table Observation - Neutron probe was used to measure the soil moisture on the basis of one day before irrigation and two days after irrigation. Moisture readings were recorded for each 15 cm layer to the water table level for all treatment plots. One reading was also taken before harvesting.

A metal staff rod, 5 mm in diameter, with a scale graduated to a nearest 1 mm was used to measure the water table level in the observation tubes. On a weekly basis, the groundwater table level was observed and recorded throughout the period of experiment.

3.3.6 Height-Yield-Dry Matter and Root Measurement - About 75 days after sowing, sweet corn was harvested on April 18 for WTD3 and WTD4-plots and April 19 for WTD1, WTD2 and WTD5-plots. Just before harvesting, the height of plants was measured at random, 10 plants per plot. Yields in the sampling area leaving 50 cm around the plot as a buffer area were measured as a fresh ear weight. About 10 percent of the plants from sampling area of each plot were cut and dried in the oven at 80° c for 48 hours, then the dry mater was recorded.

After harvesting, the roots, one random hill for each plot were removed carefully to retain the natural pattern as much as possible. The soil was excavated to 50 cm radius around the root and 100 cm deep, then the water was jetted by the pump to extract the root from the soil. All roots were measured and recorded with photo-technique using a background reference scale. All roots were dried, then cut and weighed. The percent of the root distribution was calculated as follows:

$$\text{the percent of the root distribution for any layer} = \frac{100 \times \text{dry root weight for that layer}}{\text{total dry root weight}}$$

3.4 Analysis of Data

3.4.1 Determination of the Calibration Equation for Neutron probe -

The relationship between the average values of the soil moisture content in volume percentage and the neutron moisture readings in term of count ratio (measurement count/standard count) was analyzed by using the computer package called Statistical Package for Social Science (SPSS). A simple linear regression equation was the best explanation of this relationship for each 15 cm layer of soil. The calibration equation will be shown in form:

$$Y = aX + b$$

where Y is count ratio
X is soil moisture content in volume percentage
a and b are coefficients of the regression equation which were determined from the data.

3.4.2 Estimation of soil Moisture Depletion -

The data of neutron moisture readings were interpreted to the soil moisture in volume percentage by the calibration equation, layer by layer. The readings of layer below 90 cm from soil surface were interpreted by the equation for the layer 75-90 cm. The soil moisture in volume percentage was transformed to a more meaningful form, available percent of soil moisture which was defined as follows:

$$\text{available percent of soil moisture} = 100 \times \frac{(\theta - \text{PWP})}{(\text{FC} - \text{PWP})} \quad (3.2)$$

where θ is a measured soil moisture
PWP is soil moisture at permanent wilting point
FC is soil moisture at field capacity

The soil moisture depletion was estimated from the soil moisture data as follow:

$$\text{SMD}_{i,j} = |\theta_{i,j} - \theta_{i+1,j}| \times D \quad (3.1)$$

where SMD is soil moisture depletion, cm.
 θ is soil moisture in volume percentage
subscript i refers to soil moisture measurement at two days after the i^{th} irrigation
i+1 refers to soil moisture measurement at one day before the $(i+1)^{\text{th}}$ irrigation
j refers to j^{th} 15-cm layer of soil, and
D is depth of the soil layer, cm.

The soil moisture depletion calculated by Eq. (3.1) does not include the moisture depletion during the wetting period, two days after irrigation. Since during this period, the soil moisture is very high. The loss of water from the wet soil is at the potential rate which is assumed equal to the evaporation from class A pan. The SMD in Eq. (3.1) then was corrected as follows:

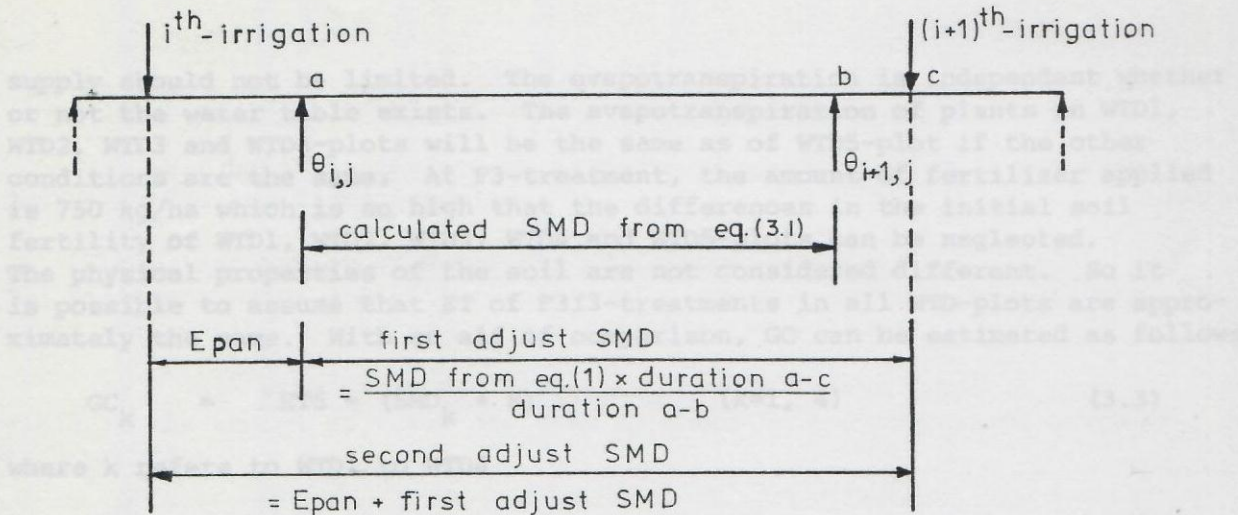

For the WTD5-plot in which the depth of water table is deeper than 250 cm from the soil surface, it is possible to assume no groundwater contribution to plants in that plot. Without an influence of groundwater, the soil moisture depletion in the effective root zone including rainfall if occurs, will represent the evapotranspiration of plants.

$$ET5_i = \sum_j SMD5_{i,j} + R_i \quad (3.2)$$

where $ET5$ is evapotranspiration in WTD5-plot, mm.
 $SMD5$ is soil moisture depletion in WTD5-plot, mm.
 R is effective rainfall, mm., and
 i and j are as previously defined.

The evapotranspiration in mm/day was calculated by dividing ET from Eq. (3.2) by the number of days between the period of soil moisture depletion.

3.4.3 Estimation of the Groundwater Contribution to Evapotranspiration of Crop. - As design, the plots on WTD1, WTD2, WTD3 and WTD4 are expected to have the groundwater contribution to plants. A groundwater contribution to evapotranspiration is defined as groundwater contributing to the root zone.

In view of the moisture balance, the term of groundwater contribution to evapotranspiration can be estimated as following equation:

$$GC = ET - SMD - R$$

where GC is groundwater contribution to and evapotranspiration

Unfortunately that the term of GC and ET can not be estimated separately. At the I3-treatment, the amount of water applied is as much as 1.2 times the evaporative demand. For this treatment the soil moisture

supply should not be limited. The evapotranspiration is independent whether or not the water table exists. The evapotranspiration of plants in WTD1, WTD2, WTD3 and WTD4-plots will be the same as of WTD5-plot if the other conditions are the same. At F3-treatment, the amount of fertilizer applied is 750 kg/ha which is so high that the differences in the initial soil fertility of WTD1, WTD2, WTD3, WTD4 and WTD5-plots can be neglected. The physical properties of the soil are not considered different. So it is possible to assume that ET of F3I3-treatments in all WTD-plots are approximately the same. With an aid of comparison, GC can be estimated as follows:

$$GC_k = ET5 - (SMD_k + R) \quad (k=1, 4) \quad (3.3)$$

where k refers to WTD1 to WTD4

3.4.4 Response of Yield VS Irrigation Water, Fertilizer and water Table Depth. The regression analysis was used to determine the relationship between crop yield, total amount of irrigation water applied total amount of fertilizer applied and the depth of water table by the following model:

$$Y = a_0 + a_1 X_1 + a_2 X_2 + a_3 X_3 + a_4 X_1 X_2 + a_5 X_1 X_3 + a_6 X_2 X_3 + a_7 X_1^2 + a_8 X_2^2 + a_9 X_3^2 \quad (3.4)$$

where Y is the fresh yield weight in kg/ha
 X_1 is the average water table depth in cm
 X_2 is the total amount of fertilizer applied in kg/ha
 X_3 is the total amount of irrigation water applied in mm.
 a_0, a_1, \dots, a_9 are the coefficients of the model.

Also the relationship fitted to the total amount of irrigation water and fertilizer applied with crop yield for WTD1, WTD2, WTD3, WTD4, WTD5 were done in similar way by the following model:

$$Y_i = b_0 + b_1 X_1 + b_2 X_2 + b_3 X_1 X_2 + b_4 X_1^2 + b_5 X_2^2 \quad (3.5)$$

where Y_i is the fresh yield weight in kg/ha in WTD-plot number i
 X_1 is the total amount of fertilizer applied in kg/ha
 X_2 is the total amount of irrigation water applied in mm.
 b_0, b_1, \dots, b_5 are the coefficients of the model.

3.4.5 Estimation of Water Application Efficiency (Ea). - The concept of water application efficiency was developed to focus attention upon the efficiency with which the water applied was being stored within the root zone where it could be used by plants. The concept is defined as

$$Ea = 100 \times \frac{Ws}{Wi} \quad (3.6)$$

where Ea is the water application efficiency in percent
 Ws is the water stored in root zone during irrigation
 Wi is the total amount of irrigation water applied

or

$$E_a = 100 \frac{\text{soil moisture deficiency}}{\text{total irrigation water applied}} \quad (3.7)$$

The soil moisture deficiency is defined as part of soil moisture depleted from the field capacity.

3.4.6 Estimation of Water Use Efficiency (MICHAEL, A.M., 1978). - Two different water use efficiencies which are the indices showing the water utilization by the crops were estimated as follows:

a) Crop Water Use Efficiency - It is the ratio of crop yield to the amount of water depleted by crops in the process of evapotranspiration

$$CWUE = \frac{Y}{ET} \quad (3.8)$$

where CWUE is the crop water use efficiency, kg/ha-cm

Y is the crop yield, kg/ha

ET is the evapotranspiration, cm, as estimated by soil moisture depletion.

b) Field Water Use Efficiency - It is the ratio of crop yield to the total amount of irrigation water used in the field

$$FWUE = \frac{Y}{W_i} \quad (3.9)$$

where FWUE is the field water use efficiency, kg/ha-cm

W_i is the total irrigation water used, cm.

IV PRESENTATION AND DISCUSSION OF RESULTS

4.1 Meteorological Conditions

The daily evaporation and rainfall observed at the experimental site were plotted in Fig. 4.1 to show the fluctuation of the evaporation from a class A pan throughout the growing period. Detailed rainfall and evaporation data are provided in Table A1 of the appendix. The evaporation tends to increase from the beginning of the growing season starting from February to reach a maximum around the end of March, then tends to decrease until the end of the growing season. The maximum evaporation is 10.63 mm on March 31 and the minimum is 2.72 on April 10. An average evaporation of the growing season is 6.86 mm/day. Two rains occurred, 4 mm on February 10 and 2 mm on April 16. This shows that the rain cannot be expected during dry season planting. Additional meteorological data recorded by Pilot Farm near Kalasin, 2 km away from the experimental area are wind velocity (between 1.60 - 5.91 km/day); mean daily relative humidity (between 54.5 - 73.5%); mean daily temperature (between 23.7 - 30.7 degree centigrade)

4.2 Soil Analysis Results

Soil properties are some of the most important factors in the agriculture and irrigation. Soil fertility has an influence on development and growth rate of plants, and a major effects on yields. Texture and structure of soil influence on the water holding capacity and moisture availability to plants. All the soil properties discussed here are necessary and useful in evaluation of the experimental results, furthermore it may be useful in the application of this study.

4.2.1 Soil Fertility - Three major elements required for plant growth namely nitrogen, potassium and phosphorus are good indices of the fertility status of soil. As shown in Table 4.1, the experimental area consists of soil of very poor productivity. The amount of organic matter and potassium in all WTD-plots are ranging from 0.60 to 0.80 % and 7.82 to 11.73 ppm, respectively, which are classified as low to very low. The phosphorus ranging from 15.4 to 44.4 ppm which is moderately high to high. Two of the three elements were lacking from this soil. The difference in the soil fertility between each WTD-plot is very little.

4.2.2 Physical Properties of Soil - Knowledge of soil and water relationship is valuable to all who are concerned with the improvement of irrigation practices, including the irrigators who desire to obtain the best use of water available for their farms. The physical properties of soil discussed here are needed for the better understanding of soil and water relationship.

Bulk Density and Particle Density - The bulk density of soils ranges from 1.38 to 1.79 gm/cc, as shown in Table 4.2. In exception of WTD1-plot, most of them exceed about 1.7 gm/cc indicating the hydraulic conductivity will be so low that the drainage may become difficult.

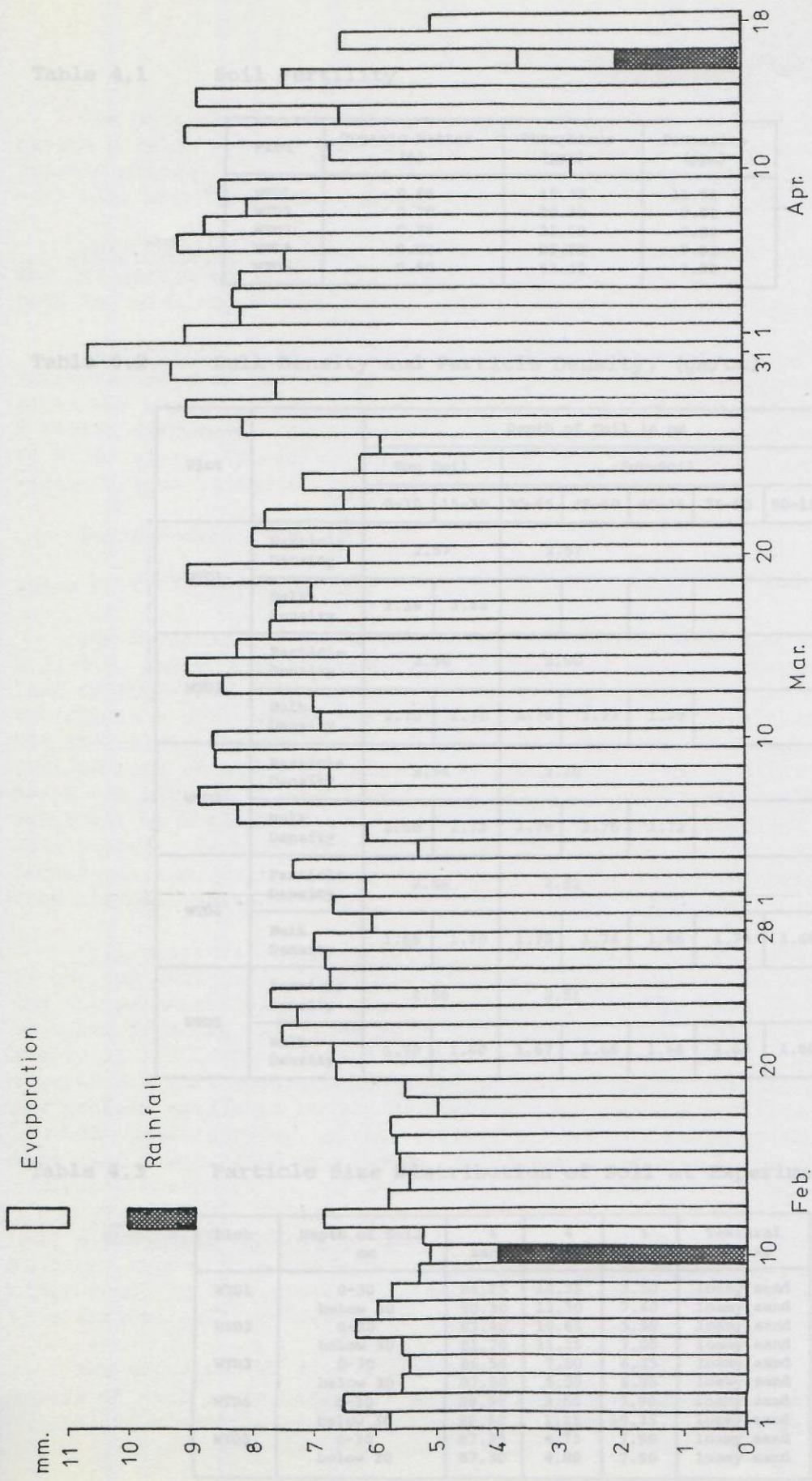

Fig 4.1 Daily Evaporation and Rainfall Observed at Experimental Site During The Entire Growing Season , Dry Season 1979

Table 4.1 Soil Fertility

Plot	Organic Matter (%)	Phosphorus (ppm)	Potassium (ppm)
WTD1	0.66	15.40	11.73
WTD2	0.78	30.30	7.82
WTD3	0.76	21.60	7.82
WTD4	0.80	22.70	7.82
WTD5	0.60	44.40	7.82

Table 4.2 Bulk Density and Particle Density, (gm/cc)

Plot		Depth of Soil in cm						
		Top Soil		Sub-Soil				
		0-15	15-30	30-45	45-60	60-75	75-90	90-105
WTD1	Particle Density	2.57		2.57				
	Bulk Density	1.38	1.44					
WTD2	Particle Density	2.56		2.60				
	Bulk Density	1.70	1.75	1.76	1.77	1.79		
WTD3	Particle Density	2.54		2.16				
	Bulk Density	1.68	1.73	1.76	1.76	1.72		
WTD4	Particle Density	2.56		2.52				
	Bulk Density	1.65	1.70	1.75	1.74	1.65	1.74	1.68
WTD5	Particle Density	2.56		2.51				
	Bulk Density	1.70	1.60	1.67	1.66	1.66	1.68	1.68

Table 4.3 Particle Size Distribution of Soil at Experimental Site

Plot	Depth of Soil cm	% sand	% clay	% silt	Textural class
WTD1	0-30	84.15	12.35	3.50	loamy sand
	below 30	80.30	12.30	7.40	loamy sand
WTD2	0-30	83.40	10.65	5.95	loamy sand
	below 30	81.70	11.25	7.05	loamy sand
WTD3	0-30	86.55	7.20	6.25	loamy sand
	below 30	87.50	5.55	6.95	loamy sand
WTD4	0-30	88.50	3.60	7.90	loamy sand
	below 30	88.50	1.15	10.35	loamy sand
WTD5	0-30	87.35	4.75	7.90	loamy sand
	below 30	87.30	4.80	7.90	loamy sand

The particle density of soils ranges from 2.16 to 2.60 gm/cc, most having a value greater than 2.5 gm/cc indicating a low percentage of organic matter in both top soil and subsoil. The particle density of soil with high organic matter content usually falls between 1.50 to 2.00 gm/cc.

Soil Texture - Particle size distribution as shown in Table 4.3, the percentage of sand, soil and clay are about 86, 7 and 7 respectively. Both top soil and subsoil of all WTD-plots are classified as Loamy Sand.

Infiltration Rate - The infiltration rate curves, which show the characteristic of soil to transmit the water into the soil, of all WTD-plots are quite similar with exception of WTD1 and WTD5-plots which are a little different. Infiltration rate curves are presented in Fig. A1(1) to A1(5) of the appendix. By definition, the basic intake rate is an instantaneous intake at the time when $\Delta I = 0.1I$ or

$$\text{Basic intake rate} = kT^n$$

where $T = |600n| \text{ min}$

The basic intake rates of soil in WTD1, WTD2, WTD3 and WTD4-plots are 1.1, 6.3, 7.0, and 8.7 mm/hr respectively which are very low comparing with that of WTD5-plot, 26.6 mm/hr. It can be explained that the underlying subsoil is a semi-impervious layer having a very low capability to transmit the water. Secondly, the soils have a property to reduce the infiltration rate at a certain time after applying the water since the macropores are blocked by the very fine particles. First explanation is in agreement with the soil survey reported by Kalasin Pilot Farm project. Soil porosity is negatively correlated to the bulk density as the depth increased, indicating a poor structured (compacted) layer not very far down from the soil surface.

Soil Moisture Characteristic Curve - The field capacity at 1/3 atm., of the top soil and subsoil are 15.31 and 16.30 percent on dry weight basis and the permanent wilting point are 3.10 and 1.49 percent, respectively, as taken from Fig. A2(1) to A2(2) of appendix. The available moisture are 12.21 and 14.81 per cent on dry weight for the top soil and subsoil. However the soil moisture content near the permanent wilting point is not readily available to plants, so the term readily available moisture has been used to refer to that portion of the available moisture that is most easily extracted by plants. It is approximately 75 percent of the available moisture.

4.2.3 Salt Problem in the Soil - In shallow water table area, the soil moisture supply from the water table may cause a high crop yield, on the other hand, in area where salts occur, the high water table may be followed by a serious salt problem and a reduction in yield.

The experimental area consists of lands with high water table. The hazard of salt accumulation is also of interest. The soil reaction (pH), electrical conductivity and exchangeable sodium percentage as shown in

Table 4.4 are the good indices of salt conditions. The EC of soils is less than 4,000 micromhos/cm at 25^o degree centigrade and the ESP is less than 15 which show no salinity and alkalinity problems in this area. The soil pH is about 6.0, showing a little acidity in the soil.

Table 4.4 Comparison of pH, EC and ESP of Soil, Before Planting and After Harvesting.

Plot	Soil Properties	Before Planting	After Harvesting
WTD1	pH	6.00	6.20
	EC (micromhos/cm. at 25 ^o C)	102.70	138.40
	Na (meg/100gm oven dry soil)	0.21	0.22
	CEC(meg/100gm oven dry soil)	2.10	2.20
	ESP	10.00	10.00
WTD2	pH	5.80	5.50
	EC	65.40	22.50
	Na	0.15	0.21
	CEC	2.85	1.95
	ESP	5.26	10.77
WTD3	pH	5.40	5.60
	EC	69.70	89.20
	Na	0.12	0.15
	CEC	2.55	2.60
	ESP	4.71	5.77
WTD4	pH	5.90	5.55
	EC	70.00	116.00
	Na	0.09	0.26
	CEC	2.80	2.50
	ESP	3.21	10.40
WTD5	pH	5.90	5.60
	EC	43.10	62.30
	Na	0.17	0.19
	CEC	2.30	2.23
	ESP	7.29	8.52

Irrigation water and groundwater were also tested, the data were shown in Table 4.5. The pH of irrigation water is about 6.5 which is in normal range, while the pH of groundwater ranges from 6.1 to 7.6 indicating a little acidity in WTD1 and WTD4-plots. The EC of both irrigation water and groundwater is less than 750 micromhos/cm at 25^oC. No salinity problems are to be expected from the water.

The differences between these properties of soil and water samples taken before planting and after harvesting cannot be evaluated. However, it shows that the farmers can use the groundwater in this area as a sub-surface water supply to plants without salt problem.

Table 4.5 pH and EC of Irrigation Water and Groundwater

Source		Before Planting	After Harvesting
WTD1	pH	6.2	6.4
	EC (micromhos/cm at 25°C)	619.0	461.0
WTD2	pH	7.6	6.2
	EC	360.0	423.0
WTD3	pH	7.1	6.3
	EC	386.0	381.0
WTD4	pH	6.1	6.4
	EC	312.0	318.0
Irrigation water	pH	6.6	6.4
	EC	139.1	141.9

4.3 Groundwater Fluctuation

The groundwater level was observed along the lines parallel to the unlined irrigation ditch, three observation tubes for each line and three lines for each WTD-plot. The entire record of weekly readings is shown in Table A2 of the appendix. Mean of each line (3 observed values) are plotted in Fig. 4.2 to show the fluctuation of the groundwater table during the period of the experiment. Small arrows below the groundwater fluctuation curves indicate the irrigation timing in that WTD-plot. The curves show that the groundwater level of all WTD-plot fluctuates from time to time. The fluctuation depends on the irrigation application and water supplied to the ditch, particularly in WTD-plot closer to the ditch. The water table tends to drop from the beginning to the end of the experimental period. The difference of water table depth between the beginning and the end of the experimental period is as much as 40 cm, particularly in WTD1-plot. In addition, the difference of water table depth within WTD-plot was found to be about 10 cm for WTD1-plot depending on the distance from the ditch, but the other plots the differences were not significant.

4.4 Neutron Moisture Meter Calibration

Regression analysis shows that a soil moisture content in volume percentage has a straight line relationship with a meter readings in term of count ratio. The calibration equations for each 15 cm layer are shown in Table 4.6, all are statistically significant at 5% level by F-test. The adequacy of the fitted equations, coefficients of determination (R^2) are over 0.80, which are quite satisfactory. The calibration curves as shown in Fig. 4.3 indicate the similar pattern in all curves with exception of the curve for the surface layer. The difference in the calibration equation for the surface layer and for the lower layer is due to the difference in the geometrical configuration of soil surrounding the probe.

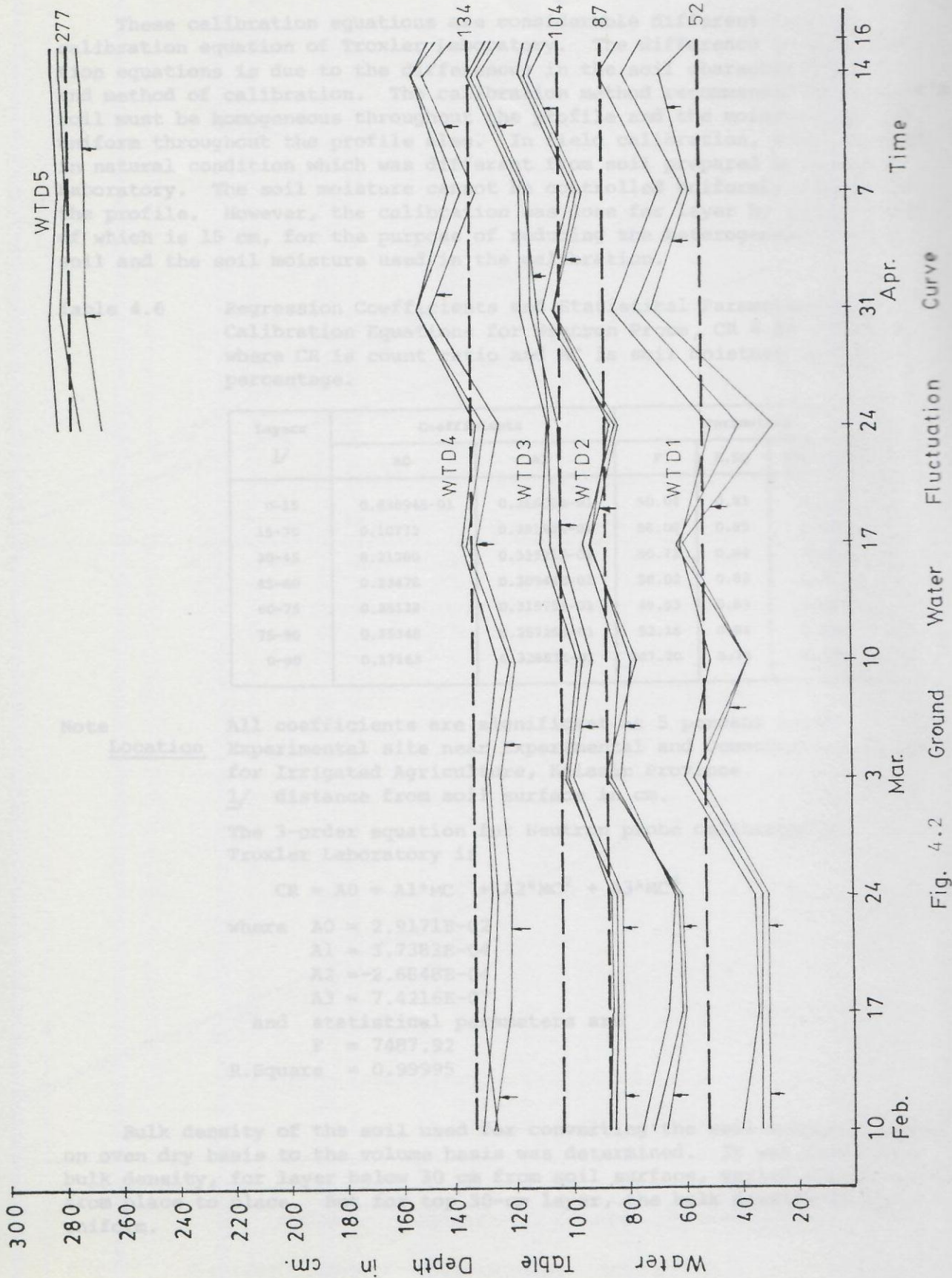

Fig. 4.2

These calibration equations are considerable different from the calibration equation of Troxler Laboratory. The difference in calibration equations is due to the differences in the soil characteristics and method of calibration. The calibration method recommended by Troxler's, soil must be homogeneous throughout the profile and the moisture must be uniform throughout the profile also. In field calibration, soil was kept in natural condition which was different from soil prepared by Troxler Laboratory. The soil moisture cannot be controlled uniformly throughout the profile. However, the calibration was done for layer by layer, each of which is 15 cm, for the purpose of reducing the heterogeneity in the soil and the soil moisture used in the calibration.

Table 4.6 Regression Coefficients and Statistical Parameters of Calibration Equations for Neutron Probe, $CR = A_0 + A_1 \cdot MC$, where CR is count ratio and MC is soil moisture in volume percentage.

Layers l/	Coefficients		Parameters		
	A0	A1	F	R.SQ	STD. ERROR
0-15	0.63894E-01	0.26606E-01	50.04	0.83	0.0825
15-30	0.10772	0.38192E-01	58.08	0.85	0.1007
30-45	0.21280	0.33521E-01	50.72	0.84	0.1065
45-60	0.23476	0.30944E-01	50.02	0.83	0.1110
60-75	0.25138	0.31575E-01	49.53	0.83	0.1206
75-90	0.35348	0.25726E-01	52.16	0.84	0.1111
0-90	0.17163	0.32663E-01	247.20	0.78	0.1364

Note
Location All coefficients are significant at 5 percent level
 Experimental site near Experimental and Demonstration Farm
 for Irrigated Agriculture, Kalasin Province.
 l/ distance from soil surface in cm.

The 3-order equation for Neutron probe calibrated by Troxler Laboratory is

$$CR = A_0 + A_1 \cdot MC + A_2 \cdot MC^2 + A_3 \cdot MC^3$$

where $A_0 = 2.9171E-02$
 $A_1 = 3.7383E-04$
 $A_2 = -2.6848E-04$
 $A_3 = 7.4216E-07$

and statistical parameters are

$$F = 7487.92$$

$$R.Square = 0.99995$$

Bulk density of the soil used for converting the soil moisture content on oven dry basis to the volume basis was determined. It was found that bulk density, for layer below 30 cm from soil surface, varied significantly from place to place. But for top 30-cm layer, the bulk density is quite uniform.

Fig. 4.6 Neutron Moisture Calibration Curve

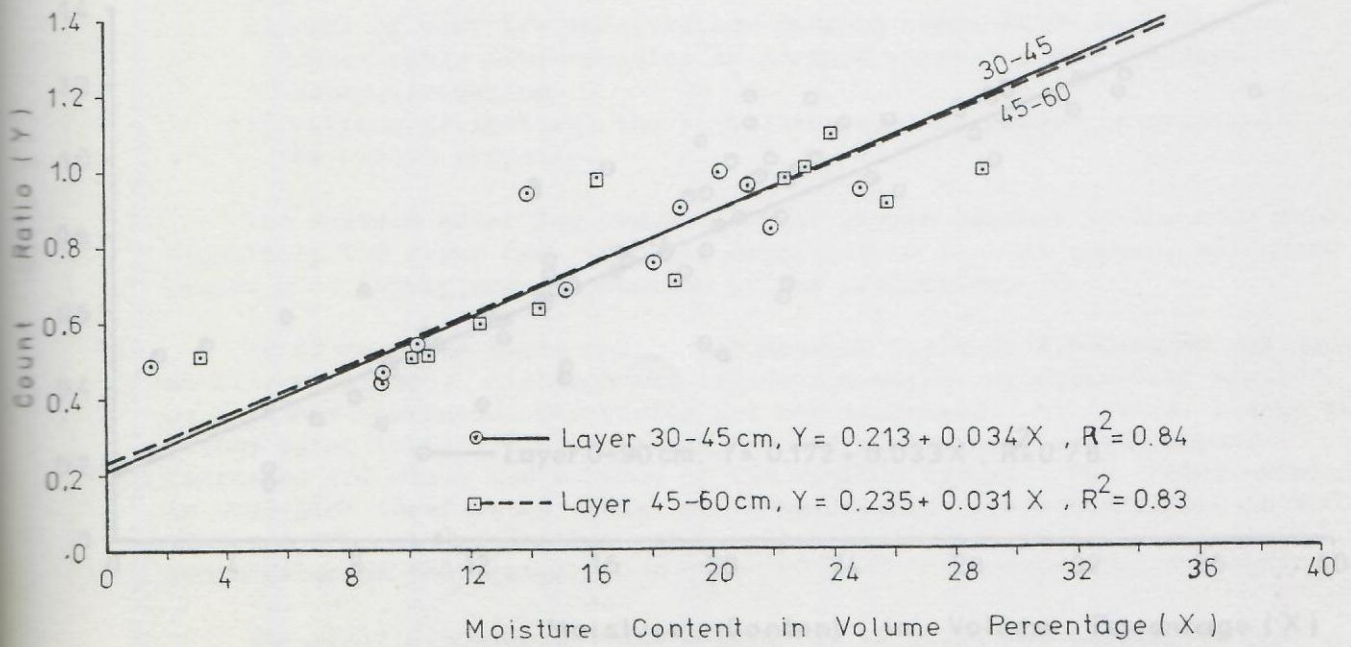
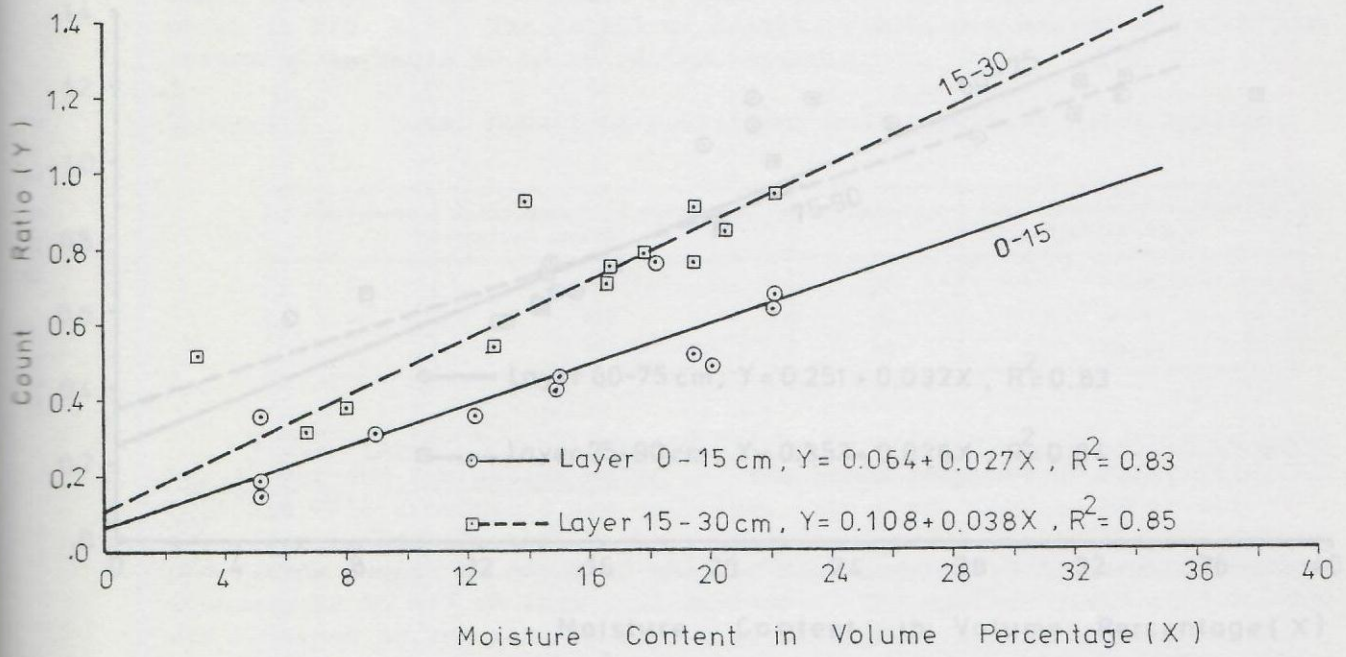

Fig 4.3 Neutron Moisture Calibration Curve

4.5 Inputs to Crop and Production Function

The experimental results show that with this input combination of irrigation water and fertilizer as shown in Table 4.7, the response of sweet corn grown in the plots of different water table were obtained as shown in Fig. 4.4. The detail of height, yield, dry matter and root are presented in Table A3 to A6 of the Appendix.

Table 4.7 Total amount of Fertilizer and Irrigation water Applied.

Treatments	Total amount of Fertilizer applied (kg/ha)	Total amount of Irrigation water applied (cm)
11	21	0.5
12	12	21.5
13	12	21.5

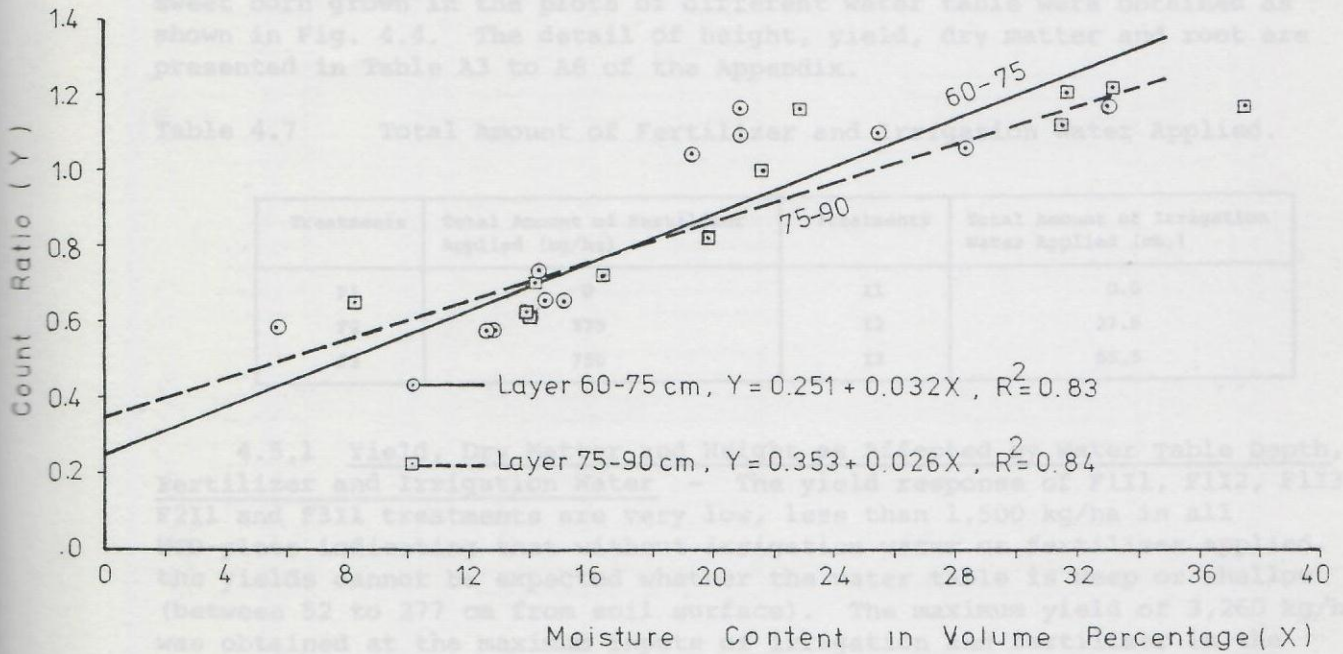

4.5.1 Effect of Water Table Depth, Fertilizer and Irrigation water on the yield of sweet corn. The yield of sweet corn in the plots of different water table depth is a little lower, 3,200 kg/ha, at the same inputs. At 52-cm water table depth, the yield of less than 500 kg/ha were obtained in all treatments of irrigation and fertilizer. Very low or almost no yields in WTD1-plot are considered to be caused by the following reasons:

- i) soil of very low infiltration rate in combination with large water table depth results in surface water log for many days after irrigation
- ii) without irrigation, the fertilizer cannot be utilized by plants properly

The surface water log by causing the oxygen content in the root zone, especially for sweet corn which is sensitive to lack of oxygen, subsequently causes root injury and reduction of crop production.

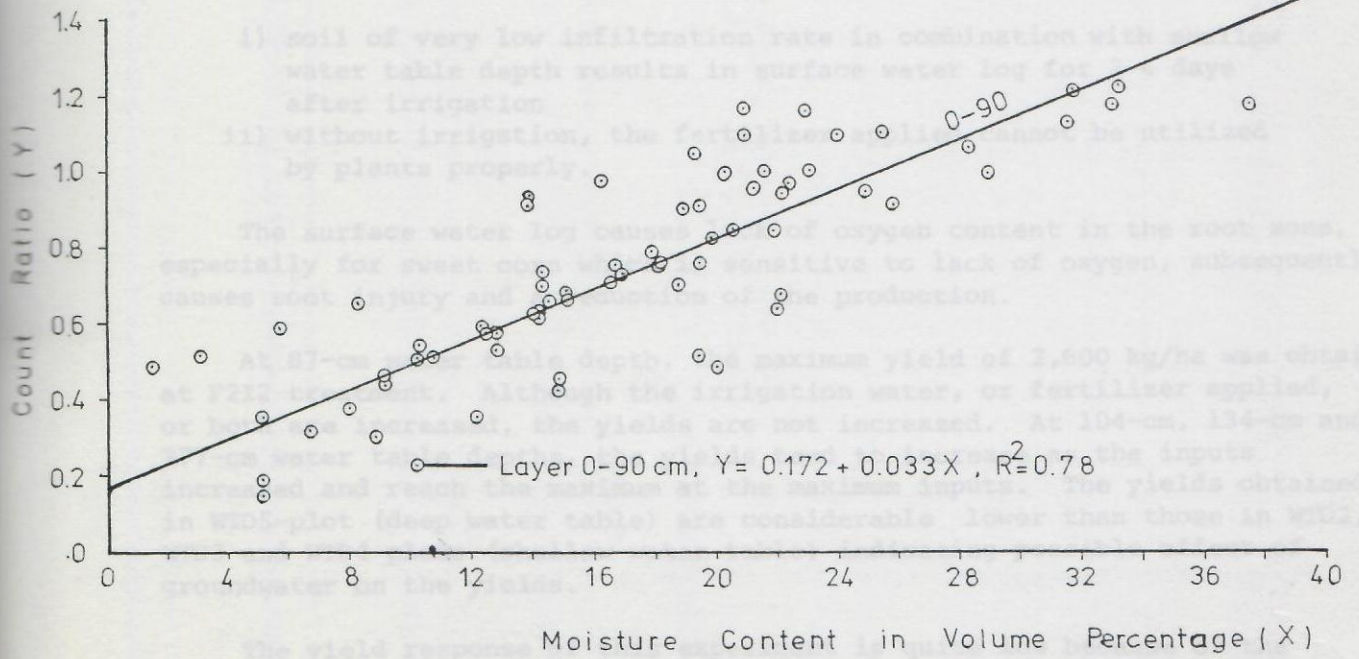

At 87-cm water table depth, the maximum yield of 2,600 kg/ha was obtained at 21 kg/ha. Although the irrigation water, or fertilizer applied, or both were increased, the yields are not increased. At 104-cm, 134-cm and 154-cm water table depth, the yields obtained at the same inputs increased and reach the maximum at the same inputs. The yields obtained in WTD2-plot (deep water table) are considerable lower than those in WTD1, or WTD3-plot.

Fig.4.3(cont) Neutron Moisture Calibration Curve

4.5 Inputs to Crop and Production Function

The experimental results show that with the input combination of irrigation water and fertilizer as shown in Table 4.7, the response of sweet corn grown in the plots of different water table were obtained as shown in Fig. 4.4. The detail of height, yield, dry matter and root are presented in Table A3 to A6 of the Appendix.

Table 4.7 Total Amount of Fertilizer and Irrigation Water Applied.

Treatments	Total Amount of Fertilizer Applied (kg/ha)	Treatments	Total Amount of Irrigation Water Applied (cm.)
F1	0	I1	0.0
F2	375	I2	27.8
F3	750	I3	55.5

4.5.1 Yield, Dry Matter and Height as Affected by Water Table Depth, Fertilizer and Irrigation Water - The yield response of F1I1, F1I2, F1I3, F2I1 and F3I1 treatments are very low, less than 1,500 kg/ha in all WTD-plots indicating that without irrigation water or fertilizer applied, the yields cannot be expected whether the water table is deep or shallow (between 52 to 277 cm from soil surface). The maximum yield of 3,260 kg/ha was obtained at the maximum inputs of irrigation and fertilizer in the plot of 104-cm water table depth while the maximum yield of 134-cm water table depth is a little lower, 3,200 kg/ha, at the same inputs. At 52-cm water table depth, the yield of less than 500 kg/ha were obtained in all treatments of irrigation and fertilizer. Very low or almost no yields in WTD1-plot are considered to be caused by the following reasons:

- i) soil of very low infiltration rate in combination with shallow water table depth results in surface water log for 2-4 days after irrigation
- ii) without irrigation, the fertilizer applied cannot be utilized by plants properly.

The surface water log causes lack of oxygen content in the root zone, especially for sweet corn which is sensitive to lack of oxygen, subsequently causes root injury and a reduction of the production.

At 87-cm water table depth, the maximum yield of 2,600 kg/ha was obtained at F2I2 treatment. Although the irrigation water, or fertilizer applied, or both are increased, the yields are not increased. At 104-cm, 134-cm and 277-cm water table depths, the yields tend to increase as the inputs increased and reach the maximum at the maximum inputs. The yields obtained in WTD5-plot (deep water table) are considerable lower than those in WTD2, WTD3 and WTD4-plots (shallow water table) indicating possible effect of groundwater on the yields.

The yield response of this experiment is quite low because of the following reasons:

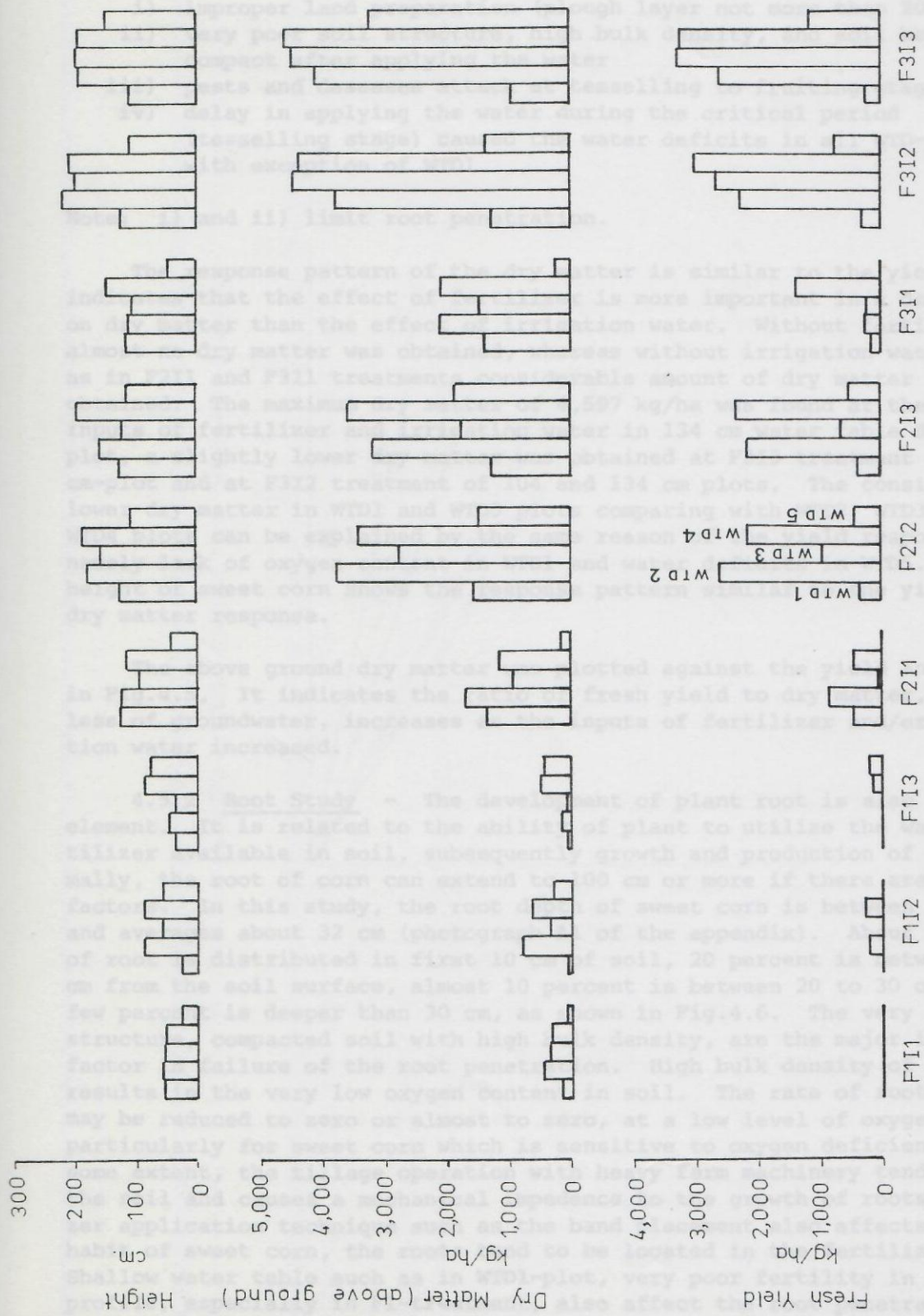

Fig 4.4 Bar Chart Showing Yield, Dry Matter and Height Response to Water Table Depth, Fertilizer and Irrigation Water Applied

- i) improper land preparation (plough layer not more than 20 cm)
- ii) very poor soil structure, high bulk density, and soil become compact after applying the water
- iii) pests and diseases attack at tesselling to fruiting stage
- iv) delay in applying the water during the critical period (tesselling stage) caused the water deficits in all WTD-plots with exception of WTD1

Note: i) and ii) limit root penetration.

The response pattern of the dry matter is similar to the yield, which indicates that the effect of fertilizer is more important in a depression on dry matter than the effect of irrigation water. Without fertilizer, almost no dry matter was obtained, whereas without irrigation water such as in F2I1 and F3I1 treatments considerable amount of dry matter was still obtained. The maximum dry matter of 4,597 kg/ha was found at the maximum inputs of fertilizer and irrigation water in 134 cm water table depth plot, a slightly lower dry matter was obtained at F3I3 treatment of 104 cm-plot and at F3I2 treatment of 104 and 134 cm plots. The considerable lower dry matter in WTD1 and WTD5 plots comparing with WTD2, WTD3 and WTD4 plots can be explained by the same reason of the yield response, namely lack of oxygen content in WTD1 and water deficits in WTD5. The height of sweet corn shows the response pattern similar to the yield and dry matter response.

The above ground dry matter was plotted against the yield and shown in Fig.4.5. It indicates the ratio of fresh yield to dry matter, regardless of groundwater, increases as the inputs of fertilizer and/or irrigation water increased.

4.5.2 Root Study - The development of plant root is also an important element. It is related to the ability of plant to utilize the water and fertilizer available in soil, subsequently growth and production of crop. Normally, the root of corn can extend to 100 cm or more if there are no limiting factors. In this study, the root depth of sweet corn is between 20 to 45 cm and averages about 32 cm (photograph A1 of the appendix). About 70 percent of root is distributed in first 10 cm of soil, 20 percent is between 10 to 20 cm from the soil surface, almost 10 percent is between 20 to 30 cm, only a few percent is deeper than 30 cm, as shown in Fig.4.6. The very poor soil structure, compacted soil with high bulk density, are the major important factor in failure of the root penetration. High bulk density of the soil results in the very low oxygen content in soil. The rate of root growth may be reduced to zero or almost to zero, at a low level of oxygen content, particularly for sweet corn which is sensitive to oxygen deficiency. To some extent, the tillage operation with heavy farm machinery tends to compact the soil and causes a mechanical impedece to the growth of roots. Fertilizer application technique such as the band placement also affects the rooting habit of sweet corn, the roots tend to be located in the fertilized area. Shallow water table such as in WTD1-plot, very poor fertility in subsoil profile, especially in F1-treatment, also affect the root penetration.

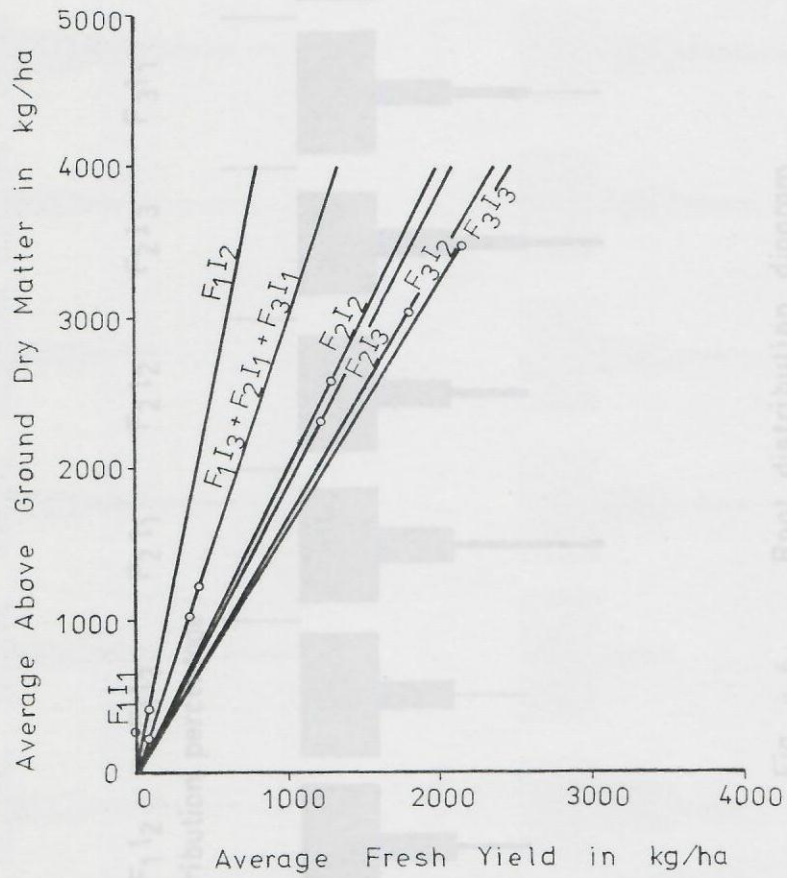

Fig 4.5 Dry Matter VS. Fresh Yield for All Combination Treatments of Fertilizer and Irrigation Water

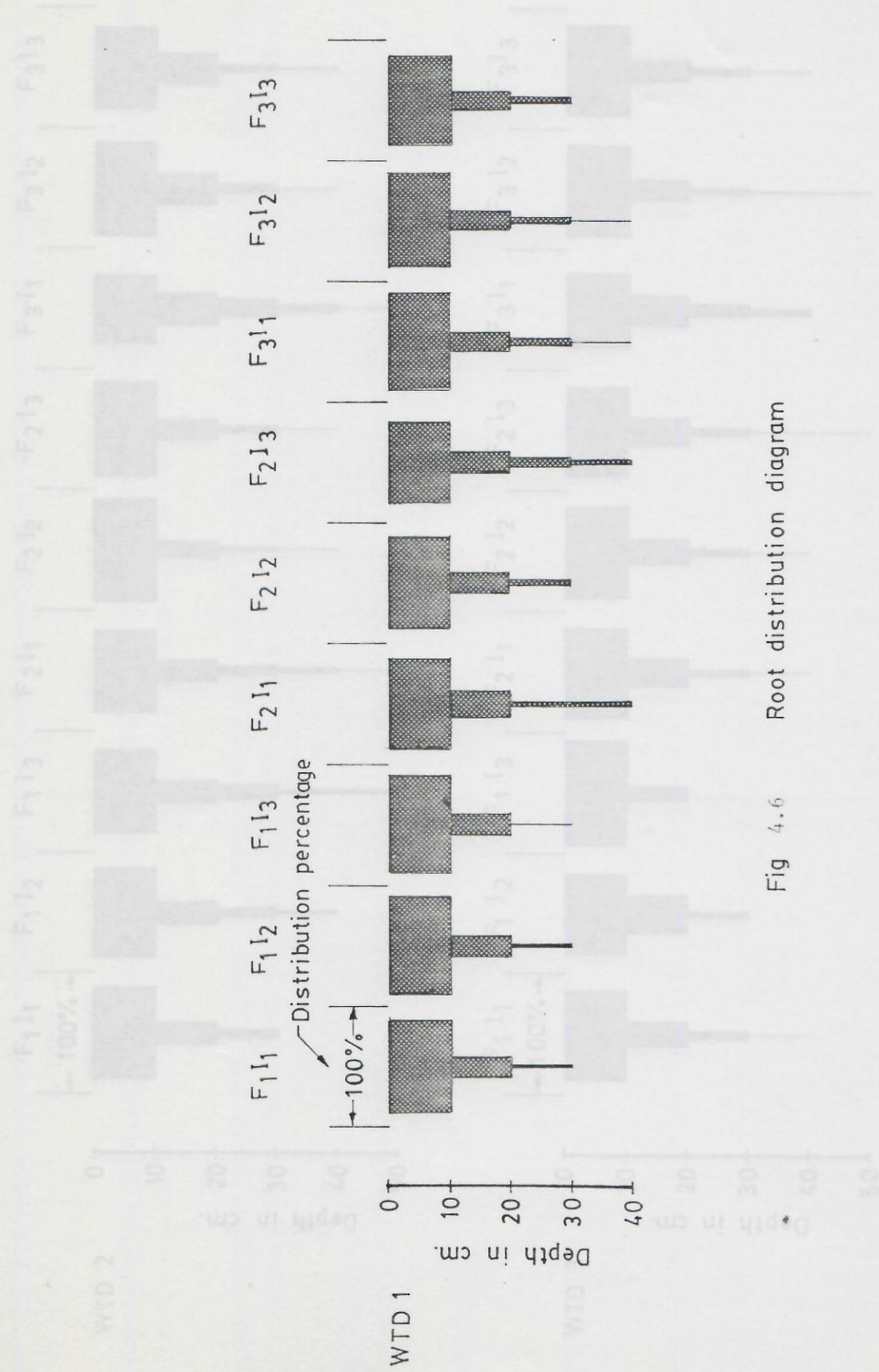

Fig 4.6 Root distribution diagram

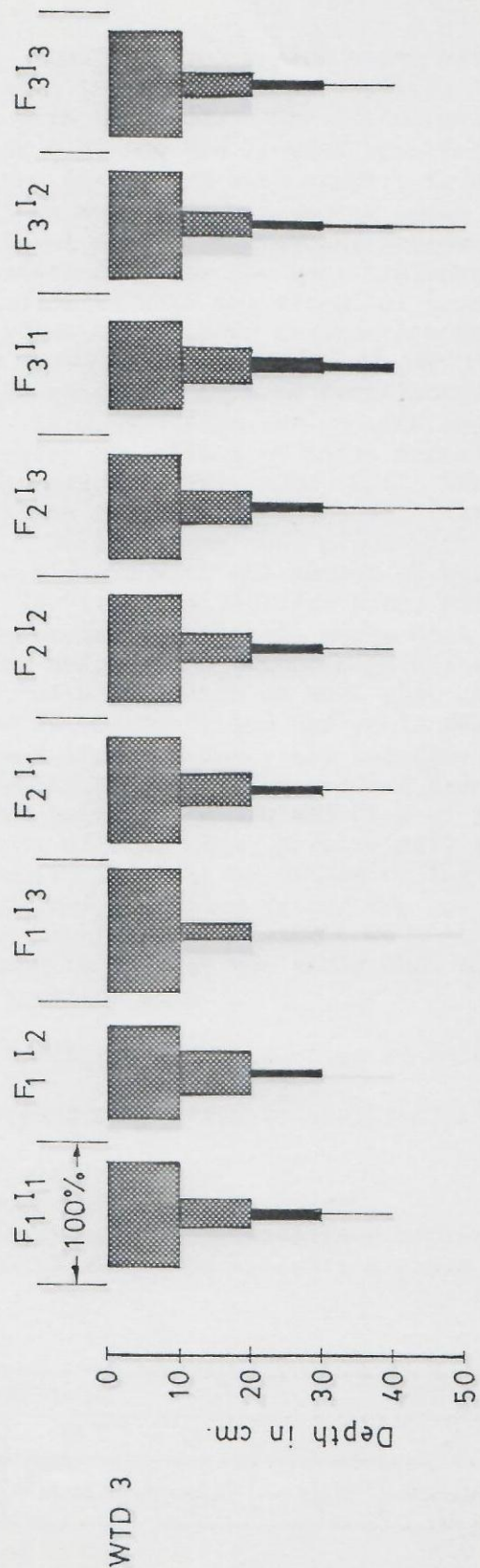
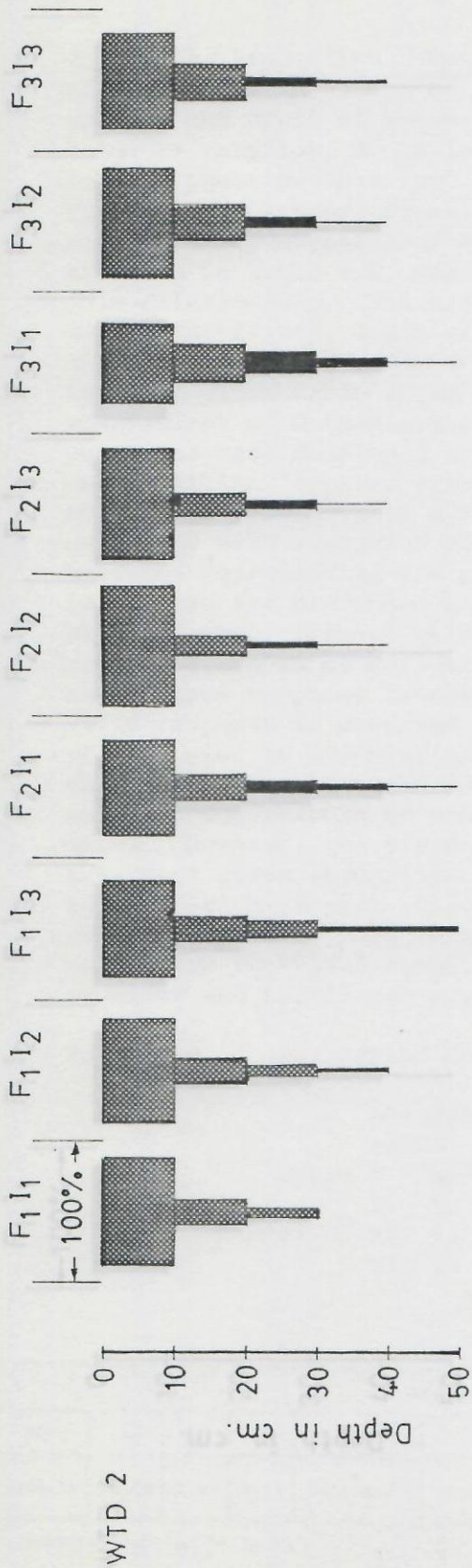

Fig 4.6(cont.) Root distribution diagram

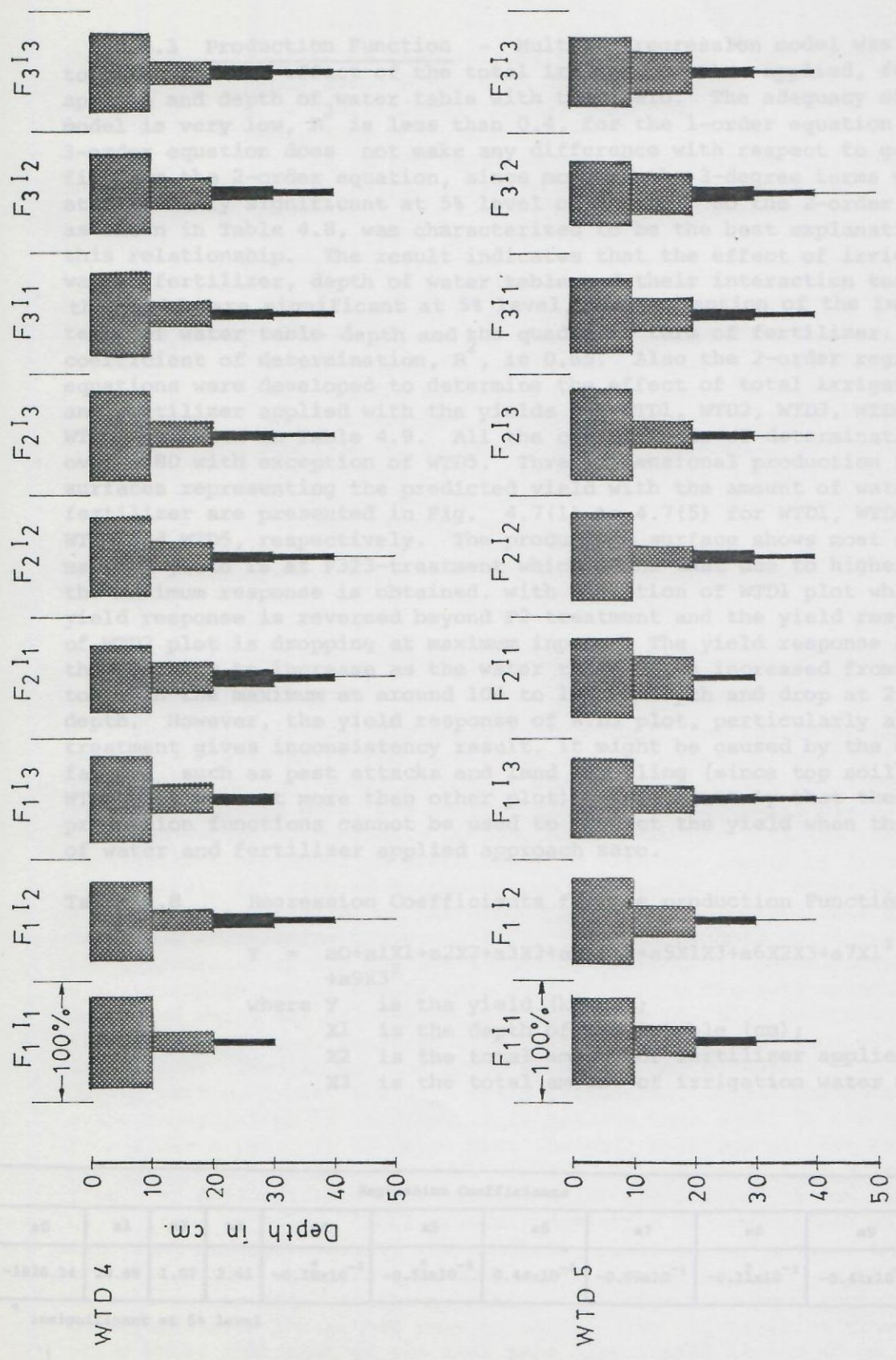

Fig 4.6(cont.) Root distribution diagram

4.5.3 Production Function - Multiple regression model was developed to determine the effect of the total irrigation water applied, fertilizer applied and depth of water table with the yield. The adequacy of fitted model is very low, R^2 is less than 0.4, for the 1-order equation and the 3-order equation does not make any difference with respect to goodness of fit from the 2-order equation, since most of the 3-degree terms were not statistically significant at 5% level of F-test. So the 2-order equation, as shown in Table 4.8, was characterized to be the best explanation of this relationship. The result indicates that the effect of irrigation water, fertilizer, depth of water table and their interaction term with the yields are significant at 5% level, with exception of the interaction terms of water table depth and the quadratic term of fertilizer. The coefficient of determination, R^2 , is 0.65. Also the 2-order regression equations were developed to determine the effect of total irrigation water and fertilizer applied with the yields for WTD1, WTD2, WTD3, WTD4 and WTD5, as shown in Table 4.9. All the coefficients of determination are over 0.80 with exception of WTD5. Three dimensional production function surfaces representing the predicted yield with the amount of water and fertilizer are presented in Fig. 4.7(1) to 4.7(5) for WTD1, WTD2, WTD3, WTD4 and WTD5, respectively. The production surface shows most of the maximum yield is at F3I3-treatment which means that due to higher input the maximum response is obtained, with exception of WTD1 plot which the yield response is reversed beyond F2 treatment and the yield response of WTD2 plot is dropping at maximum inputs. The yield response shows the tendency to increase as the water table depth increased from 52 cm to reach the maximum at around 104 to 134 cm depth and drop at 277 cm depth. However, the yield response of WTD3 plot, particularly at F2 treatment gives inconsistency result, it might be caused by the other factors such as pest attacks and land levelling (since top soil of WTD3 plot was cut more than other plot). Unfortunately that these production functions cannot be used to predict the yield when the amount of water and fertilizer applied approach zero.

Table 4.8 Regression Coefficients for the production Function:

$$Y = a_0 + a_1X_1 + a_2X_2 + a_3X_3 + a_4X_1X_2 + a_5X_1X_3 + a_6X_2X_3 + a_7X_1^2 + a_8X_2^2 + a_9X_3^2$$

- where Y is the yield (kg/ha);
 X1 is the depth of water table (cm);
 X2 is the total amount of fertilizer applied (kg/ha);
 X3 is the total amount of irrigation water applied (mm).

Regression Coefficients										Parameters	
a0	a1	a2	a3	a4	a5	a6	a7	a8	a9	F	R.SQ
-1826.34	28.49	1.67	2.41	-0.10*10 ⁻²	-0.53*10 ⁻³	0.44*10 ⁻²	-0.85*10 ⁻¹	-0.11*10 ⁻²	-0.41*10 ⁻²	24.31	0.65

* insignificant at 5% level

Table 4.9 Regression Coefficients for the Production Function of WTD1, WTD2, WTD3, WTD4 and WTD5;

$$Y = b_0 + b_1X_1 + b_2X_2 + b_3X_1X_2 + b_4X_1^2 + b_5X_2^2$$

where Y is the yield (kg/ha);

X₁ is the total amount of fertilizer applied (kg/ha);

X₂ is the total amount of irrigation water applied (mm)

Plot	Regression Coefficients						Parameters	
	b ₀	b ₁	b ₂	b ₃	b ₄	b ₅	F	R.SQ
WTD1	4.78	1.79	0.11*	0.18x10 ⁻³	-0.20x10 ⁻²	-0.30x10 ⁻³ *	25.05	0.88
WTD2	-253.67	6.19	5.12	0.52x10 ⁻²	-0.72x10 ⁻²	-0.86x10 ⁻²	17.46	0.83
WTD3	-16.62	-1.89*	3.02*	0.70x10 ⁻²	0.35x10 ⁻²	-0.62x10 ⁻²	31.80	0.88
WTD4	-269.48	3.65	4.69	0.39x10 ⁻²	-0.21x10 ⁻² *	-0.68x10 ⁻² *	16.93	0.80
WTD5	2.60	-0.31*	0.46*	0.29x10 ⁻²	0.49x10 ⁻³ *	-0.50x10 ⁻³ *	5.57	0.60

* insignificant at 5% level

4.6 Evapotranspiration and Groundwater Contribution to Evapotranspiration of Sweet Corn

The soil moisture data measured throughout the period of the experiment were presented in the form of available percent of soil moisture. The portion of soil moisture higher than field capacity and lower than permanent wilting point was omitted since it is not available by plants. The mean values of available percent of soil moisture of the three replications are shown in graphical form with the inputs of irrigation and rainfall for each of 9-combination treatments and 5 water table depths in Fig. A3(1) to A3(15) of the appendix (raw data is available at Water Resources Engineering Division, AIT). By mean of soil moisture study, the evapotranspiration and the amount of groundwater contributing to evapotranspiration of plants were estimated from the soil moisture depletion which was calculated by subtracting the soil moisture, within effective root zone, measured before (i+1)th irrigation from after ith irrigation. Then it was corrected by adding the potential evapotranspiration during wetting cycle, two days after irrigation. Since the potential evapotranspiration is unknown, it is assumed that equal to the evaporation from class A pan. It is noted that the soil moisture at just after pre-irrigation was not measured. In the estimation of soil moisture depletion, the soil moisture content just after pre-irrigation was assumed to be at field capacity. Soil moisture depletion was calculated with two different methods. First, the moisture depletion was assumed that occurred within the effective root zone, and the results are shown in Table A⁷(1) to A⁷(5) of the appendix. The effective root zone was considered from the actual rooting depth. The information from root study shows that most of the root zone distributed in top 45 cm from

WTD1

$$Y = 253.87 + 6.19X_1 + 5.12X_2 + 0.58 \times 10^{-3} X_1 X_2 - 0.72 \times 10^{-3} X_1^2 - 0.86 \times 10^{-3} X_2^2, R^2 = 0.83$$

$$Y = 4.78 + 1.79X_1 + 0.11X_2 + 0.18 \times 10^{-3} X_1 X_2 - 0.20 \times 10^{-2} X_1^2 - 0.30 \times 10^{-3} X_2^2, R^2 = 0.88$$

* insignificant at 5% level

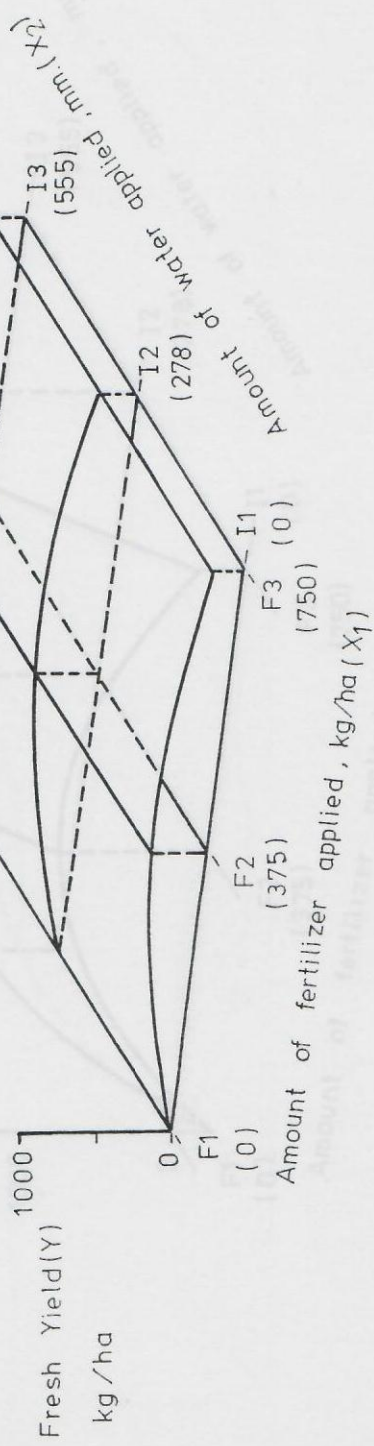

Fig. 4.7(1) Predicted Yield Response on Fertilizer and Irrigation Water Applied on WTD1-Plot

WTD2

$$Y = -253.67 + 6.19X_1 + 5.12X_2 + 0.52 \times 10^{-2} X_1 X_2 - 0.72 \times 10^{-2} X_1^2 - 0.86 \times 10^{-2} X_2^2, R^2 = 0.83$$

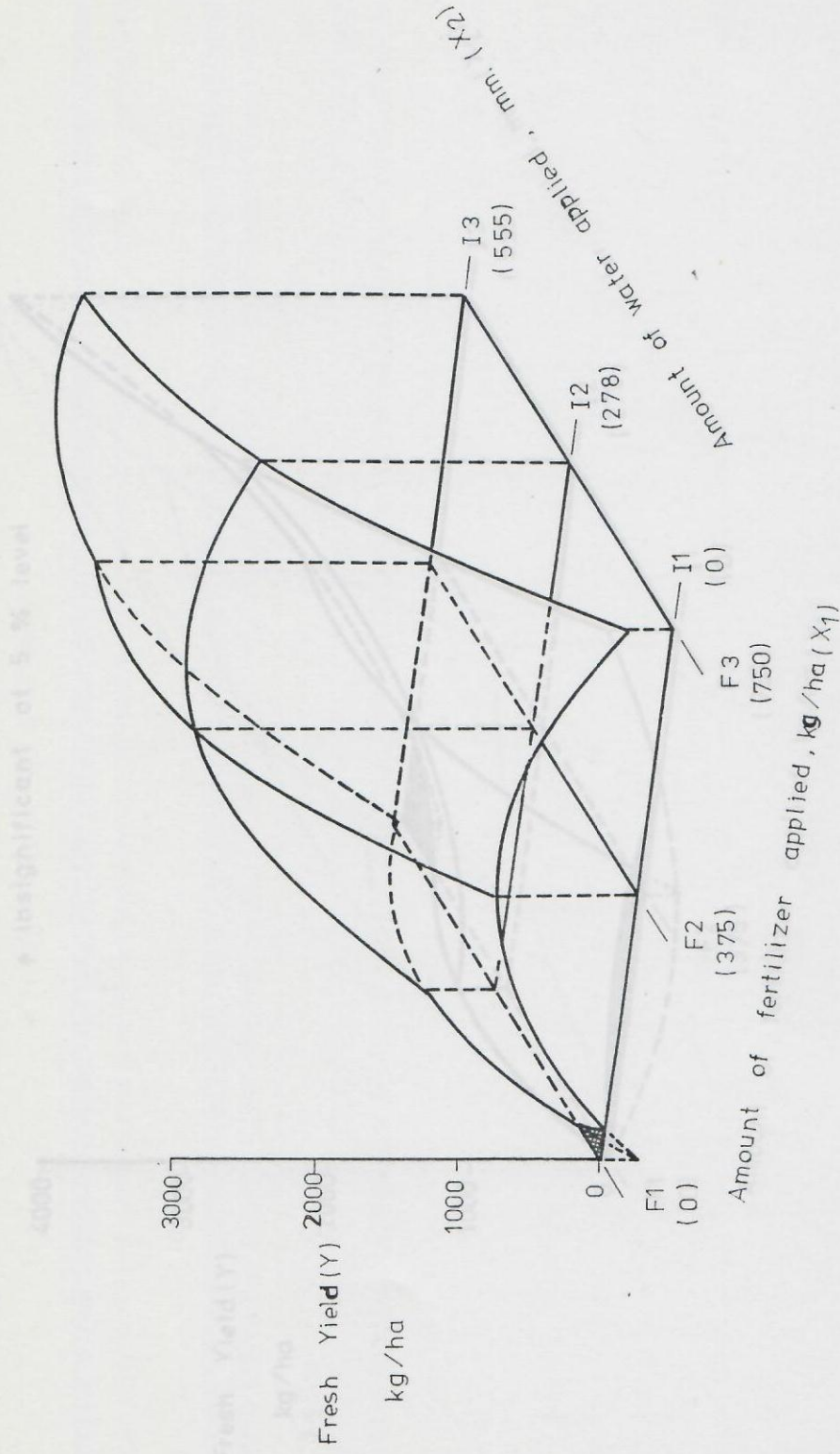

Fig. 4.7(2) Predicted Yield Response on Fertilizer and Irrigation Water Applied on WTD2-Plot

WTD3

$$Y = -16.62 - 1.89X_1 + 3.02X_2 + 0.72 \times 10^{-2} X_1 X_2 + 0.35 \times 10^{-2} X_1^2 - 0.62 \times 10^{-2} X_2^2, R^2 = 0.88$$

* insignificant at 5 % level

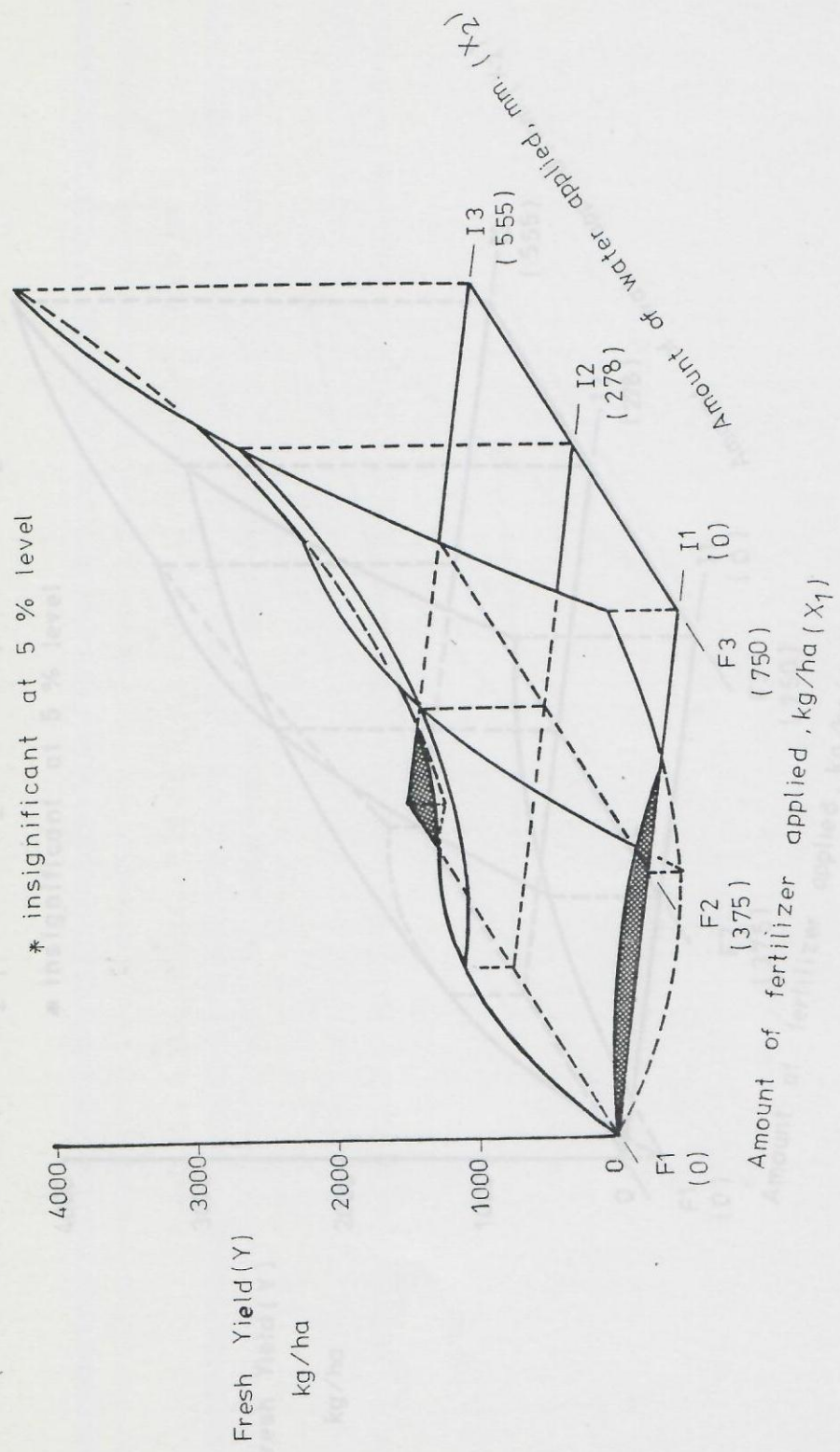

Fig. 4.7(3) Predicted Yield Response on Fertilizer and Irrigation Water Applied on WTD3-Plot

WTD4

$$Y = -269.48 + 3.65X_1 + 4.69X_2 + 0.39 \times 10^{-2} X_1 X_2 - 0.21 \times 10^{-2} X_1^2 - 0.68 \times 10^{-2} X_2^2, R^2 = 0.80$$

* insignificant at 5 % level

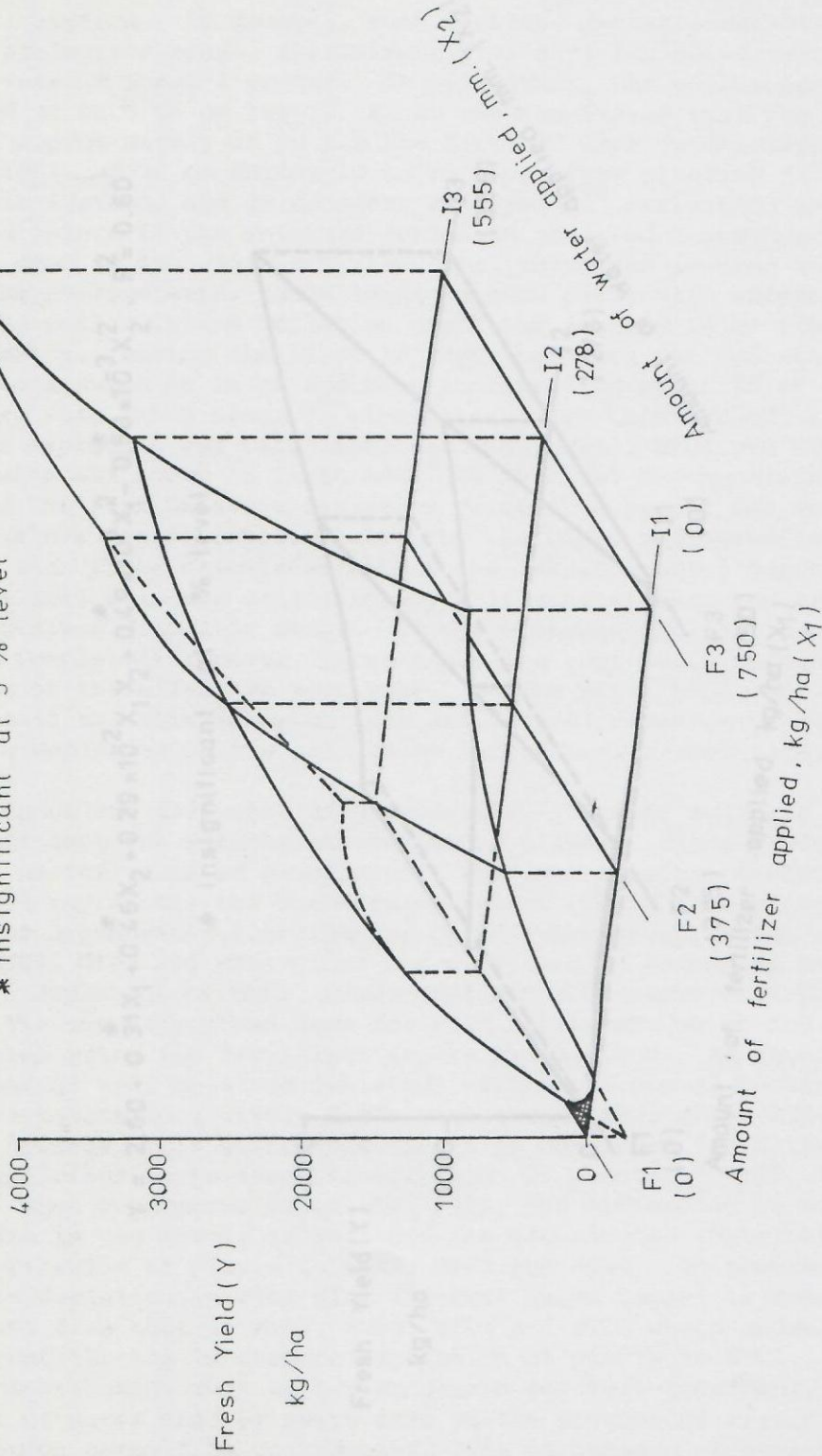

Fig. 4.7(4) Predicted Yield Response on Fertilizer and Irrigation Water Applied WTD4-Plot

WTD5

$$Y = 2.60 - 0.31X_1 + 0.46X_2 + 0.29 \times 10^{-2} X_1 X_2 + 0.49 \times 10^{-3} X_1^2 + 0.50 \times 10^{-3} X_2^2, R^2 = 0.60$$

* insignificant at % level

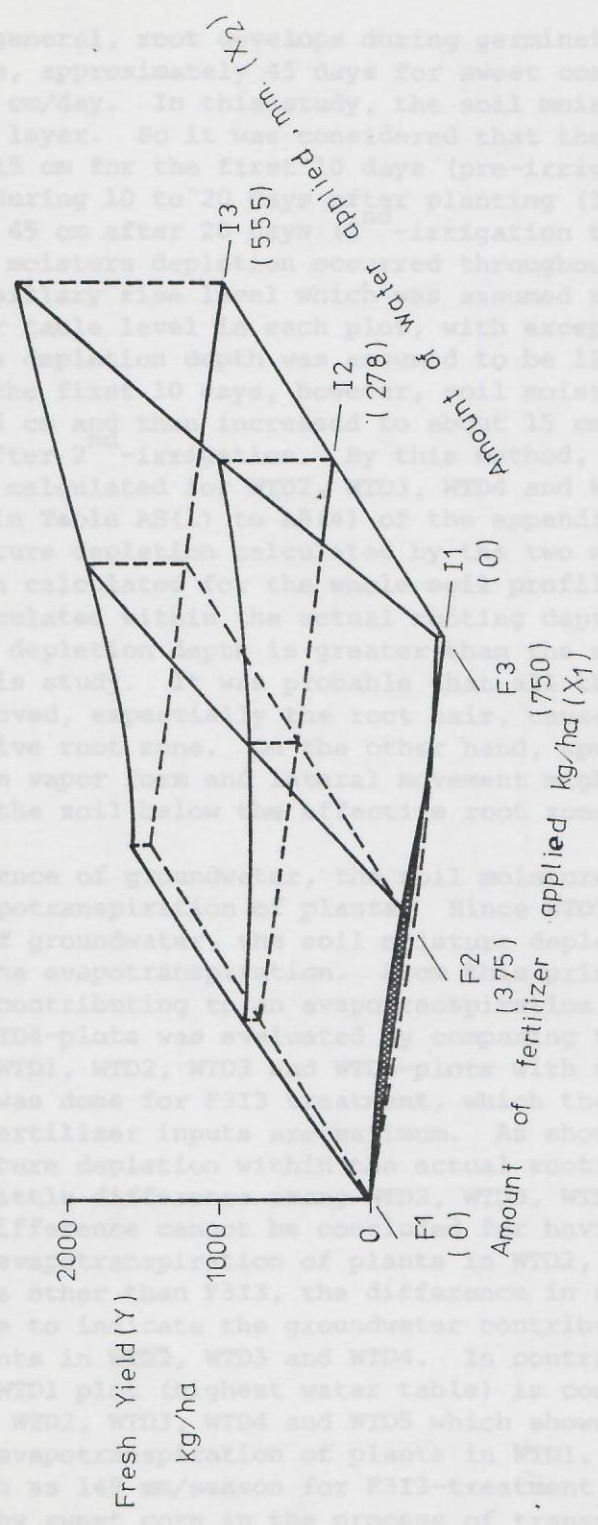

Fig. 4.7 (5) Predicted Yield Response on Fertilizer and Irrigation Water Applied on WTD5-Plot

the soil surface. In general, root develops during germination to the end of productive stage, approximately 45 days for sweet corn or root growth rate is about 1 cm/day. In this study, the soil moisture was measured at each 15 cm layer. So it was considered that the active root zone is approximately 15 cm for the first 10 days (pre-irrigation to 1st-irrigation) and 30 cm during 10 to 20 days after planting (1st-irrigation to 2nd-irrigation) and 45 cm after 20 days (2nd-irrigation to harvesting). A second method is the moisture depletion occurred throughout the soil profile down to the capillary rise level which was assumed to be 15 cm above the average water table level in each plot, with exception of WTD5 which the soil moisture depletion depth was assumed to be 120 cm from soil surface. During the first 10 days, however, soil moisture depletion depth was assumed at 15 cm and then increased to about 15 cm above the capillary rise level after 2nd-irrigation. By this method, so the soil moisture depletion was calculated for WTD2, WTD3, WTD4 and WTD5 only and the results are shown in Table A8(1) to A8(4) of the appendix. When compared the soil moisture depletion calculated by the two methods, the soil moisture depletion calculated for the whole soil profile is much greater than those calculated within the actual rooting depth, which shows that the soil moisture depletion depth is greater than the actual rooting depth obtained from this study. It was probable that all the root part was not completely removed, especially the root hair, caused the underestimate of the effective root zone. On the other hand, upward movement of the soil moisture in vapor form and lateral movement might cause the moisture depletion of the soil below the effective root zone.

Without the influence of groundwater, the soil moisture depletion will represent the evapotranspiration of plants. Since WTD5-plot was assumed no influence of groundwater, the soil moisture depletion in that plot represents the evapotranspiration. From this principle, the amount of groundwater contributing to an evapotranspiration of plants for WTD1, WTD2, WTD3 and WTD4-plots was evaluated by comparing the soil moisture depletion of WTD1, WTD2, WTD3 and WTD4-plots with that of WTD5-plot. The comparison was done for F3I3 treatment, which the amount of irrigation water and fertilizer inputs are maximum. As shown in Fig.4.8 the seasonal soil moisture depletion within the actual rooting depth of F3I3-treatments is a little difference among WTD2, WTD3, WTD4 and WTD5-plots, however, this difference cannot be concluded for having the groundwater contribution to evapotranspiration of plants in WTD2, WTD3 and WTD4-plots. Even treatments other than F3I3, the difference in soil moisture depletion is too little to indicate the groundwater contributing to evapotranspiration of plants in WTD2, WTD3 and WTD4. In contrast, the soil moisture depletion in WTD1 plot (highest water table) is considerable different from that in WTD2, WTD3, WTD4 and WTD5 which showed the groundwater contributing to evapotranspiration of plants in WTD1. The groundwater contribution much as 149 mm/season for F3I3-treatment, or about 45 percent of water used by sweet corn in the process of transpiration and evaporation comes from groundwater. The comparison of treatments other than F3I3-treatment also lead to the same conclusion that there are groundwater contribution to evapotranspiration of sweet corn in WTD1-plot.

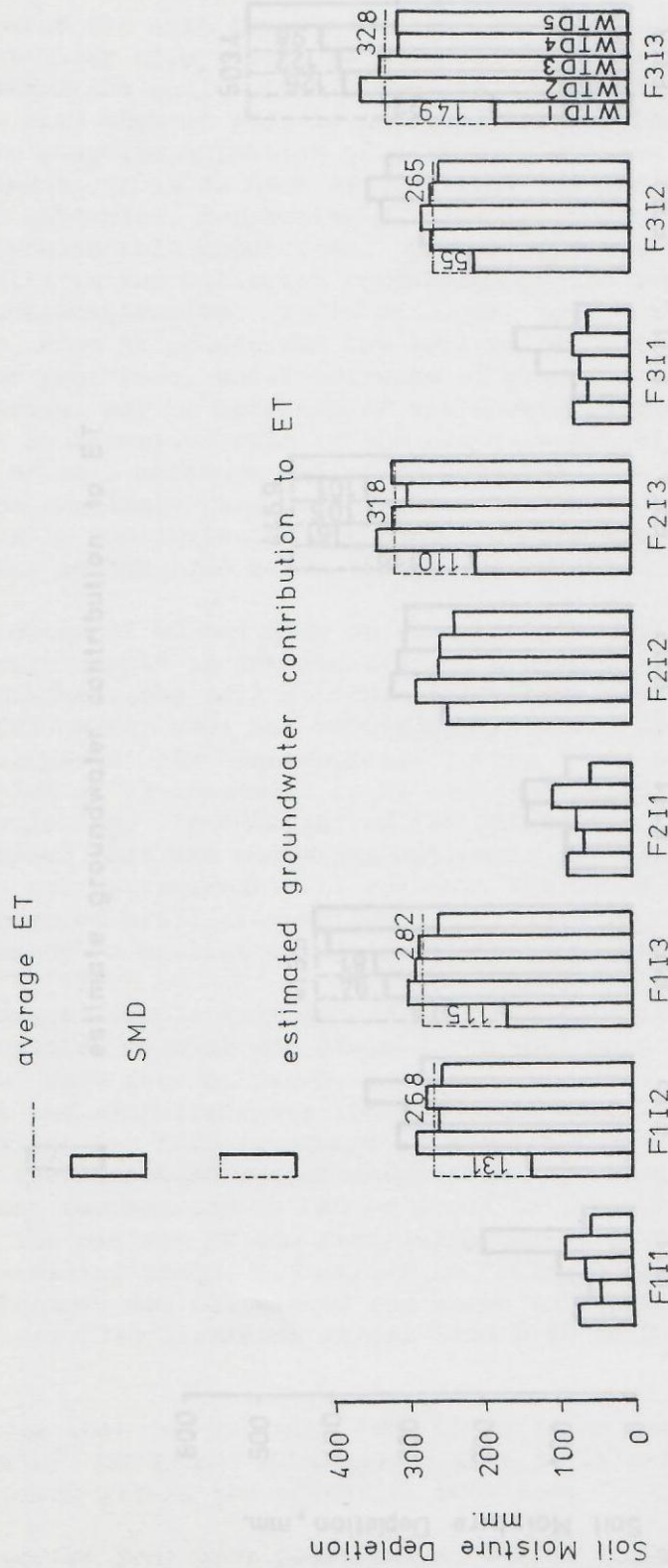

Fig 4.8 Bar Chart Showing the Comparison of the Soil Moisture Depletion (within the root zone) Among All Treatment Plots

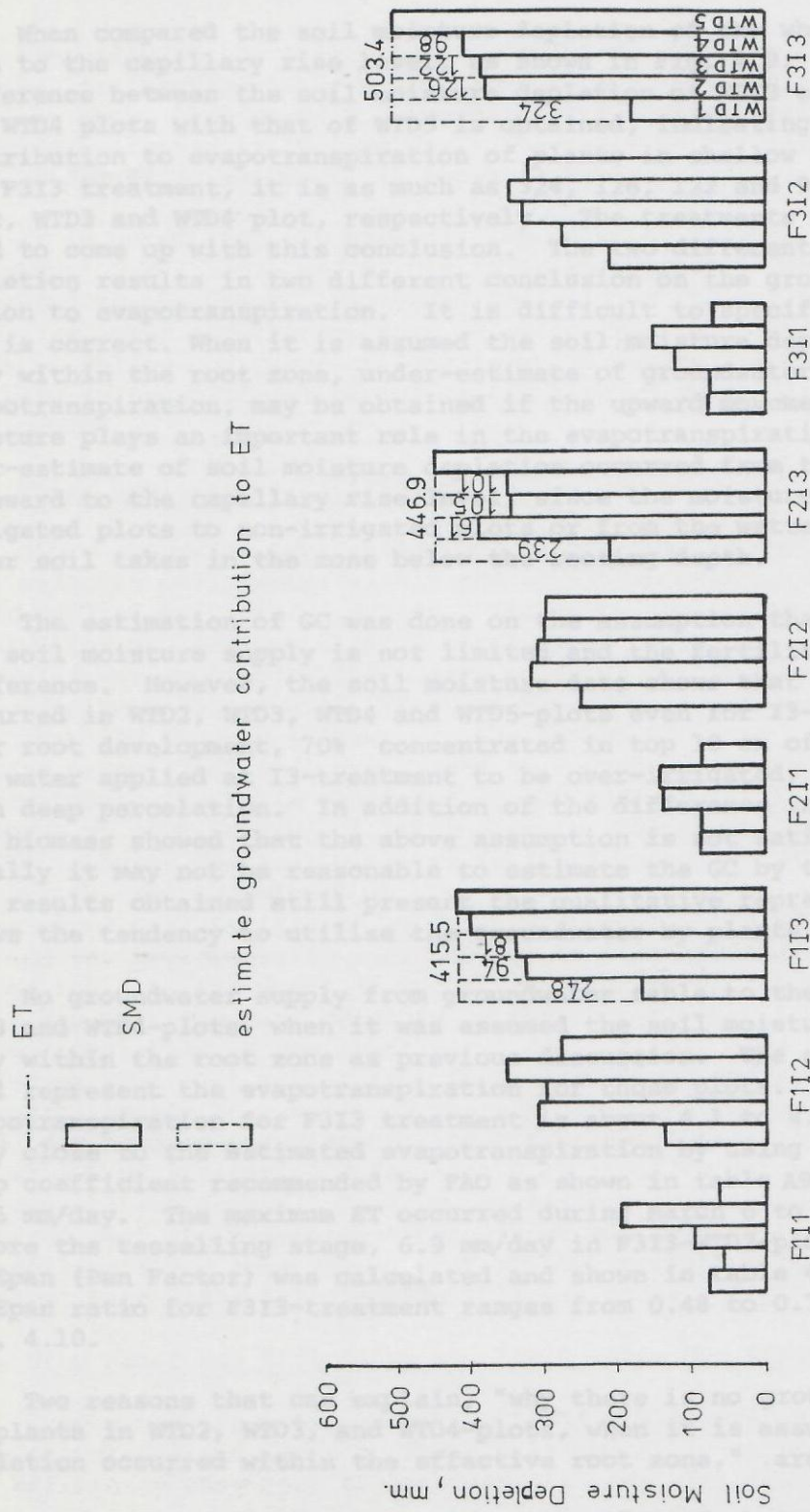

Fig 4.9 Bar Chart Showing the Comparison of the Soil Moisture Depletion (from the soil surface down to the capillary rise level) Among All Treatment Plots

When compared the soil moisture depletion of the whole soil profile down to the capillary rise level, as shown in Fig. 4.9. A significant difference between the soil moisture depletion of F3I3 of WTD1, WTD2, WTD3 and WTD4 plots with that of WTD5 is obtained, indicating the groundwater contribution to evapotranspiration of plants in shallow water table plots, for F3I3 treatment, it is as much as 324, 126, 122 and 98 mm in WTD1, WTD2, WTD3 and WTD4 plot, respectively. The treatments other than F3I3 tend to come up with this conclusion. The two different soil moisture depletion results in two different conclusion on the groundwater contribution to evapotranspiration. It is difficult to specify exactly which one is correct. When it is assumed the soil moisture depletion occurred only within the root zone, under-estimate of groundwater contribution to evapotranspiration, may be obtained if the upward movement of the soil moisture plays an important role in the evapotranspiration. In contrast, over-estimate of soil moisture depletion occurred from the soil surface downward to the capillary rise level, since the moisture movement from irrigated plots to non-irrigated plots or from the wetter soil to the drier soil takes in the zone below the rooting depth.

The estimation of GC was done on the assumption that at F3I3-treatment, the soil moisture supply is not limited and the fertility status is not difference. However, the soil moisture data shows that the water deficits occurred in WTD2, WTD3, WTD4 and WTD5-plots even for I3-treatment. Very poor root development, 70% concentrated in top 10 cm of soil, resulted that the water applied at I3-treatment to be over-irrigated, a lot of water loss as a deep percolation. In addition of the difference in growth rate, yield and biomass showed that the above assumption is not satisfactory. Statistically it may not be reasonable to estimate the GC by this way, however, the results obtained still present the qualitative representative which shows the tendency to utilize the groundwater by plants.

No groundwater supply from groundwater table to the plants in WTD2, WTD3 and WTD4-plots, when it was assumed the soil moisture depletion occurred only within the root zone as previous discussion. The soil moisture depletion will represent the evapotranspiration for those plots. The average daily evapotranspiration for F3I3 treatment is about 4.1 to 4.8 mm/day, which is very close to the estimated evapotranspiration by using pan coefficient and crop coefficient recommended by FAO as shown in table A9 of the appendix, 4.46 mm/day. The maximum ET occurred during March 6 to March 17 or just before the tesselling stage, 6.9 mm/day in F3I3-WTD2-plot. The Ratio of ET/Epan (Pan Factor) was calculated and shown in table 4.10. The average ET/Epan ratio for F3I3-treatment ranges from 0.48 to 0.76 as shown in Fig. 4.10.

Two reasons that can explain, "why there is no groundwater contribution to plants in WTD2, WTD3, and WTD4-plots, when it is assumed the soil moisture depletion occurred within the effective root zone," are

- i) unexpected poor root penetration, 70% of the root was being distributed in top 10 cm of soil.

- ii) water table dropped more than 30 cm from the beginning to the end of growing season

When assumed the soil moisture depletion occurred throughout the soil profile, the average daily evapotranspiration (Soil moisture depletion of WTD5) is about 50.3 cm or 6.6 mm/day for F3I3 treatment. The maximum evapotranspiration is 10.1 mm/day. The ratio of ET/Epan ranges from 0.54 to 1.18 for F3I3 treatment, as shown in Table 4.11.

It is noted that, in general, the ratio of ET/Epan (pan factor, Israelsen, O.W., 1962) and ET/Eto (crop coefficient, Jensen, M.E., 1973) increased as the season progressed and reached the maximum at around 100% effective cover and then dropped after the maximum. The experimental result tends to follow the curve of Israelsen and Jensen. However, the water deficits in the critical period caused a sharp valley in the curve during that period.

4.7 Water Application Efficiency

Since the water application efficiency (E_a) is defined as the ratio of soil moisture deficiency, within the effective root zone, over the irrigation water applied multiplying by 100. The water application efficiency for 9 combination of treatments and 5 water table depths are shown in Table 4.12. The water was applied to the plants by level furrow, so no runoff occurred and only deep percolation will effect on E_a . For I3 treatment, the E_a is always less than 100 percent indicating the amount of water applied exceeds the holding capacity of soil and losses as a deep percolation, but for most of I2 treatment, the E_a is greater than 100 percent (if E_a is greater than 100%, it shows at 100% in Table 4.12) indicating the amount of water applied is not enough to bring the soil moisture to field capacity. This leads to the conclusion that the amount of irrigation water applied should be less than I3 to avoid over-irrigation but greater than I2. In WTD1-plot, E_a of all combination treatments is very low due to high soil moisture content before irrigation. As the depth of water table increases, E_a tends to increase which indicates that the soil moisture in the higher water table plots is always at higher level than in the lower water table plots. The E_a of I3 treatment excluding WTD1-plot ranges from 46 to 88 percent and averages about 70 percent so approximately 30 percent of the irrigation water applied at I3 treatment were lost as deep percolation. To reduce the lost or to increase the E_a , the amount of irrigation water should be about 70 percent of I3 or 0.84 times the evaporative demand. However, as previously discussed, water deficiencies occurred even at I3-treatment because of too long the irrigation interval. The soil moisture data showed that if the irrigation interval is less than 10 days, then water deficiencies will not occur.

4.8 Crop Water Use Efficiency and Field Water Use Efficiency

Crop water use efficiency (CWUE) and field water use efficiency (FWUE) were calculated and shown in Table 4.13 and 4.14, respectively. Both water use efficiency show that I2-treatment is more efficient than I3-treatment.

Table 4.10 Ratio of ET/Epan (Pan Factor), based on SMD within the root zone

Pe- riod	Date	Dura- tion	Epan mm.	F1I1	F1I2	F1I3	F2I1	F2I2	F2I3	F3I1	F3I2	F3I3
Pan Factor (ET/Epan) for WTD2												
1	Feb. 2 - Feb.11	10	56.7	0.41	0.46	0.39	0.35	0.42	0.35	0.44	0.41	0.41
2	Feb.12 - Feb.21	10	58.8	0.05	0.24	0.46	0.32	0.20	0.69	0.22	0.19	0.42
3	Feb.22 - Mar. 5	12	80.4	0.07	0.65	0.67	0.10	0.63	0.67	0.15	0.56	0.75
4	Mar. 6 - Mar.17	12	89.6	0.04	0.55	0.52	0.15	0.55	0.79	0.07	0.59	0.93
5	Mar.18 - Apr. 2	16	125.3	0.06	0.44	0.45	0.03	0.44	0.52	0.00	0.38	0.56
6	Apr. 3 - Apr.11	9	67.6	0.00	0.82	0.78	0.001	0.86	0.82	0.05	0.79	0.85
7	Apr.12 - Apr.17	6	41.8	0.00	0.83	0.89	0.00	0.76	0.74	0.00	0.67	0.94
Pan Factor (ET/Epan) for WTD3												
1	Feb. 2 - Feb.11	10	56.7	0.46	0.39	0.37	0.46	0.46	0.42	0.46	0.42	0.42
2	Feb.12 - Feb.21	10	58.8	0.20	0.44	0.57	0.36	0.41	0.49	0.27	0.41	0.64
3	Feb.22 - Mar. 5	12	80.4	0.10	0.51	0.66	0.16	0.47	0.60	0.15	0.58	0.75
4	Mar. 6 - Mar.16	11	82.0	0.08	0.40	0.59	0.07	0.52	0.76	0.09	0.53	0.71
5	Mar.17 - Apr. 1	16	124.8	0.08	0.41	0.44	0.06	0.40	0.51	0.06	0.43	0.54
6	Apr. 2 - Apr.10	9	69.1	0.00	0.74	0.62	0.03	0.68	0.80	0.00	0.71	0.79
7	Apr.11 - Apr.17	7	48.5	0.04	0.72	0.74	0.06	0.57	0.77	0.06	0.74	0.64
Pan Factor (ET/Epan) for WTD4												
1	Feb. 2 - Feb.11	10	56.7	0.55	0.56	0.51	0.48	0.46	0.46	0.51	0.55	0.55
2	Feb.12 - Feb.21	10	58.8	0.31	0.69	0.60	0.31	0.56	0.57	0.07	0.45	0.50
3	Feb.22 - Mar. 4	11	74.3	0.07	0.43	0.56	0.21	0.42	0.58	0.15	0.52	0.60
4	Mar. 5 - Mar.16	12	88.1	0.14	0.48	0.48	0.20	0.56	0.62	0.18	0.63	0.67
5	Mar.17 - Mar.31	15	115.7	0.21	0.45	0.47	0.14	0.42	0.50	0.12	0.45	0.52
6	Apr. 1 - Apr.10	10	78.2	0.00	0.53	0.57	0.04	0.52	0.64	0.04	0.49	0.65
7	Apr.11 - Apr.17	7	48.5	0.00	0.68	0.71	0.26	0.51	0.62	0.04	0.55	0.69
Pan Factor (ET/Epan) for WTD5												
1	Feb. 2 - Feb.12	11	63.5	0.54	0.54	0.54	0.55	0.55	0.54	0.54	0.54	0.54
2	Feb.13 - Feb.22	10	59.5	0.07	0.35	0.31	0.15	0.44	0.48	0.17	0.50	0.50
3	Feb.23 - Mar. 6	12	80.0	0.09	0.39	0.47	0.06	0.36	0.55	0.05	0.47	0.55
4	Mar. 7 - Mar.17	11	82.5	0.01	0.50	0.57	0.04	0.50	0.70	0.04	0.51	0.71
5	Mar.18 - Mar.30	13	97.5	0.04	0.47	0.45	0.03	0.41	0.64	0.01	0.35	0.52
6	Mar.31 - Apr. 9	10	86.1	0.02	0.56	0.57	0.002	0.47	0.66	0.001	0.51	0.68
7	Apr.10 - Apr.18	9	56.4	0.08	0.54	0.50	0.05	0.37	0.59	0.05	0.51	0.60

Table 4.11 Ratio of ET/Epan (Pan Factor), based on SMD of 120 cm soil profile

Pe- riod	Date	Dura- tion	Epan mm.	Pan Factor (ET/Epan) for WTD5											
				F1I1	F1I2	F1I3	F2I1	F2I2	F2I3	F3I1	F3I2	F3I3			
1	Feb. 2 - Feb. 12	11	63.5	0.54	0.54	0.54	0.55	0.55	0.54	0.54	0.54	0.54	0.54	0.54	0.54
2	Feb. 13 - Feb. 22	10	59.5	0.00	0.46	0.43	0.07	0.78	0.43	0.77	0.17	0.17	0.75	0.79	0.79
3	Feb. 23 - Mar. 6	12	80.0	0.18	0.21	0.84	0.15	0.42	0.78	0.12	0.12	0.46	0.78	0.78	0.78
4	Mar. 7 - Mar. 17	11	82.5	0.03	0.51	0.92	0.19	0.66	1.11	0.07	0.07	0.71	1.18	1.18	1.18
5	Mar. 18 - Mar. 30	13	97.5	0.04	0.62	0.76	0.08	0.53	0.98	0.05	0.05	0.57	1.03	1.03	1.03
6	Mar. 31 - Apr. 9	10	86.1	0.08	0.68	1.03	0.06	0.54	0.66	0.01	0.01	0.64	1.17	1.17	1.17
7	Apr. 10 - Apr. 18	9	56.4	0.02	0.66	0.89	0.10	0.52	1.07	0.10	0.10	0.62	1.09	1.09	1.09

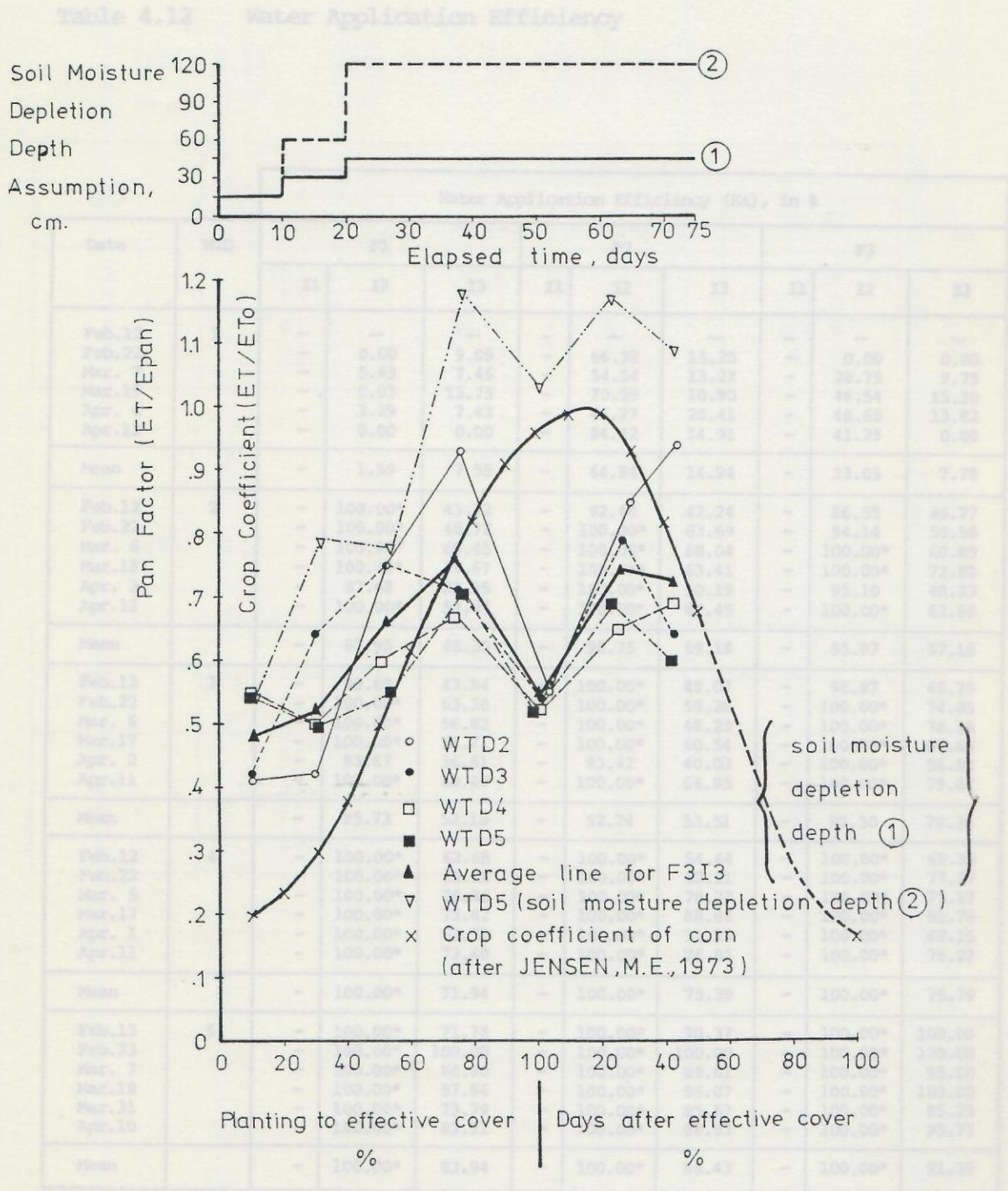

Fig 4.10 Curves Comparing Pan Factor of F3I3 Treatment and Crop Coefficient of Corn of JENSEN, M.E.

Table 4.12 Water Application Efficiency

Table 4.13 Crop Water Use Efficiency

		Water Application Efficiency (Ea), in %								
Date	WID	F1			F2			F3		
		I1	I2	I3	I1	I2	I3	I1	I2	I3
Feb.12	1	-	-	-	-	-	-	-	-	-
Feb.22		-	0.00	9.09	-	66.38	15.25	-	0.00	0.00
Mar. 7		-	5.63	7.46	-	54.54	13.21	-	28.75	9.79
Mar.19		-	0.03	13.75	-	70.59	10.90	-	46.54	15.30
Apr. 4		-	2.29	7.43	-	48.27	20.41	-	48.65	13.82
Apr.12		-	0.00	0.00	-	84.42	14.91	-	41.29	0.00
Mean		-	1.59	7.55	-	64.84	14.94	-	33.05	7.78
Feb.12	2	-	100.00*	43.32	-	92.48	42.24	-	86.55	46.77
Feb.22		-	100.00*	48.72	-	100.00*	63.69	-	94.14	50.56
Mar. 6		-	100.00*	60.45	-	100.00*	68.04	-	100.00*	60.89
Mar.18		-	100.00*	39.67	-	100.00*	63.41	-	100.00*	72.80
Apr. 3		-	87.68	32.85	-	100.00*	50.19	-	95.10	48.23
Apr.12		-	100.00*	53.07	-	100.00*	67.49	-	100.00*	63.68
Mean		-	97.95	46.35	-	98.75	59.18	-	95.97	57.16
Feb.12	3	-	90.69	43.84	-	100.00*	48.07	-	96.97	48.75
Feb.22		-	100.00*	63.20	-	100.00*	59.26	-	100.00*	74.05
Mar. 6		-	100.00*	56.82	-	100.00*	48.23	-	100.00*	78.38
Mar.17		-	100.00*	51.71	-	100.00*	60.54	-	100.00*	84.64
Apr. 2		-	83.67	36.61	-	83.42	40.03	-	100.00*	56.82
Apr.11		-	100.00*	60.40	-	100.00*	64.95	-	100.00*	79.62
Mean		-	95.73	52.10	-	92.24	53.51	-	99.50	70.38
Feb.12	4	-	100.00*	62.68	-	100.00*	54.44	-	100.00*	69.36
Feb.22		-	100.00*	82.22	-	100.00*	82.21	-	100.00*	77.27
Mar. 5		-	100.00*	76.36	-	100.00*	78.22	-	100.00*	75.27
Mar.17		-	100.00*	73.42	-	100.00*	88.88	-	100.00*	91.76
Apr. 1		-	100.00*	63.57	-	100.00*	71.16	-	100.00*	68.15
Apr.11		-	100.00*	73.40	-	100.00*	76.85	-	100.00*	78.27
Mean		-	100.00*	71.94	-	100.00*	75.39	-	100.00*	76.79
Feb.13	5	-	100.00*	71.78	-	100.00*	70.37	-	100.00*	100.00
Feb.23		-	100.00*	100.00	-	100.00*	100.00	-	100.00*	100.00
Mar. 7		-	100.00*	86.90	-	100.00*	89.61	-	100.00*	95.60
Mar.18		-	100.00*	87.86	-	100.00*	96.07	-	100.00*	100.00
Mar.31		-	100.00*	73.79	-	100.00*	85.57	-	100.00*	85.23
Apr.10		-	100.00*	83.31	-	100.00*	88.93	-	100.00*	95.77
Mean		-	100.00*	83.94	-	100.00*	88.43	-	100.00*	91.38

* under-irrigation

CONCLUSION

Table 4.13 Crop Water Use Efficiency

WTD	CWUE (kg/ha-cm)			
	F2I2	F2I3	F3I2	F3I3
2	103.4	70.5	93.4	77.4
3	53.4	28.1	121.5	113.0
4	97.1	85.0	137.1	109.6
5	20.7	17.2	31.4	47.3

Table 4.14 Field Water Use Efficiency

WTD	FWUE (kg/ha-cm)			
	F2I2	F2I3	F3I2	F3I3
2	90.6	37.9	79.0	45.3
3	33.1	11.1	93.0	57.3
4	75.4	40.9	106.0	56.6
5	15.5	9.2	26.2	25.4

V CONCLUSION

VI RECOMMENDATION FOR FURTHER STUDY

The **conclusions** drawn from this study include the basic information for the potentiality in utilizing the groundwater from the shallow water table region and other complementary results as follows:

1. Maximum yield of sweet corn is 3,260 kg/ha at F3I3 treatment in WTD3-plot, a slightly lesser yield of 3,200 kg/ha and 3,000 kg/ha are obtained from WTD4-plot at F3I3-treatment and F3I2 treatment, respectively. Yield of WTD5-plot is less than 1,500 kg/ha and yield of WTD1-plot is less than 500 kg/ha, due to water deficiencies and oxygen deficiencies, respectively. Yield is zero at F1I1 treatment in all WTD-plots. Pest attack at the beginning of the tasselling stage might be a major effect on the reduction of yield in all plots.
2. Based on the soil moisture depletion study within the root zone of F3I3-WTD2 plot, the water requirements of sweet corn is 36.0 cm or 4.8 mm/day, while based on the soil moisture depletion study throughout the whole soil profile of F3I3-WTD5 plot, the water requirements is 50.3 cm or 6.6 mm/day.
3. Based on the soil moisture depletion study within the root zone, approximately 15.0 cm of water is supplied from the groundwater to plants in WTD1-plot but no groundwater contribution to evapotranspiration of plants in WTD2, WTD3, WTD4 plots, while the soil moisture depletion study throughout the whole soil profile results in 32.4, 12.6, 12.2, 9.8 cm of the groundwater contribution to plants in WTD1, WTD2, WTD3, WTD4 plots, respectively.
4. Irrigation interval should not exceed 10 days to avoid water deficits, for this particular study.
5. Groundwater fluctuates with the general tendency to drop from February to April, and as much as 40 cm in WTD1 and WTD2-plots.
6. No salinity hazard was found in groundwater.
7. Actual root distribution was found primarily in the top 45 cm of soil; 70% of root is in top 10 cm, 20% between 10-20 cm from soil surface, almost 10% between 20-30 cm and a few percent deeper than 30 cm from soil surface. This is due to the soil of very poor structure, high bulk density, limits the root penetration and results in low yield.

REFERENCES

VI RECOMMENDATION FOR FURTHER STUDY

- ABDALLA, M.M. (1974), Studies on Physical and Chemical Soil Properties in Relation to Soil Productivity, FAO report of Experimental and
- The study of groundwater contribution to evapotranspiration of plants in lysimeter with control of the water table at end of root zone and at prespecified depths below the root zone would be very useful.
- (1972), Evapotranspiration by Cotton as Effected by the Depth of Water Table, Irrigation and Drainage Paper, No. 13, EAD, Rome, pp. 103-110
- BERRY, O.L., and BOSS, B.D. (1960), Effect of Soil Moisture Level on Root Distribution of Cool Season Forage Species, Agron. J., Vol. 52, pp. 204-207
- DEBHEAD, O.T. and SHAW, R.H. (1960), The Effect of Soil Moisture Stress at Different Stages of Growth on the Development and Yield of Corn, Agron. J., Vol. 52, pp. 272-274
- DEBHEAD, O.T. and SHAW, R.H. (1962), Availability of Soil Water to Plants as Affected by Soil Moisture Content and Meteorological Condition, Agron. J., Vol. 54, pp. 385-390
- DIBBOLD, C.H. (1935), Some Relationships Between Soil Type and Forest Site Quality, Ecology, Vol. 16, pp. 640-647
- EDEN, A., ALIEMAN, G., BAUER, C.J.L., NICHOLSON, R.H., and FIRSH, R.H. (1951), The Effect of Ground Water Level Upon Productivity and Composition of Peatland Grass, Journ. Agric. Sci., Vol. 41, pp. 191-203
- GILBERT, W.B., and CHAMBERLAIN, D.S. (1959), Effect of Depth of Water Table on Yield of Ladino Clover, Orchardgrass, and Tall Fescue, Agron. J., Vol. 48, pp. 517-520
- GOINS, T., LUNIN, J., and WORLEY, R.L. (1966), Water Table Effects on Growth of Tomatoes, Snap Beans and Sweet Corns, Trans. of the ASAE, Vol. 9, pp. 530-533
- HAGAN, R.H., PETERSON, M.L., UPCHURCH, R.P., and JONES, L.G. (1957), Relationships of Soil Moisture Stress to Different Aspects of Growth in Ladino Clover, Soil Sci. Soc. Amer. Proc., Vol. 21, pp 360-365
- HAROLD, L.I. (1955), Evapotranspiration Rate for Various Crops, Agric. Eng., Vol. 36, pp. 669-672
- HAROLD, L.J., PETERS, D.B., DEIRKELIS, L.R., and McGUINNESS, J.L. (1959), Transpiration Evaluation of Corn Grown on a Plastic Covered Lysimeter, Soil Sci. Soc. Amer. Proc., Vol. 23, pp. 174-178
- HILKE, F.A. (1969), Quantitative Evaluation of Crop Drainage Requirements, Trans. of the ASAE, Vol. 12, pp. 499-505

REFERENCES

- ABDALLA, M.M. (1974), Studies on Physical and Chemical Soil Properties in Relation to Soil Productivity, FAO report of Experimental and Demonstration for Irrigated Agriculture Kalasin, Thailand, pp. 48-56
- BARAKAT, M.A., EL SHABASSY, A.I., EL CHAMRY, W.M., and MOHAMED, N.A. (1972), Evapotranspiration by Cotton as Effected by the Depth of Water Table, Irrigation and Drainage Paper, No. 13, FAO, Rome, pp. 103-110
- BENNETT, O.L., and DOSS, B.D. (1960), Effect of Soil Moisture Level on Root Distribution of Cool Season Forage Species, Agron. J., Vol. 52, pp. 204-207
- DENMEAD, O.T., and SHAW, R.H. (1960), The Effect of Soil Moisture Stress at Different Stages of Growth on the Development and Yield of Corn, Agron. J., Vol. 52, pp. 272-274
- DENMEAD, O.T. and SHAW, R.H. (1962), Availability of Soil Water to Plants as Affected by Soil Moisture Content and Meteorological Condition, Agron. J., Vol. 54, pp. 385-390
- DIEBOLD, C.H. (1935), Some Relationships Between Soil Type and Forest Site Quality, Ecology, Vol. 16, pp. 640-647
- EDEN, A., ALDERMAN, G., BAKER, C.J.L., NICHOLSON, H.H., and FIRTH, D.H. (1951), The Effect of Ground Water Level Upon Productivity and Composition of Fenland Grass, Journ. Agric. Sci., Vol. 41, pp. 191-202
- GILBERT, W.B., and CHAMBLEE, D.S. (1959), Effect of Depth of Water Table on Yield of Ladino Clover, Orchardgrass, and Tall Fescue, Agron. J., Vol. 48, pp. 517-520
- GOINS, T., LUNIN, J., and WORLEY, R.L. (1966), Water Table Effects on Growth of Tomatoes, Snap Beans and Sweet Corns, Trans. of the ASAE, Vol. 9, pp. 530-533
- HAGAN, R.M., PETERSON, M.L., UPCHURCH, R.P., and JONES, L.G. (1957), Relationships of Soil Moisture Stress to Different Aspects of Growth in Ladino Clover, Soil Sci. Soc. Amer. Proc., Vol. 21, pp 360-365
- HARROLD, L.I. (1955), Evapotranspiration Rate for Various Crops, Agric. Eng., Vol. 36, pp. 669-672
- HARROLD, L.J., PETERS, D.B., DREIBELBIS, L.R., and McGUINNESS, J.L. (1959), Transpiration Evaluation of Corn Grown on a Plastic Covered Lysimeter, Soil Sci. Soc. Amer. Proc., Vol. 23, pp. 174-178
- HILER, E.A. (1969), Quantitative Evaluation of Crop Drainage Requirements, Trans. of the ASAE, Vol. 12, pp. 499-505

- HOLMES, R.M., and ROBERTSON, G.W. (1963), Application of the Relationship Between Actual and Potential Evapotranspiration in Dry Land Agriculture, Trans. of the ASAE, Vol. 6, pp. 65-67
- HOLT, R.F., and Van DOREN, C.A. (1961), Water Utilization by Field in Western Minnesota, Agron. J., Vol. 54, pp. 43-45
- HUSCHKE, R.E. (1959), Glossary of Meteorology, Amer. Meteorol. Soc., Boston, pp. 638
- ISRAELSEN, O.W., and HANSEN, V.E. (1962), Irrigation Principles and Practices (Third edition), John Wiley and Sons, Inc., New York
- JENSEN, C.A. (1918), Relation of Inorganic Soil Colloids to Plowsole in Citrus Groves in Southern California, Journ. Agric. Res., Vol. 15, pp. 505-519
- JENSEN, M.E. (1973), Consumptive Use of Water and Irrigation Water Requirements, American Society of Civil Engineers, pp. 88
- KEEN, G.A. (1927), The Limited Role of Capillarity in Supplying Water to Roots, Soil Science, Vol. 1, pp. 504-514
- KLAGES, M.G., and ASLESON, J.A. (1959), Relationship Between Botanical Composition, Nitrogen Response, and Water Table Level on Wet Meadow Sod, Agron. J., Vol. 51, pp. 562-565
- KRAMER, P.J. (1969), Plant and Soil Water Relationships: A Modern Synthesis, McGraw-Hill Book Company, New York
- LAL, P., and SHARMA, K.C. (1973), Productivity in Dwarf Wheats in a Silt-Loam Soil as Influenced by Soil Moisture Regimes and Shallow Water Table Conditions, Indian J. Agric. Sci., Vol. 43, pp. 255-261
- LAL, P., and SHARMA, K.L. (1976), Predicting Water Needs of Wheat from USWB Class A Pan Evaporation at Pantnagar, India, Expl. Agric., Vol. 12, pp. 23-31
- LEVIT, J. (1972), Responses of Plants to Environmental Stress, Academic Press, New York
- MICHAEL, A.M. (1978), Irrigation Theory and Practice, Vikas Publishing House A/T, Ltd, New Delhi, pp. 547
- NICHOLSON, H.H., and FIRTH, H.H. (1953), The Effect of Ground Water Level on the Performance and Yield of Some Common Crops, Jour. Agric. Sci., Vol. 43, pp. 95-104
- PANDEY, S.N., and SINHA, B.K. (1972), Plant Physiology, Vikas Publishing House PVT Ltd., New Delhi

- PHILLIPS, R.E., and KIRKHAM, D. (1962a), Soil Compaction in the Field and Corn Growth, Agron. J., Vol. 54, pp. 29-34
- PHILLIPS, R.E., and KIRKHAM, D. (1962b), Mechanical Impedance and Corn Seedling Root Growth, Soil Sci. Soc. Amer. Proc., Vol. 26, pp. 319-322
- POOMVISES, V., MOORNMANN, F.R., and MONTRAKUN, S. (1963), Detail Reconnaissance Soil Survey of the Lam Pao Irrigation Project, Kalasin, Thailand, Miscellaneous Soil Reports of the Royal Irrigation Department, Département of Agriculture and the Department of Rice, Ministry of National Development, Report MSR-12-1963, pp. 2-8
- ROBINS, J.S., and DOMINGO, C.E. (1953), Some Effects of Severe Soil Moisture Deficits at Specific Growth Stages of Corn, Agron. J., Vol. 45, pp. 618-621
- RUSSELL, M.B., DAVIS, F.E., and BLAIR, R.E. (1940), The Use of Tensiometer for Following Soil Moisture Condition under Corn, Agron. J., Vol. 32, pp. 922-930
- SHAW, R.H., LAING, D.R. (1965), Moisture Stress and Plant Response, Plant Environment and Efficient Water Use, PIERRE, W.H. (ed.), American Society of Agronomy and Soil Science Society of America, Madison, Wisconsin, pp. 79-82
- TACKETT, J.L., and PEARSON, R.W. (1964), Oxygen Requirements for Cotton Seedling Root Penetration of Compacted Soil Cores, Soil Sci. Soc. Amer. Proc., Vol. 28, pp. 600-605
- TAYLOR, H.M., and BURNETT, E. (1964), Influence of Soil Strength on the Root Growth Habits of Plants, Soil Sci., Vol. 98, pp. 174-180
- TALUKDER, M.S.U. (1978), Dry Season Water Utilization Studies of Selected Crops in the North-East of Thailand, AIT MS. Thesis
- TOVEY, R. (1964), Alfalfa Growth as Influenced by Static and Fluctuating Water Tables, Trans. of the ASAE, Vol. 7, pp. 310-312
- TURNER, L.M. (1936), Root Growth of Seedling of Pinus Echinata and Pinus Taeda, Journ. Agric. Res., Vol. 53, pp. 145-149
- Van HOORNE, J.W. (1958), Results of a Ground Water Level Experimental Field with Arable Crops on Clay Soil, Nerth. J. Agric. Sci., Vol. 6, pp. 1-10
- Van SCHILFGAARDE, J., and WILLIAMSON, R.E. (1956), Studied of Crop Response to Drainage, Trans. of the ASAE, Vol. 8, pp. 94-102
- WEAVER, H.A. and STEPHENSON, J.C. (1963), Relation of Evapotranspiration to Potential Evapotranspiration, Trans. of the ASAE. Vol. 8, pp. 55-56

APPENDIX

WEAVER, J.E. (1925), Investigation on the Root Habits of Plants, Amer. J. Bot., Vol. 12, pp. 502-509

WEAVER, J.E., and CLEMENTS, F.E. (1938), Plant Ecology, McGraw-Hill Book Company, New York

WESSELLING, J., and WIJK, W.R. (1957), Land Drainage in Relation to Soils and Crops, Drainage of Agricultural Lands; LUTHIN, J.N.(ed.), Agronomy No. 7, American Society of Agronomy, Inc., Publisher, Madison, Wisconsin, pp. 498-503

WESSELLING, J. (1974), Crop Growth and Wet Soils, Drainage for Agriculture van SCHILFGAARDE, J. (ed.), Agronomy No. 17, American Society of Agronomy, Inc., Publisher, Madison, Wisconsin, pp. 32-37

WIDTSOE, J.A. (1912), The Predicted of Dry Matter with Different Quantities of Water, Utah Agr. Expt. Sta. Bull., No. 16, pp 64

WIERSMA, D.C. (1959), The Soil Environment and Root Development, Advances in Agronomy; NORMAL, G.A. (ed.), Vol. 11, pp. 46

WILLIAMSON, R.E. (1968), Effect of Water Table Depth and Method of Watering on Yield of Stringbeans, Agron. J., Vol. 60, pp. 242-244

WILLIAMSON, R.E., and CARRECKER, J.R. (1970), Effect of Water Table Levels on Evapotranspiration and Crop Yield, Trans. of the ASAE, Vol. 13, pp. 168-170, 176

WILLIAMSON, R.E., and KRIZ, G.J. (1970), Response of Agricultural Crops to Flooding, Depth of Water Table and Soil Gases Composition, Trans. of the ASAE, Vol. 13, pp. 216-220

WILLIAMSON, R.E., and WILLEY, C.R. (1964), Effect of Depth of Water Table on Yield of Tall Fescue, Agron. J., Vol. 56, pp. 585-588

24	6.70	-	4	8.13	-
25	6.79	-	5	7.40	-
26	6.97	-	6	9.12	-
27	6.01	-	7	8.71	-
28	6.68	-	8	8.03	-
Mar. 1	6.10	-	9	8.05	-
2	7.33	-	10	2.72	-
3	5.24	-	11	6.70	-
4	6.10	-	12	9.02	-
5	7.15	-	13	6.47	-
6	7.98	-	14	8.84	-
7	6.66	-	15	7.45	-
8	7.55	-	16	3.56	2.0
9	7.59	-	17	6.41	-
10		-	18	5.21	-

APPENDIX

Table A1 Daily Evaporation and Rainfall Observed at Experimental Site During the Entire Growing Season, Dry Season 1979

Date	Evaporation (mm)	Rainfall (mm)	Date	Evaporation (mm)	Rainfall (mm)
Feb. 1	5.78	-	Mar. 11	6.82	-
2	6.51	-	12	6.94	-
3	5.56	-	13	7.45	-
4	5.42	-	14	8.05	-
5	5.54	-	15	8.23	-
6	6.32	-	16	7.66	-
7	5.99	-	17	7.60	-
8	5.78	-	18	6.98	-
9	5.28	-	19	8.91	-
10	5.12	4.0	20	6.37	-
11	5.21	-	21	7.92	-
12	6.83	-	22	7.76	-
13	5.77	-	23	6.47	-
14	5.41	-	24	7.11	-
15	5.59	-	25	6.16	-
16	5.61	-	26	5.84	-
17	5.78	-	27	8.80	-
18	4.98	-	28	9.08	-
19	5.52	-	29	7.54	-
20	6.62	-	30	9.23	-
21	6.67	-	31	10.63	-
22	7.56	-	Apr. 1	9.06	-
23	7.23	-	2	8.18	-
24	7.69	-	3	8.24	-
25	6.70	-	4	8.19	-
26	6.79	-	5	7.40	-
27	6.97	-	6	9.12	-
28	6.01	-	7	8.71	-
Mar. 1	6.68	-	8	8.03	-
2	6.10	-	9	8.05	-
3	7.33	-	10	2.72	-
4	5.24	-	11	6.70	-
5	6.10	-	12	9.02	-
6	7.15	-	13	6.47	-
7	7.88	-	14	8.84	-
8	6.66	-	15	7.45	-
9	7.55	-	16	3.56	2.0
10	7.59	-	17	6.41	-
			18	5.21	-

Table A2 Groundwater Table Record at Experimental Site During February, April 1979.

Date	MEAN WATER TABLE DEPTH OF THREE OBSERVATIONS, cm.															
	WTD1			WTD2			WTD3			WTD4			WTD5			
	1	** 2	3	1	** 2	3	1	** 2	3	1	** 2	3	1	** 2	3	
Feb. 10	40	33	30	71	75	67	85	87	82	82	128	132	127	*	*	*
17	34	33	30	61	66	60	84	86	82	82	122	128	131	*	*	*
24	35	32	30	62	63	61	84	86	82	82	121	126	128	*	*	*
Mar. 3	59	56	53	86	82	87	101	100	99	99	125	129	130	*	*	*
10	50	37	37	82	78	76	97	95	92	92	119	121	125	*	*	*
17	60	61	59	94	92	92	109	106	102	102	132	135	137	*	*	*
24	49	39	27	83	85	82	107	106	103	103	124	129	132	266	273	281
31	83	75	69	108	104	104	116	110	112	112	148	153	153	271	280	284
Apr. 7	67	58	56	98	96	94	116	114	113	113	132	137	141	272	278	281
14	88	79	66	116	114	112	134	133	131	131	150	154	154	273	280	283
16	80	72	54	114	110	106	127	125	122	122	140	145	148	274	280	283
Avg for Rep.	59	49	46	87	88	86	105	104	102	102	131	135	137	271	278	282
Avg for WTD	52			87			104			135			277			

* missing data since incomplete observation tube installation
 ** numbers (1,2,3) show location of the observation tube as shown in Fig. 3.2

Table A3 Height of Sweet Corn under Different Water Table Depth, Irrigation and Fertility Treatments.

WTD	Rep.	Height in cm.								
		F1			F2			F3		
		I1	I2	I3	I1	I2	I3	I1	I2	I3
1	1	51	25	24	125	127	109	123	120	100
	2	67	30	63	127	120	137	103	112	120
	3	47	33	24	*	*	*	126	131	*
2	1	*	70	46	*	191	122	*	213	189
	2	62	96	44	148	182	187	120	230	208
	3	52	88	54	102	162	166	105	211	172
3	1	49	62	58	96	149	105	113	210	198
	2	49	47	19	103	148	106	103	194	188
	3	64	65	35	86	178	150	111	187	193
4	1	45	54	66	114	184	190	152	213	191
	2	51	94	73	122	156	197	123	194	205
	3	57	117	115	108	218	190	168	199	178
5	1	44	60	114	46	115	145	44	124	168
	2	19	71	79	39	128	116	53	103	167
	3	14	35	29	38	84	76	50	93	110
Mean Height		48	63	56	96	153	143	107	169	171

* missing data

Table A4 Yield of Sweet Corn under Different Water Table Depths, Irrigation and Fertility Treatments.

Treatments		Yield (kg/ha)			Mean Yield (kg/ha)
		Rep.1	Rep.2	Rep.3	
		WTD1			
F1	I1	0.0	0.0	0.0	0.0
	I2	0.0	0.0	0.0	0.0
	I3	0.0	0.0	0.0	0.0
F2	I1	476.7	422.2	*	449.5
	I2	486.7	255.6	*	371.2
	I3	333.3	455.6	*	394.5
F3	I1	266.7	91.1	182.2	180.0
	I2	333.3	250.0	317.8	300.4
	I3	181.1	307.8	*	244.5
		WTD2			
F1	I1	*	0.0	0.0	0.0
	I2	0.0	222.2	377.8	200.0
	I3	0.0	0.0	0.0	0.0
F2	I1	*	1400.0	266.7	833.3
	I2	2111.1	3336.7	2377.8	2608.5
	I3	1511.1	3066.7	1977.8	2185.2
F3	I1	*	422.2	133.3	277.8
	I2	1754.4	3355.6	1711.1	2273.7
	I3	2733.3	3088.9	2000.0	2607.4
		WTD3			
F1	I1	0.0	0.0	0.0	0.0
	I2	0.0	0.0	0.0	0.0
	I3	0.0	0.0	0.0	0.0
F2	I1	0.0	113.3	0.0	37.8
	I2	611.1	111.1	2111.1	944.4
	I3	555.6	333.3	1000.0	629.6
F3	I1	333.3	222.2	222.2	259.3
	I2	2888.9	2777.8	2333.3	2666.7
	I3	3000.0	3000.0	3777.8	3259.3

Table A4 Yield of Sweet Corn under Different Water Table Depths, Irrigation and Fertility Treatments. (cont.)

Treatments	Yield (kg/ha)			Mean Yield (kg/ha)
	Rep.1	Rep.2	Rep.3	
WTD4				
F1 I1	0.0	0.0	0.0	0.0
I2	0.0	0.0	777.8	259.3
I3	0.0	0.0	533.3	177.8
F2 I1	0.0	111.1	1222.2	444.4
I2	1888.9	1111.1	3404.4	2134.8
I3	2444.4	2000.0	2500.0	2314.8
F3 I1	466.7	1666.7	1944.4	1359.3
I2	2000.0	3444.4	3555.6	3000.0
I3	4000.0	2944.4	2666.7	3203.7
WTD5				
F1 I1	0.0	0.0	0.0	0.0
I2	0.0	0.0	0.0	0.0
I3	488.9	111.1	0.0	200.0
F2 I1	0.0	0.0	0.0	0.0
I2	136.7	944.4	222.2	434.4
I3	771.1	466.7	306.7	514.8
F3 I1	0.0	0.0	0.0	0.0
I2	1111.1	646.7	431.1	729.6
I3	2688.9	1260.0	295.6	1414.8
WTD3				
*missing data	331.4	366.0	335.6	344.3
I2	275.7	204.0	393.6	311.1
I3	140.3	22.9	78.2	80.5
F2 I1	998.2	1140.9	580.2	906.4
I2	2058.6	2977.6	3156.3	2730.8
I3	1456.4	2659.9	1091.5	1735.9
F3 I1	1545.2	1661.0	1042.7	1416.3
I2	4733.5	5123.0	3445.7	4434.1
I3	4939.0	4136.3	4368.5	4481.3

Table A5 Dry Matter of Sweet Corn under Different Water Table Depths, Irrigation and Fertility Treatments

Treatments		Above Ground Dry Matter (kg/ha)			(kg/ha)
		Rep.1	Rep.2	Rep.3	
		WTD1			
F1	I1	171.0	158.5	156.0	162.0
	I2	35.8	50.7	68.3	51.6
	I3	31.7	109.7	35.0	58.9
F2	I1	1264.0	1396.1	*	1330.1
	I2	1622.0	1438.0	*	1530.0
	I3	1054.5	1430.4	*	1242.5
F3	I1	1627.3	886.4	1612.9	1375.5
	I2	1386.9	1176.5	1142.5	1235.3
	I3	841.4	1080.7	*	961.1
		WTD2			
F1	I1	*	669.1	272.8	471.0
	I2	338.3	1245.5	807.9	797.2
	I3	173.2	119.8	103.5	132.2
F2	I1	*	2318.2	1097.5	1707.9
	I2	4480.5	3766.3	3011.7	3752.8
	I3	2392.8	4180.0	2976.9	3183.2
F3	I1	*	1120.1	1078.0	1099.1
	I2	3690.7	3569.9	4065.2	3775.3
	I3	4517.7	4237.5	3516.7	4090.6
		WTD3			
F1	I1	331.4	366.0	335.6	344.3
	I2	275.7	264.0	393.6	311.1
	I3	140.3	22.9	78.2	80.5
F2	I1	998.2	1140.9	580.2	906.4
	I2	2058.6	2977.6	3156.3	2730.8
	I3	1456.4	2659.9	1091.5	1735.9
F3	I1	1545.2	1661.0	1042.7	1416.3
	I2	4733.5	5123.0	3445.7	4434.1
	I3	4939.0	4136.3	4368.5	4481.3

Table A6 Root Weight of Sweet Corn under Different Water Table Depths, Irrigation and Fertility Treatments

Table A5 Dry Matter of Sweet Corn under Different Water Table Depths, Irrigation and Fertility Treatments. (cont.)

Treatments	Above Ground Dry Matter (kg/ha)			(kg.ha)
	Rep.1	Rep.2	Rep.3	
WTD4				
F1 I1	228.4	283.6	437.0	316.3
I2	571.7	157.8	1157.1	628.8
I3	321.7	309.0	866.5	499.1
F2 I1	965.0	1440.3	975.7	1127.0
I2	3148.1	2484.3	4561.2	3397.9
I3	3343.1	3525.9	3826.7	3565.2
F3 I1	1965.5	1385.1	2822.3	2057.6
I2	4006.4	4433.2	4679.5	4373.0
I3	4948.3	5050.2	3793.1	4597.2
WTD5				
F1 I1	141.2	19.7	10.3	57.1
I2	391.6	427.1	76.0	292.1
I3	537.8	681.7	44.6	421.4
F2 I1	210.4	212.8	72.4	165.2
I2	1253.7	2322.3	882.7	1486.2
I3	1780.6	1313.0	2489.4	1861.0
F3 I1	148.2	341.9	149.0	213.0
I2	1555.6	1447.3	967.5	1323.5
I3	4812.4	3118.8	1678.3	3203.2

* missing data

Table A6 Root Weight of Sweet Corn under Different Water Table Depths, Irrigation and Fertility Treatments

Treatments	Dry Root Weight (gm)		
	Rep.1	Rep.2	Rep.3
WTD1			
F1 I1	0.20	1.70	0.65
I2	0.55	0.40	0.35
I3	0.55	0.45	0.30
F2 I1	5.00	3.11	*
I2	6.90	3.60	*
I3	4.60	4.20	*
F3 I1	1.65	2.40	9.65
I2	3.90	2.80	4.10
I3	6.85	6.90	*
WTD2			
F1 I1	*	1.35	0.63
I2	1.00	3.90	5.90
I3	2.05	0.98	2.90
F2 I1	*	4.42	7.90
I2	4.40	2.75	9.10
I3	7.30	4.20	10.20
F3 I1	*	2.50	2.50
I2	10.40	14.30	8.50
I3	9.30	13.00	3.10
WTD			
F1 I1	1.00	0.90	1.29
I2	3.10	1.06	1.20
I3	1.45	0.65	0.40
F2 I1	2.10	1.62	3.20
I2	7.11	9.65	3.60
I3	8.60	9.90	7.70
F3 I1	2.75	2.40	2.80
I2	10.65	9.90	9.57
I3	8.20	13.30	9.60

Table A6 Root Weight of Sweet Corn under Different Water Table Depths, Irrigation and Fertility Treatments. (cont.)

Treatments		Dry Root Weight (gm)		
		Rep.1	Rep.2	Rep.3
		WTD4		
F1	I1	0.20	0.45	1.15
	I2	1.34	3.75	1.50
	I3	1.16	0.80	1.80
F2	I1	2.30	3.25	4.90
	I2	6.95	8.00	7.70
	I3	6.60	6.40	12.65
F3	I1	7.20	5.60	5.60
	I2	14.45	8.10	5.35
	I3	14.90	13.70	6.00
		WTD5		
F1	I1	1.10	0.55	0.35
	I2	2.35	1.70	0.50
	I3	2.10	1.85	0.37
F2	I1	1.50	0.45	0.60
	I2	5.60	9.40	1.95
	I3	5.60	3.90	1.40
F3	I1	0.70	1.30	1.20
	I2	14.30	4.60	3.10
	I3	5.00	8.80	4.81

* missing data

Note: Including 4 mm. of rainfall on Feb.10 and 2 mm. on Apr. 16

Table A7 (1) Total and Mean Soil Moisture Depletion for WTD1

Pe- riod	Date	Dura- tion	Soil Depletion depth, cm	Soil Moisture Depletion in mm.									
				F1I1	F1I2	F1I3	F2I1	F2I2	F2I3	F3I1	F3I2	F3I3	
1	Feb. 2 - Feb.11	10	15	13.0	12.0	12.0	13.0	13.0	13.0	13.0	11.0	12.0	12.0
2	Feb.12 - Feb.21	10	30	20.0	15.2	27.2	19.0	40.8	32.0	26.0	15.2	19.2	19.2
3	Feb.22 - Mar. 6	13	45	16.9	23.7	24.8	16.9	33.6	28.1	13.0	31.4	29.2	29.2
4	Mar. 7 - Mar.18	12	45	2.4	20.5	26.5	3.6	50.5	25.5	12.0	37.5	31.5	31.5
5	Mar.19 - Apr. 3	16	45	12.8	22.3	30.7	16.0	48.9	48.9	14.4	53.1	40.5	40.5
6	Apr. 4 - Ape.11	8	45	4.8	21.6	20.4	4.0	34.2	31.2	0.6	33.6	21.6	21.6
7	Apr.12 - Apr.18	7	45	7.7	21.0	25.5	11.9	24.0	28.5	0.0	27.0	25.0	25.0
Total Feb. 2 - Apr. 18		76		77.6	136.3	167.1	84.4	245.0	207.5	77.0	209.8	179.0	179.0
Mean (mm/day)				1.0	1.8	2.2	1.1	3.2	2.7	1.0	2.8	2.4	2.4
Mean Daily Soil Moisture Depletion in mm.													
1				1.3	1.2	1.2	1.3	1.3	1.3	1.1	1.2	1.2	1.2
2				2.0	1.5	2.7	1.9	4.1	3.2	2.6	1.5	1.9	1.9
3				1.3	1.8	1.9	1.3	2.6	2.2	1.0	2.4	2.2	2.2
4				0.2	1.7	2.2	0.3	4.2	2.1	1.0	3.1	2.6	2.6
5				0.8	1.4	1.9	1.0	3.1	3.1	0.9	3.3	2.5	2.5
6				0.6	2.7	2.6	0.5	4.3	3.9	0.07	4.2	2.7	2.7
7				1.1	3.0	3.6	1.7	3.4	4.1	0.0	3.9	3.6	3.6

Note: including 4 mm. of rainfall on Feb.10 and 2 mm. on Apr. 16

Table A7 (2) Total and Mean Soil Moisture Depletion for WTD2

Pe- riod	Date	Dura- tion	Soil depletion depth, cm	Soil Moisture Depletion in mm.								
				F1I1	F1I2	F1I3	F2I1	F2I2	F2I3	F3I1	F3I2	F3I3
1	Feb. 2 - Feb.11	10	15	23.0	26.0	22.0	20.0	24.0	22.0	25.0	23.0	23.0
2	Feb.12 - Feb.21	10	30	3.0	14.4	27.2	19.0	11.5	40.8	13.0	11.2	24.8
3	Feb.22 - Mar. 5	12	45	6.0	51.9	53.9	8.4	0.9	53.9	12.0	44.9	59.9
4	Mar. 6 - Mar.17	12	45	3.6	49.0	47.0	13.2	49.0	71.0	6.0	53.0	83.0
5	Mar.18 - Apr. 2	16	45	8.0	55.1	56.5	3.2	55.1	64.9	0.0	48.1	70.5
6	Apr. 3 - Apr.11	9	45	0.0	55.6	52.8	00.1	58.4	55.6	3.6	53.5	57.7
7	Apr.12 - Apr.17	6	45	0.0	34.7	37.1	0.0	31.9	31.1	0.0	27.9	39.1
Total Feb. 2 - Apr.17				43.6	286.7	296.5	63.9	280.8	339.3	59.6	261.6	358.0
Mean (mm/day)				0.6	3.8	4.0	0.9	3.7	4.5	0.8	3.5	4.8
Mean Daily Soil Moisture Depletion in mm.												
1				2.3	2.6	2.2	2.0	2.4	2.2	2.5	2.3	2.3
2				0.3	1.4	2.7	1.9	1.2	4.1	1.3	1.1	2.5
3				0.5	4.3	4.5	0.7	4.2	4.5	1.0	3.7	5.0
4				0.3	4.1	3.9	1.1	4.1	5.9	0.5	4.4	6.9
5				0.5	3.4	3.5	0.2	3.4	4.1	0.0	3.0	4.4
6				0.0	6.2	5.9	0.01	6.5	6.2	0.4	5.9	6.4
7				0.0	5.8	6.2	0.0	5.3	5.2	0.0	4.7	6.5

Note: including 4 mm. of rainfall on Feb.10 and 2 mm. on Apr. 16

Tabel A7 (3) Total and Mean Soil Moisture Depletion for WTD3

Pe- riod	Date	Dura- tion	Soil depletion depth, cm	Soil Moisture Depletion in mm.										
				F1I1	F1I2	F1I3	F2I1	F2I2	F2I3	F3I1	F3I2	F3I3		
1	Feb. 2 - Feb.11	10	15	26.0	22.0	21.0	26.0	26.0	24.0	24.0	26.0	24.0	24.0	24.0
2	Feb.12 - Feb.21	10	30	12.0	25.6	33.6	21.0	24.0	24.0	28.8	16.0	24.0	24.0	37.6
3	Feb.22 - Mar. 5	12	45	8.4	40.9	52.9	13.2	37.9	47.9	12.0	12.0	46.9	59.9	59.9
4	Mar. 6 - Mar.16	11	45	6.6	33.0	48.3	5.5	42.9	62.7	7.7	7.7	43.8	58.2	58.2
5	Mar.17 - Apr. 1	16	45	9.6	51.0	55.2	8.0	49.6	63.6	8.0	8.0	53.4	67.8	67.8
6	Apr. 2 - Apr.10	9	45	0.0	51.4	43.0	1.8	47.2	55.6	0.0	0.0	49.3	54.9	54.9
7	Apr.11 - Apr.17	7	45	2.1	34.7	35.7	2.8	27.7	37.2	2.8	2.8	35.7	31.2	31.2
Total Feb. 2 - Apr.17				64.7	258.6	289.7	78.3	255.3	319.8	72.5	277.1	333.6	333.6	333.6
Mean (mm/day)				0.9	3.4	3.9	1.0	3.4	4.3	1.0	3.7	4.4	4.4	4.4
Mean Daily Soil Moisture Depletion in mm.														
1				2.6	2.2	2.2	2.6	2.6	2.4	2.6	2.6	2.4	2.4	2.4
2				1.2	2.6	3.4	2.1	2.4	2.9	1.6	1.6	2.4	2.4	3.8
3				0.7	3.4	4.4	1.1	3.2	4.0	1.0	1.0	3.9	3.9	5.0
4				0.6	3.0	4.4	0.5	3.9	5.7	0.7	0.7	4.0	4.0	5.3
5				0.6	3.2	3.5	0.5	3.1	4.0	0.5	0.5	3.3	3.3	4.2
6				0.0	5.7	4.8	0.2	5.2	6.2	0.0	0.0	5.5	5.5	6.1
7				0.3	5.0	5.1	0.4	4.0	5.3	0.4	0.4	5.1	5.1	4.5

Note: including 4 mm. of rainfall on Feb. 10 and 2 mm. on Apr. 16

Table A7 (4) Total and Mean Soil Moisture Depletion for WTD4

Pe- riod	Date	Dura- tion	Soil depletion depth, cm	Soil Moisture Depletion in mm.									
				F1I1	F1I2	F1I3	F2I1	F2I2	F2I3	F3I1	F3I2	F3I3	
1	Feb. 2 - Feb.11	10	15	31.0	32.0	29.0	27.0	26.0	26.0	29.0	31.0	31.0	
2	Feb.12 - Feb.21	10	30	18.0	40.8	35.2	18.0	32.8	33.6	4.0	26.4	29.6	
3	Feb.22 - Mar. 4	11	45	5.5	32.0	41.9	15.4	31.1	42.8	11.0	38.3	44.6	
4	Mar. 5 - Mar.16	12	45	12.0	42.3	42.3	18.0	49.3	54.3	15.6	55.3	59.3	
5	Mar.17 - Mar.31	15	45	24.0	52.3	54.9	16.5	48.4	57.5	13.5	52.3	60.1	
6	Apr. 1 - Apr.10	10	45	0.0	41.2	44.4	3.0	40.4	50.0	3.0	38.0	50.8	
7	Apr.11 - Apr.17	7	45	0.0	33.2	34.2	12.6	24.7	30.2	2.1	26.7	33.7	
Total Feb. 2 - Apr. 17				90.5	273.8	281.9	110.6	252.7	294.4	78.2	268.0	309.1	
Mean (mm./day)				1.2	3.7	3.8	1.5	3.4	3.9	1.0	3.6	4.1	
Mean Daily Soil Moisture Depletion in mm.													
1				3.1	3.2	2.9	2.7	2.6	2.6	2.9	3.1	3.1	
2				1.8	4.1	3.5	1.5	3.3	3.4	0.4	2.6	3.0	
3				0.5	2.9	3.8	1.4	2.8	3.9	1.0	3.5	4.1	
4				1.0	3.5	3.5	1.5	4.1	4.5	1.3	4.6	4.9	
5				1.6	3.5	3.7	1.1	3.2	3.8	0.9	3.5	4.0	
6				0.0	4.1	4.4	0.3	4.0	5.0	0.3	3.8	5.1	
7				0.0	4.7	4.9	1.8	3.5	4.3	0.3	3.8	4.8	

Note: including 4 mm. of rainfall on Feb. 10 and 2 mm. on Apr. 16

Table A7 (5) Total and Mean Soil Moisture Depletion for WTD5

Pe- riod	Date	Dura- tion	Soil depletion depth, cm	Soil Moisture Depletion in mm.												
				F1I1	F1I2	F1I3	F2I1	F2I2	F2I3	F3I1	F3I2	F3I3				
1	Feb. 2 - Feb. 12	11	15	34.1	34.1	34.1	35.2	35.2	34.1	34.1	34.1	34.1	34.1	34.1	34.1	
2	Feb. 13 - Feb. 22	10	30	4.0	20.8	18.4	9.0	26.4	28.8	28.8	10.0	29.6	29.6	29.6	29.6	
3	Feb. 23 - Mar. 6	12	45	7.2	30.9	37.9	4.8	28.9	43.9	43.9	4.0	37.9	43.9	43.9	43.9	
4	Mar. 7 - Mar. 17	11	45	1.1	41.5	46.9	3.3	41.5	57.7	57.7	3.3	42.4	58.6	58.6	58.6	
5	Mar. 18 - Mar. 30	13	45	3.9	45.6	43.4	2.6	40.1	62.1	62.1	1.3	34.6	51.1	51.1	51.1	
6	Mar. 31 - Apr. 9	10	45	2.0	48.5	49.3	0.2	40.5	56.5	56.5	0.1	43.7	58.9	58.9	58.9	
7	Apr. 10 - Apr. 18	9	45	4.5	30.4	28.3	2.7	20.6	33.2	33.2	2.7	29.0	33.9	33.9	33.9	
Total Feb. 2 - Apr. 18				56.8	251.8	258.3	57.8	233.2	316.3	316.3	55.5	251.3	310.1	310.1	310.1	310.1
Mean (mm./day)				0.7	3.3	3.4	0.8	3.1	4.2	4.2	0.7	3.3	4.1	4.1	4.1	4.1
Mean Daily Soil Moisture Depletion in mm.																
1				3.1	3.1	3.1	3.2	3.2	3.1	3.1	3.1	3.1	3.1	3.1	3.1	
2				0.4	2.1	1.8	0.9	2.6	2.9	2.9	1.0	3.0	3.0	3.0	3.0	
3				0.6	2.6	3.2	0.4	2.4	3.7	3.7	0.4	3.2	3.7	3.7	3.7	
4				0.1	3.8	4.3	0.3	3.8	5.2	5.2	0.3	3.9	5.3	5.3	5.3	
5				0.3	3.5	3.3	0.2	3.1	4.8	4.8	0.1	2.7	3.9	3.9	3.9	
6				0.2	4.9	4.9	0.02	4.1	5.7	5.7	0.01	4.4	5.9	5.9	5.9	
7				0.5	3.4	3.1	0.3	2.3	3.7	3.7	0.3	3.2	3.8	3.8	3.8	

Note: including 4 mm. of rainfall on Feb. 10 and 2 mm. on Apr. 16.

Table A8 (1) Total and Mean Soil Moisture Depletion for WTD2

Pe- riod	Date	Dura- tion	Soil depletion depth, cm	Soil Moisture Depletion in mm.								
				F1I1	F1I2	F1I3	F2I1	F2I2	F2I3	F3I1	F3I2	F3I3
1	Feb. 2 - Feb.11	10	15	23.0	26.0	22.0	20.0	24.0	22.0	25.0	23.0	23.0
2	Feb.12 - Feb.21	10	45	5.0	11.2	32.8	27.0	11.2	49.6	16.0	11.2	28.0
3	Feb.22 - Mar. 5	12	60	10.8	58.9	61.9	12.0	59.9	63.9	18.0	48.9	63.9
4	Mar. 6 - Mar.17	12	75	3.6	49.6	47.3	14.4	50.9	77.7	4.8	83.7	83.7
5	Mar.18 - Apr. 2	16	75	11.2	58.9	61.8	8.0	68.4	76.6	3.2	48.5	76.9
6	Apr. 3 - Apr.11	9	75	0.9	59.5	57.9	1.8	66.5	62.2	6.3	57.7	61.3
7	Apr.12 - Apr.17	6	75	0.0	43.6	38.1	0.0	33.0	33.5	0.0	29.8	41.0
Total				54.5	307.8	321.8	83.2	313.9	385.6	73.3	272.2	377.9
Mean (mm./day)				0.7	4.1	4.3	1.1	4.2	5.1	1.0	3.6	5.0
Mean Daily Soil Moisture Depletion in mm.												
1				2.3	2.6	2.2	2.0	2.4	2.2	2.5	2.3	2.3
2				0.5	1.1	3.3	2.7	1.1	5.0	1.6	1.1	2.8
3				0.9	4.9	5.2	1.0	5.0	5.3	1.5	4.1	5.3
4				0.3	4.1	3.9	1.2	4.2	6.5	0.4	4.4	7.0
5				0.7	3.7	3.9	0.5	4.3	4.8	0.2	3.0	4.8
6				0.1	6.6	6.4	0.2	7.4	6.9	0.7	6.4	6.8
7				0.0	7.3	6.3	0.0	5.5	5.6	0.0	5.0	6.8

Note: Including 4 mm. of rainfall on Feb. 10 and 2 mm. on Apr. 16

Table A8 (2) Total and Mean Soil Moisture Depletion for WTD3

Pe- riod	Date	Dura- tion	Soil depletion depth, cm	Soil Moisture Depletion in mm.											
				F1I1	F1I2	F1I3	F2I1	F2I2	F2I3	F3I1	F3I2	F3I3			
1	Feb. 2 - Feb.11	10	15	26.0	22.0	21.0	26.0	26.0	26.0	24.0	26.0	24.0	24.0	24.0	24.0
2	Feb.12 - Feb.21	10	45	19.0	36.0	38.4	29.0	34.4	34.4	34.4	23.0	26.4	26.4	26.4	46.4
3	Feb.22 - Mar. 5	12	75	15.6	50.9	64.9	21.6	50.9	50.9	55.9	21.6	54.9	54.9	54.9	70.9
4	Mar. 6 - Mar.16	11	90	12.1	35.7	54.5	19.8	46.1	46.1	62.2	14.3	46.8	46.8	46.8	64.8
5	Mar.17 - Apr. 1	16	90	14.4	43.0	63.0	17.6	61.1	61.1	68.3	22.4	68.9	68.9	68.9	80.2
6	Apr. 2 - Apr.10	9	90	3.6	63.7	50.8	10.8	56.5	56.5	58.9	4.5	61.2	61.2	61.2	66.3
7	Apr.11 - Apr.17	7	90	6.3	40.0	42.2	9.1	31.8	31.8	38.0	8.4	41.5	41.5	41.5	29.2
Total	Feb. 2 - Apr. 17	75		97.0	291.3	334.9	133.9	306.8	306.8	341.7	120.2	328.7	328.7	328.7	381.8
Mean	(mm./day)			1.3	3.9	4.5	1.8	4.1	4.1	4.6	1.6	4.3	4.3	4.3	5.1
				Mean Daily Soil Moisture Depletion in mm.											
1				2.6	2.2	2.1	2.6	2.6	2.6	2.4	2.6	2.4	2.4	2.4	2.4
2				1.9	3.6	3.8	2.9	3.4	3.4	3.4	2.3	2.6	2.6	2.6	4.6
3				1.3	4.2	5.4	1.8	4.2	4.2	4.7	1.8	4.6	4.6	4.6	5.9
4				1.1	3.2	5.0	1.8	4.2	4.2	5.7	1.3	4.3	4.3	4.3	5.9
5				0.9	2.7	3.9	1.1	3.8	3.8	4.3	1.4	4.3	4.3	4.3	5.0
6				0.4	7.1	5.6	1.2	6.3	6.3	6.5	0.5	6.8	6.8	6.8	7.4
7				0.9	5.7	6.0	1.3	4.5	4.5	5.4	1.2	5.9	5.9	5.9	4.2

Note: including 4 mm. of rainfall on Feb. 10 and 2 mm. on Apr. 16

Table A8 (3) Total and Mean Soil Moisture Depletion for WTD4

Pe- riod	Date	Dura- tion	Soil depletion depth, cm	Soil Moisture Depletion in mm.								
				F1I1	F1I2	F1I3	F2I1	F2I2	F2I3	F3I1	F3I2	F3I3
1	Feb. 2 - Feb.11	10	15	31.0	32.0	29.0	27.0	26.0	26.0	29.0	31.0	31.0
2	Feb.12 - Feb.21	10	60	41.0	57.6	57.6	21.0	48.8	54.4	11.0	32.8	36.8
3	Feb.22 - Mar. 4	11	120	14.3	45.7	58.3	0.0	14.9	14.9	18.7	51.4	56.7
4	Mar. 5 - Mar.16	12	120	25.2	50.8	54.9	37.2	61.1	72.0	42.0	75.2	74.5
5	Mar.17 - Mar.31	15	120	63.0	82.0	93.2	49.5	82.8	99.6	43.5	84.4	98.9
6	Apr. 1 - Apr.10	10	120	17.0	47.9	59.4	6.0	48.4	63.0	7.0	42.5	66.3
7	Apr.11 - Apr.17	7	120	0.0	33.6	46.4	0.0	15.7	15.7	4.9	26.0	41.0
Total Feb. 2 - Apr. 17				191.5	349.6	398.9	140.7	297.7	345.7	149.1	343.3	405.2
Mean (mm./day)				2.6	4.7	5.3	1.9	4.0	4.6	2.0	4.6	5.4
Mean Daily Soil Moisture Depletion in mm.												
1				3.1	3.2	2.9	2.7	2.6	2.6	2.9	3.1	3.1
2				4.1	5.8	5.8	2.1	4.9	5.4	1.1	3.3	3.7
3				1.3	4.2	5.3	0.0	1.4	1.4	1.7	4.7	5.2
4				2.1	4.2	4.6	3.1	5.1	6.0	3.5	6.3	6.2
5				4.2	5.5	6.2	3.3	5.5	6.6	2.9	5.6	6.6
6				1.7	4.8	5.9	0.6	4.8	6.3	0.7	4.3	6.6
7				0.0	4.8	6.6	0.0	2.2	2.2	0.7	3.7	5.9

Note: including 4 mm. of rainfall on Feb. 10 and 2 mm. on Apr.16

Table A8 (4) Total and Mean Soil Moisture Depletion for WTD5

Pe- riod	Date	Dura- tion	Soil depletion depth, cm	Soil Moisture Dapl													
				F1I1	F1I2	F1I3	F2I1	F2I2	F2I3	F3I1	F3I2	F3I3					
1	Feb. 2 - Feb.12	11	15	34.1	34.1	34.1	35.2	35.2	34.1	34.1	34.1	34.1	34.1	34.1	34.1	34.1	
2	Feb.13 - Feb.22	10	60	0.0	27.2	25.6	4.0	46.4	45.6	44.8	44.8	10.0	44.8	44.8	47.2	47.2	
3	Feb.23 - Mar. 6	12	120	14.4	17.1	67.1	12.0	33.9	62.7	36.7	36.7	9.6	36.7	36.7	62.1	62.1	
4	Mar. 7 - Mar.17	11	120	2.2	42.1	75.8	15.4	54.4	91.9	58.5	58.5	5.5	58.5	58.5	97.1	97.1	
5	Mar.18 - Mar.30	13	120	3.9	60.8	73.8	7.8	51.5	95.2	55.8	55.8	5.2	55.8	55.8	100.7	100.7	
6	Mar.31 - Apr. 9	10	120	7.0	58.7	88.7	5.0	46.3	57.2	55.4	55.4	1.0	55.4	55.4	100.9	100.9	
7	Apr.10 - Apr.18	9	120	0.9	37.3	50.4	5.4	29.1	60.1	34.8	34.8	5.4	34.8	34.8	61.4	61.4	
Total Feb. 2 - Apr. 18				62.5	279.4	415.5	84.4	296.9	446.9	320.2	320.2	70.8	320.2	320.2	503.4	503.4	
Mean (mm./day)				0.8	3.7	5.5	1.1	3.9	5.9	4.2	0.9	4.2	4.2	6.6	6.6		
												Mean Daily Soil Moisture Depletion in mm.					
1				3.1	3.1	3.1	3.2	3.2	3.1	3.1	3.1	3.1	3.1	3.1	3.1	3.1	
2				0.0	2.7	2.6	0.4	4.6	4.6	4.5	4.5	1.0	4.5	4.5	4.7	4.7	
3				1.2	1.4	5.6	1.0	2.8	5.2	3.1	3.1	0.8	3.1	3.1	5.2	5.2	
4				0.2	3.8	6.9	1.4	4.9	8.4	5.3	5.3	0.5	5.3	5.3	8.8	8.8	
5				0.3	4.7	5.7	0.6	4.0	7.3	4.3	4.3	0.4	4.3	4.3	7.7	7.7	
6				0.7	5.9	8.9	0.5	4.6	5.7	5.5	5.5	0.1	5.5	5.5	10.1	10.1	
7				0.1	4.1	5.6	0.6	3.2	6.7	3.9	3.9	0.6	3.9	3.9	6.8	6.8	

Note: including 4 mm. of rainfall on Feb. 10 and 2 mm. on Apr. 16

Table A9 Estimated ETo and ETc from Epan (class A) by Using Pan Coefficient (Kp) and Crop Coefficient (Kc) Recommended by FAO 1/

Date	Mean RH in % <u>2/</u>	Wind Velocity km/day <u>2/</u>	Kp case A <u>3/</u>	Epan mm.	ETo mm.	Kc Sweet corn	ETc mm.
Feb. 1	77.5	5.61	0.85	5.78	4.91	0.35	1.72
2	67.5	4.06	0.75	6.51	4.88	0.35	1.71
3	65.0	2.69	0.75	5.56	4.17	0.35	1.46
4	65.0	3.60	0.75	5.42	4.07	0.35	1.42
5	65.0	4.50	0.75	5.54	4.16	0.35	1.47
6	67.5	2.79	0.75	6.32	4.74	0.35	1.66
7	67.5	2.26	0.75	5.99	4.49	0.35	1.57
8	67.5	3.11	0.75	5.78	4.34	0.35	1.52
9	67.5	3.61	0.75	5.28	3.96	0.35	1.39
10	57.5	1.96	0.75	5.12	3.84	0.35	1.34
11	67.5	1.66	0.75	5.21	3.91	0.35	1.37
12	62.5	3.83	0.75	6.83	5.12	0.35	1.79
13	65.0	2.97	0.75	5.77	4.33	0.35	1.52
14	62.5	2.60	0.75	5.41	4.06	0.35	1.42
15	67.5	2.40	0.75	5.59	4.19	0.35	1.47
16	65.0	2.18	0.75	5.61	4.21	0.35	1.47
17	65.0	1.77	0.75	5.78	4.34	0.35	1.52
18	72.5	3.09	0.85	4.98	4.23	0.35	1.48
19	67.5	3.83	0.75	5.52	4.14	0.35	1.45
20	66.0	2.19	0.75	6.62	4.97	0.35	1.74
21	59.0	3.39	0.75	6.67	5.00	0.35	1.75
22	60.0	2.60	0.75	7.56	5.67	0.35	1.98
23	65.0	1.60	0.75	7.23	5.42	0.39	2.11
24	60.0	2.06	0.75	7.69	5.77	0.43	2.48
25	70.0	2.96	0.75	6.70	5.03	0.47	2.36
26	73.5	4.41	0.85	6.79	5.77	0.51	2.94
27	60.5	2.41	0.75	6.97	5.23	0.55	2.88
28	59.0	3.02	0.75	6.01	4.51	0.59	2.66
Mar. 1	70.0	2.72	0.75	6.68	5.01	0.63	3.16
2	70.0	3.11	0.75	6.10	4.58	0.67	3.07
3	65.0	4.24	0.75	7.33	5.50	0.71	3.91
4	64.0	3.56	0.75	5.24	3.93	0.75	2.95
5	63.5	3.50	0.75	6.10	4.58	0.79	3.62
6	67.5	5.43	0.75	7.15	5.36	0.83	4.45
7	65.0	5.21	0.75	7.88	5.91	0.87	5.14
8	62.5	3.99	0.75	6.66	5.00	0.91	4.55
9	60.0	3.63	0.75	7.55	5.66	0.95	5.38
10	54.5	2.73	0.75	7.59	5.69	0.99	5.63
11	57.5	2.31	0.75	6.82	5.12	1.03	5.27
12	60.0	4.55	0.75	6.94	5.21	1.07	5.57
13	60.0	3.44	0.75	7.45	5.59	1.11	6.20
14	65.0	2.93	0.75	8.05	6.04	1.15	6.95
15	62.5	3.82	0.75	8.23	3.92	1.15	4.51

Table A9 (continued)

Date	Mean RH in % <u>2/</u>	Wind Velocity km/day <u>2/</u>	Kp Case A <u>3/</u>	Epan mm.	ETo mm.	Kc Sweet corn	ETc mm.
Mar. 16	70.0	2.48	0.75	7.66	5.75	1.15	6.61
17	72.5	5.64	0.85	7.60	6.46	1.15	7.43
18	72.5	2.81	0.85	6.98	5.93	1.15	6.82
19	60.0	5.95	0.75	8.91	6.68	1.15	7.68
20	60.0	4.07	0.75	6.37	4.78	1.15	5.50
21	61.0	2.26	0.75	7.92	5.94	1.15	6.83
22	66.0	2.02	0.75	7.76	5.82	1.15	6.69
23	71.0	3.06	0.85	6.47	5.50	1.15	6.33
24	67.5	4.26	0.75	7.11	5.33	1.15	6.13
25	62.5	3.09	0.75	6.16	4.62	1.15	5.13
26	67.5	2.36	0.75	5.84	4.38	1.15	5.04
27	64.0	2.67	0.75	8.08	6.06	1.15	6.97
28	57.5	5.00	0.75	9.08	6.81	1.15	7.83
29	62.5	3.55	0.75	7.54	5.66	1.15	6.51
30	72.5	4.00	0.85	9.23	7.85	1.15	9.03
31	65.0	4.37	0.75	10.63	7.97	1.15	9.17
Apr. 1	63.5	4.02	0.75	9.06	6.80	1.15	7.82
2	65.0	3.50	0.75	8.18	6.14	1.15	7.06
3	60.0	2.18	0.75	8.24	6.18	1.15	7.11
4	69.0	2.64	0.75	8.19	6.14	1.15	7.06
5	72.5	3.11	0.85	7.40	6.29	1.15	7.23
6	65.0	3.96	0.75	9.12	6.84	1.15	7.87
7	67.5	5.83	0.75	8.71	6.53	1.15	7.51
8	60.5	3.07	0.75	8.03	6.02	1.15	6.92
9	61.0	3.86	0.75	8.50	6.38	1.15	7.34
10	60.0	3.62	0.75	2.72	2.04	1.15	2.35
11	70.0	2.43	0.75	6.70	5.03	1.14	5.73
12	64.0	2.97	0.75	9.02	6.77	1.13	7.65
13	66.0	2.82	0.75	5.47	4.85	1.11	5.38
14	71.0	3.60	0.85	8.84	7.51	1.11	8.34
15	71.0	3.06	0.85	7.45	6.33	1.09	6.90
16	73.0	3.92	0.85	3.56	3.03	1.08	3.27
17	66.0	3.60	0.75	6.41	4.81	1.06	5.10
18	72.5	3.06	0.85	5.21	4.43	1.05	4.65
Total	5033.0	257.17	58.95	531.15	404.22	62.92	343.28
Mean	65.36	3.34	0.76	6.90	5.25	0.82	4.46

- 1/ DOORENBOS, J., AND PRUITT, W.O. (1977), Crop Water Requirements, FAO Irrigation and Drainage Paper, No. 24, pp. 30-41.
 2/ Data from the station of Kalasin Pilot Farm Project, about 1 km. from experimental site.
 3/ Case A (short green cropped area 10 m.)

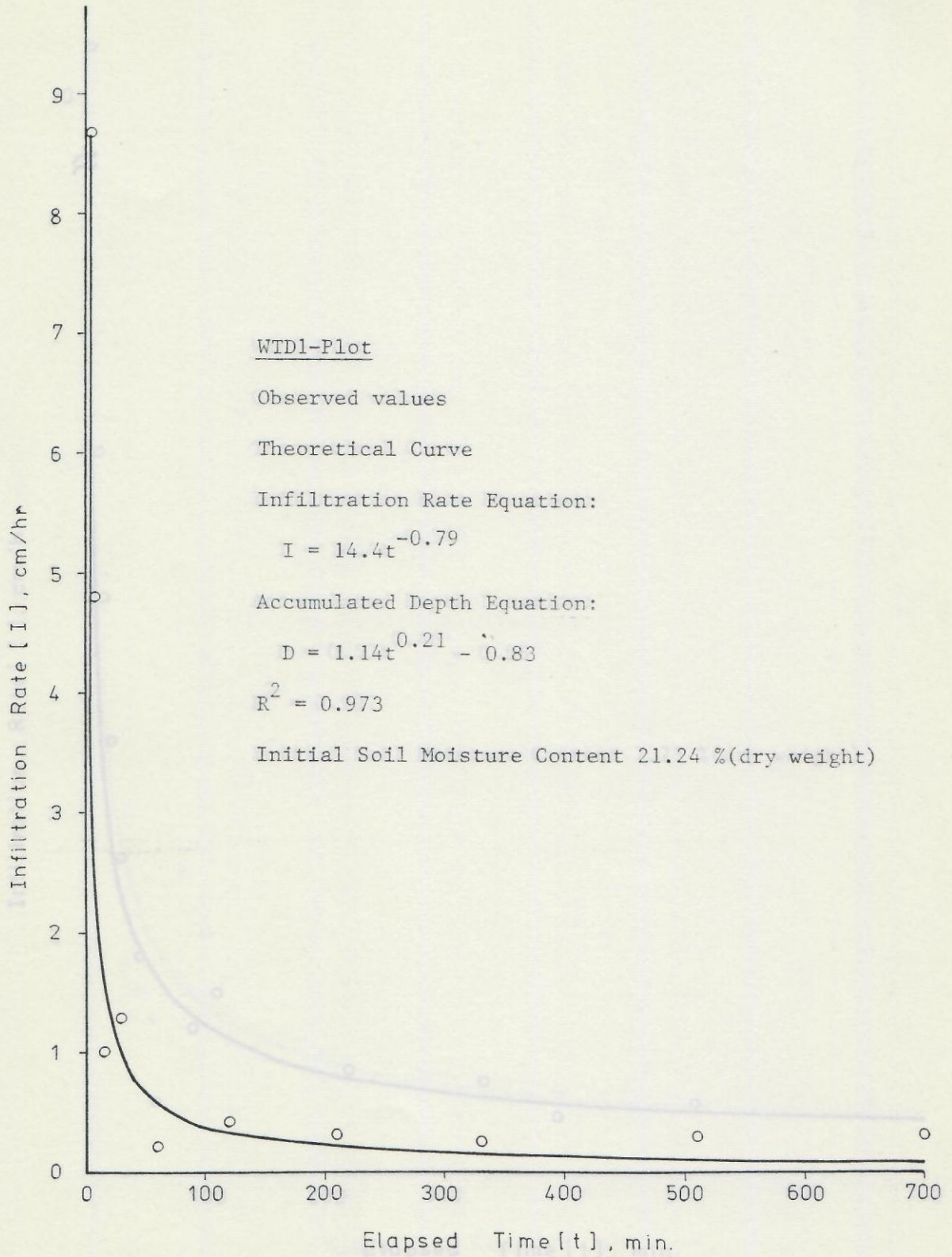

Fig A1(1) Infiltration Rate Curve

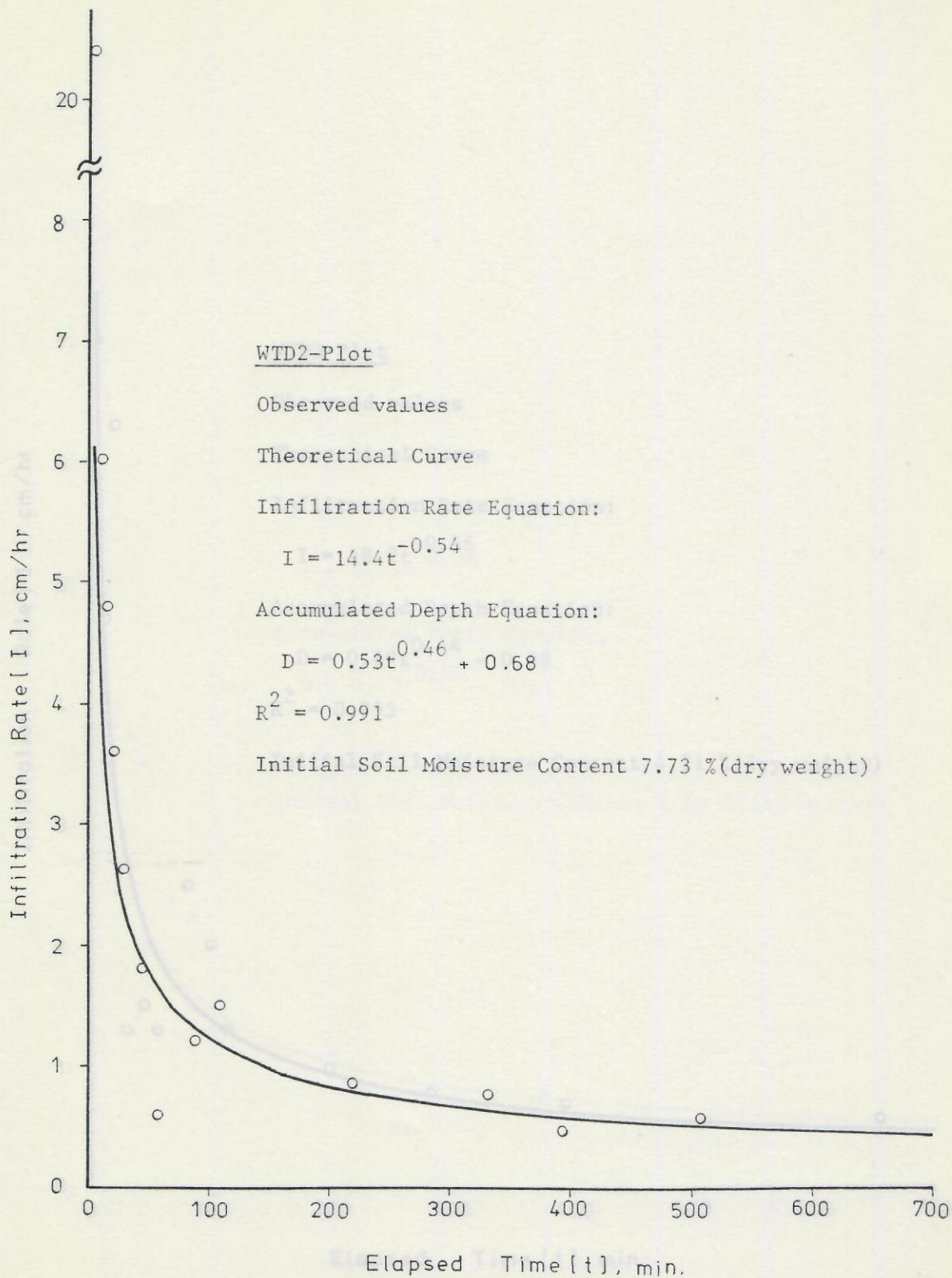

Fig A1(2) Infiltration Rate Curve

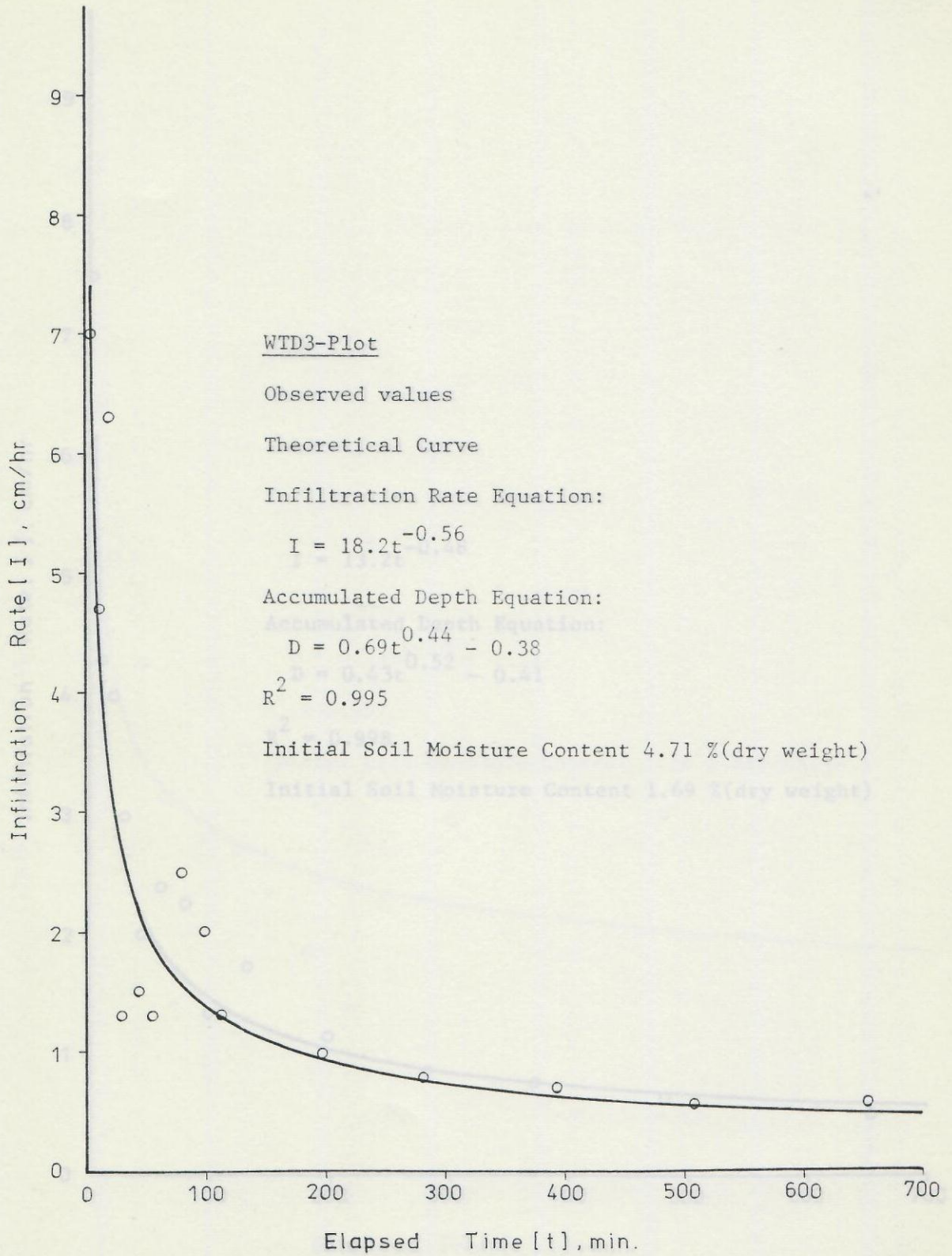

Fig A1(3) Infiltration Rate Curve

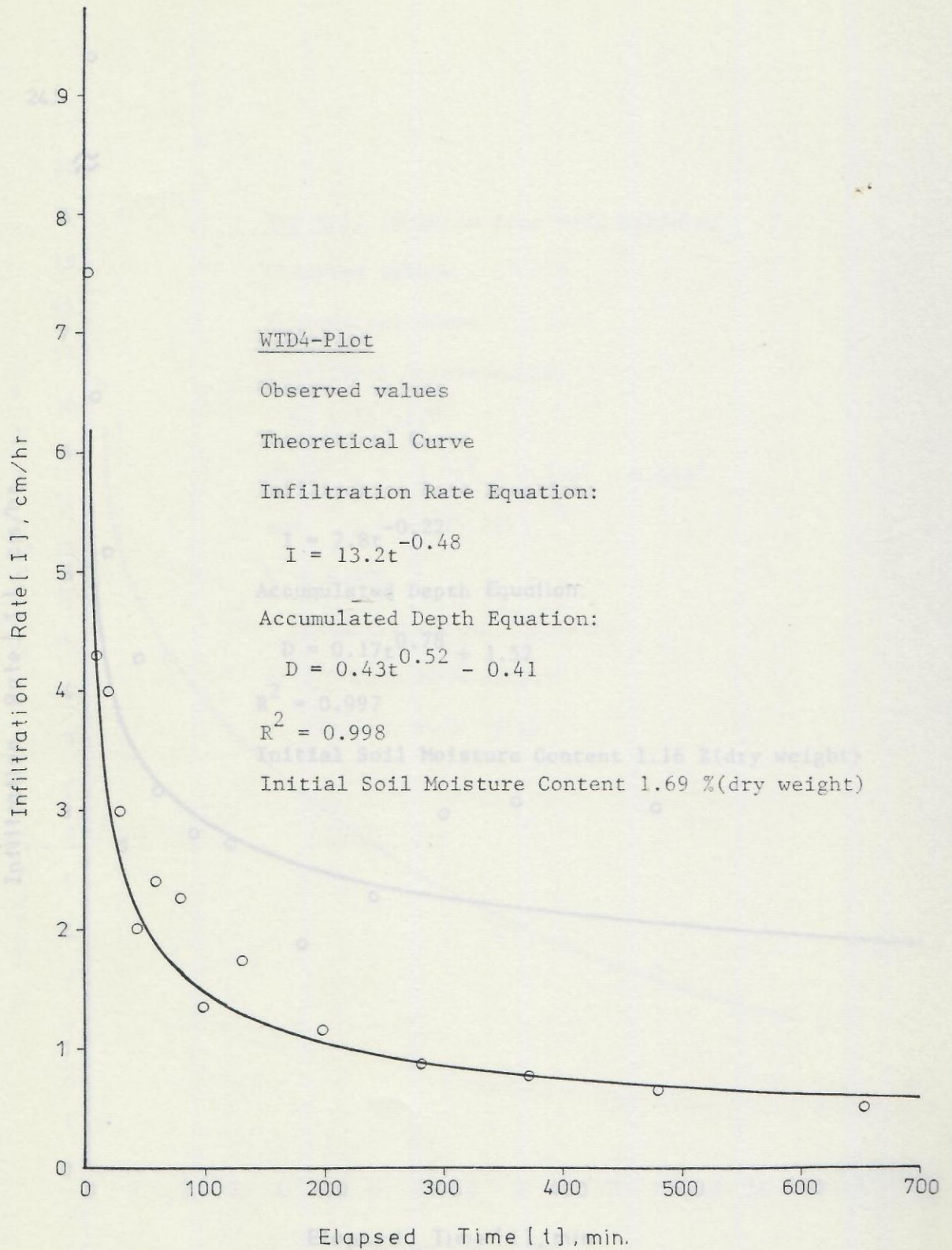

Fig A1(4) Infiltration Rate Curve

Appendix

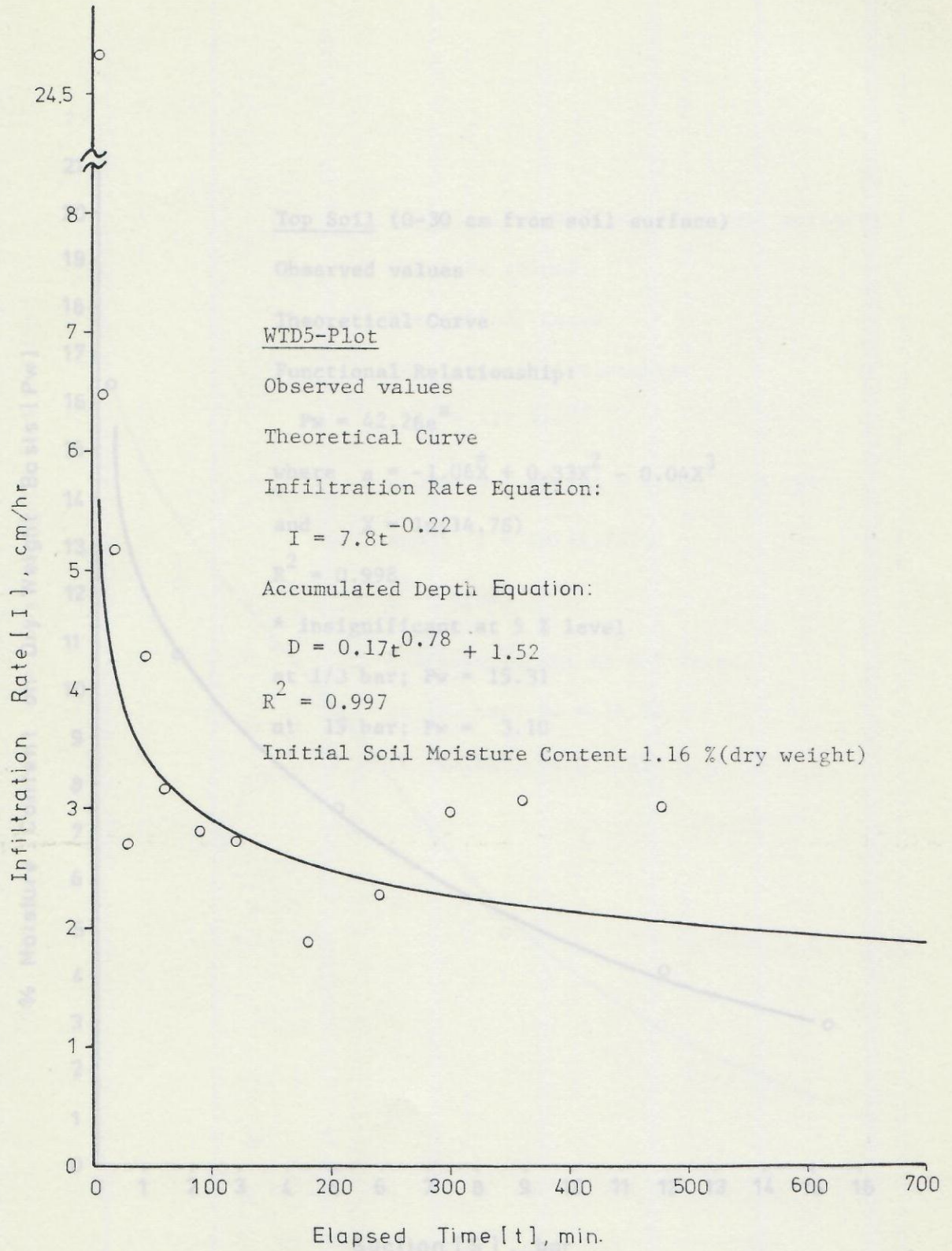

Fig A1(5) Infiltration Rate Curve

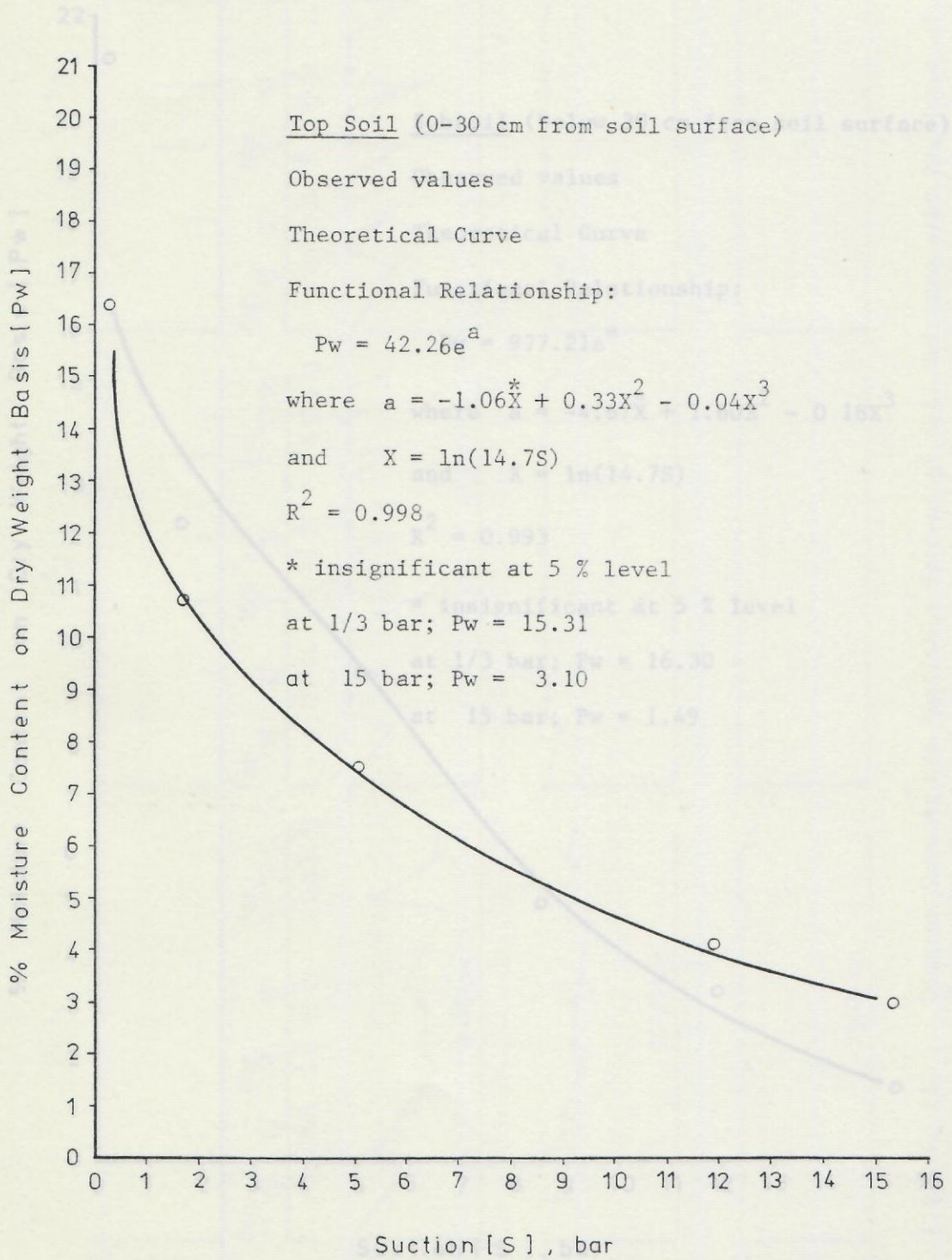

Fig A2(1) Soil Moisture Characteristic Curve

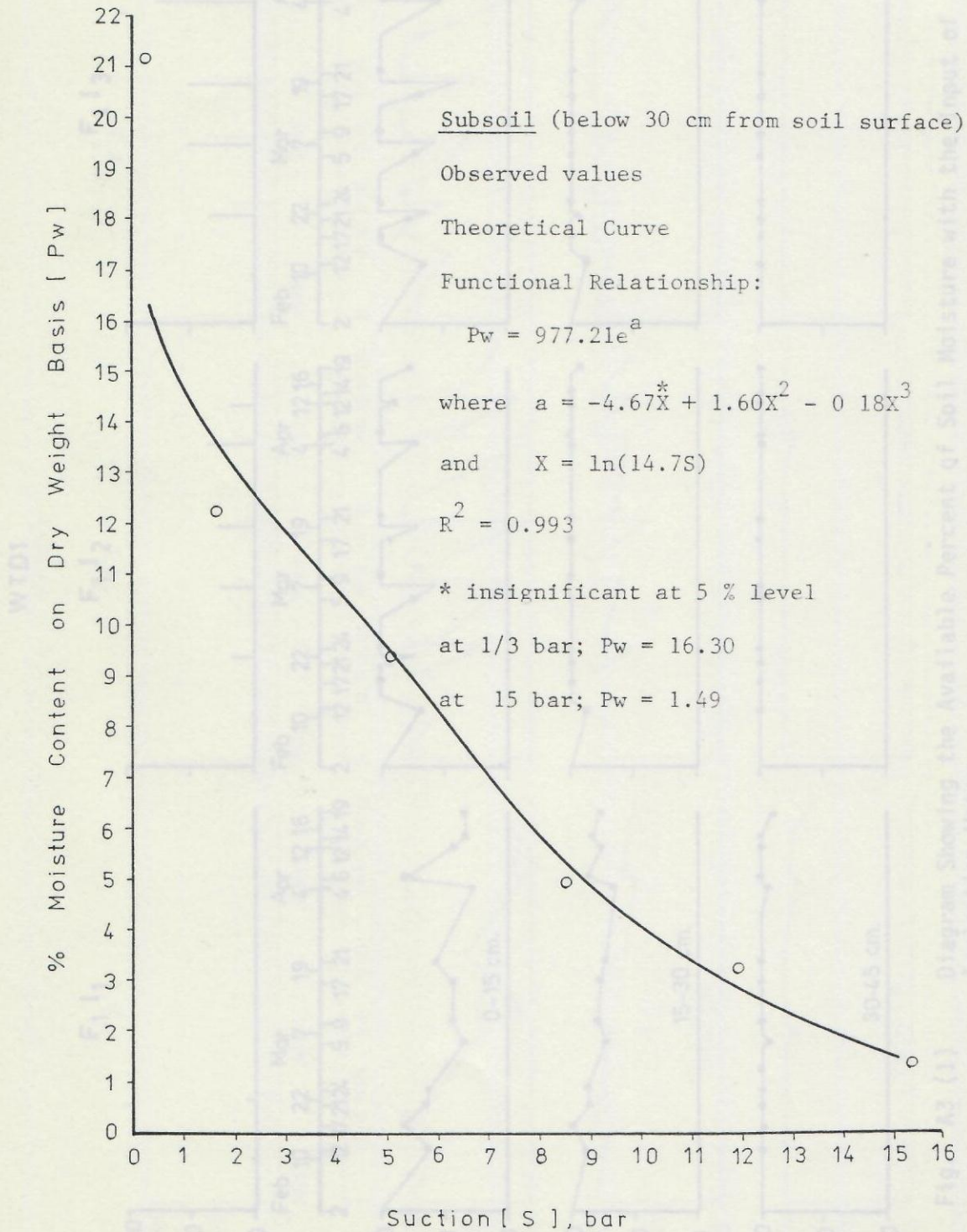

Fig A2(2) Soil Moisture Characteristic Curve

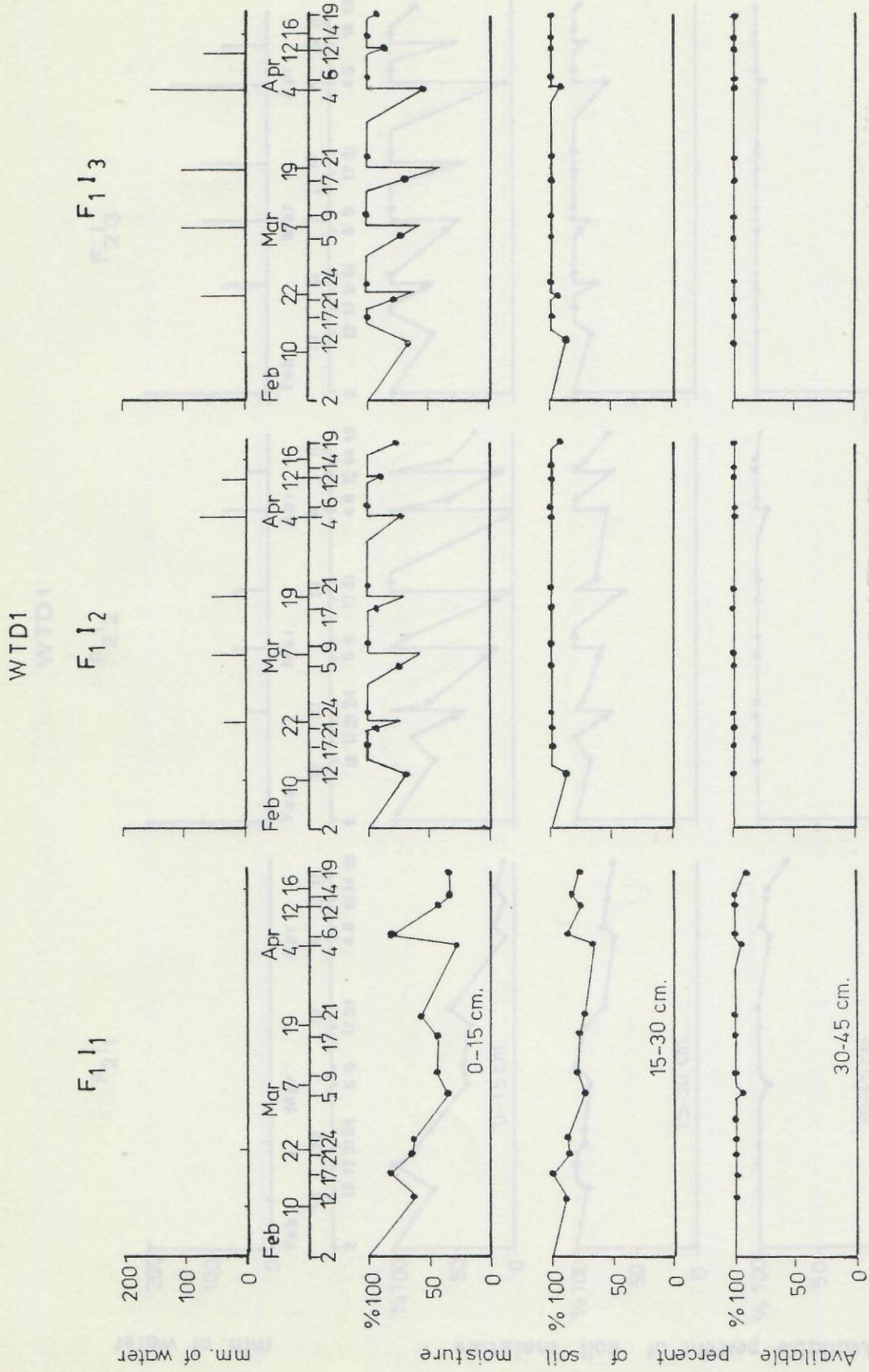

Fig. A3 (1) Diagram Showing the Available Percent of Soil Moisture with the Input of Irrigation Water.

WTD 1

F₂I₂

F₂I₁

F₂I₃

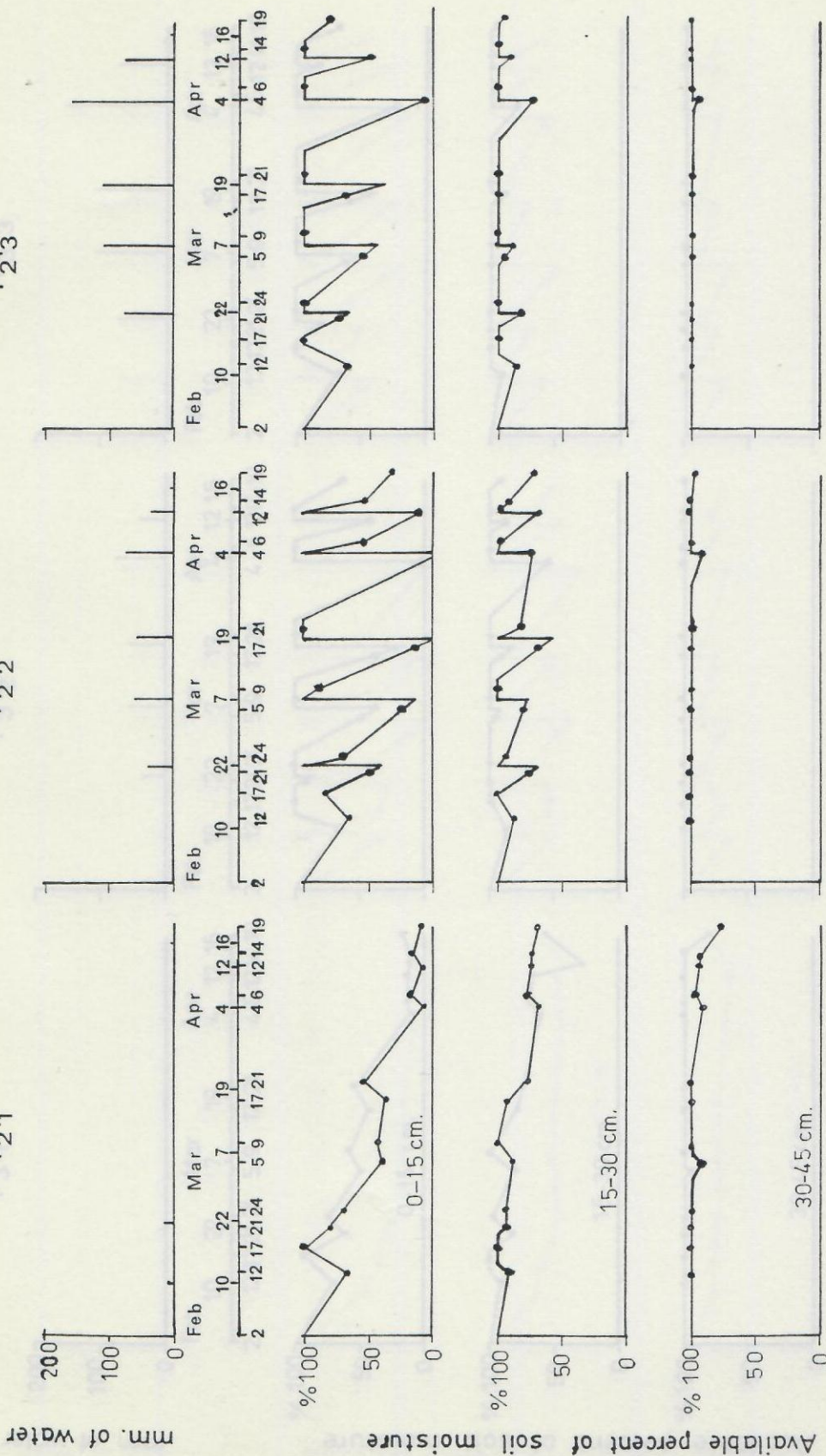

Fig. A3 (2) Diagram Showing the Available Percent of Soil Moisture with the Input of Irrigation Water (cont.)

WTD1

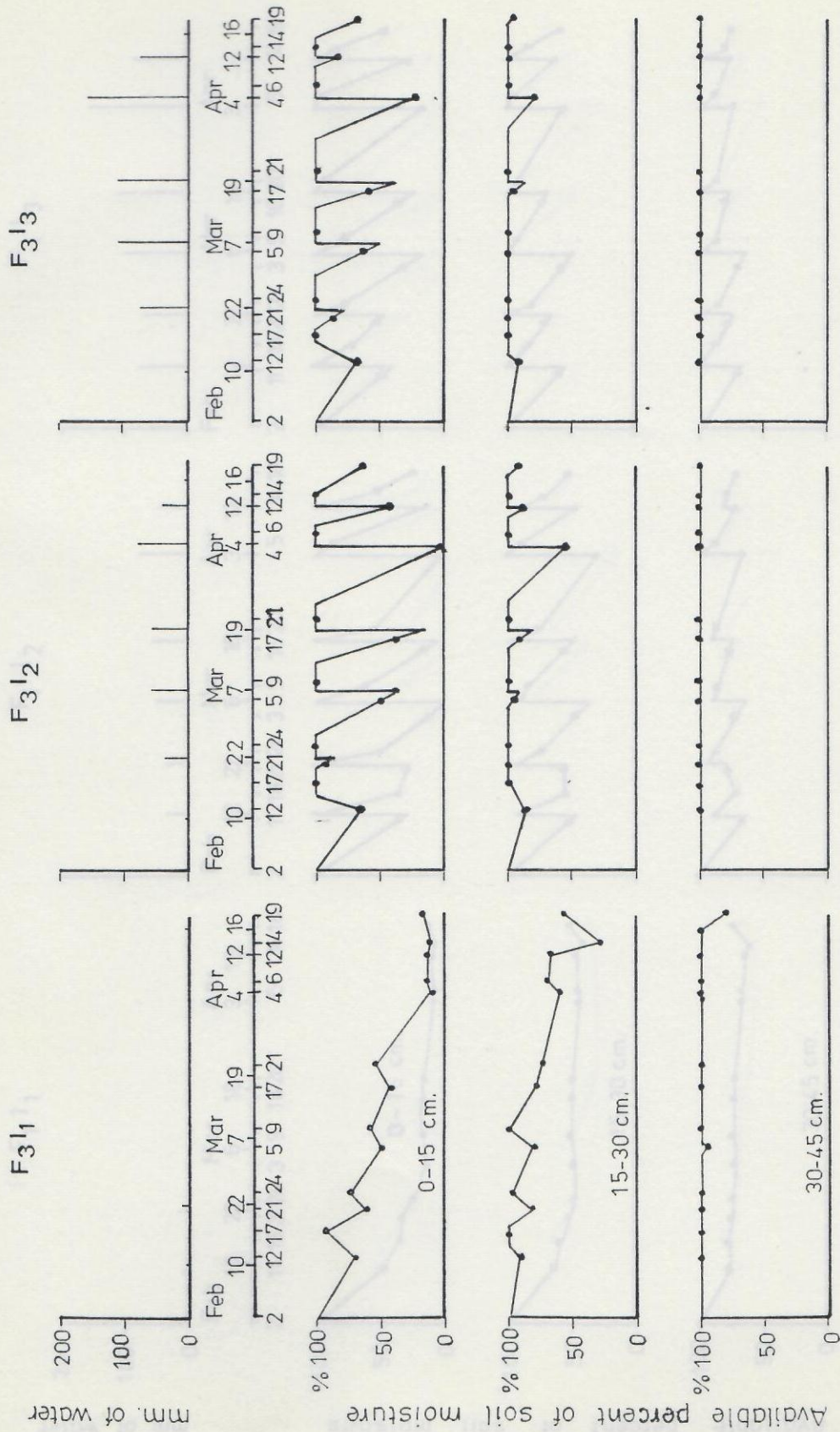

Fig. A3(3) Diagram Showing the Available Percent of Soil Moisture with the Input of Irrigation Water (cont.)

WTD2

F₁J₃

F₁J₂

F₂J₁I₁

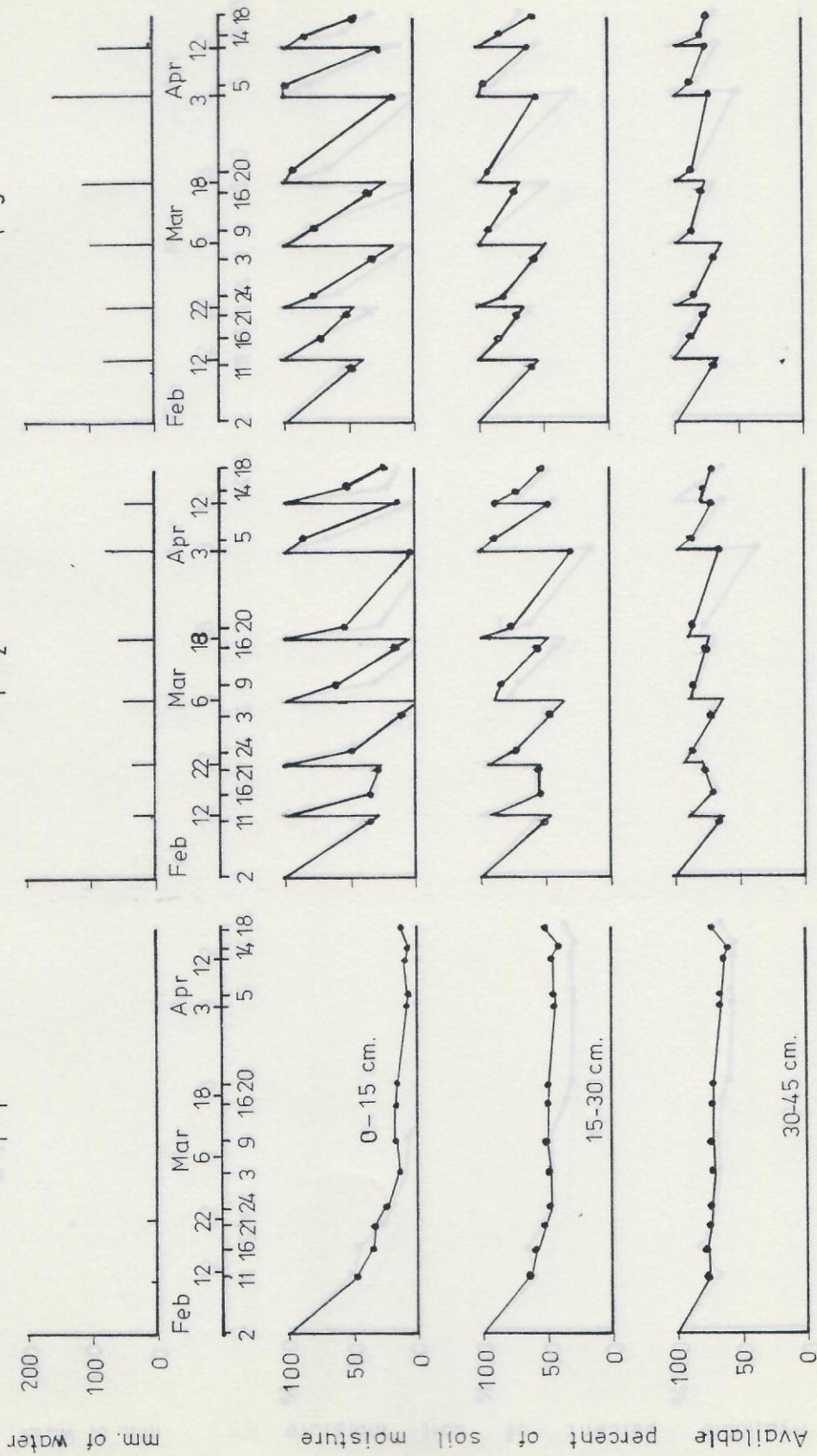

Fig. A3(4) Diagram Showing the Available Percent of Soil Moisture with the Input of Irrigation Water (cont.)

WTD2

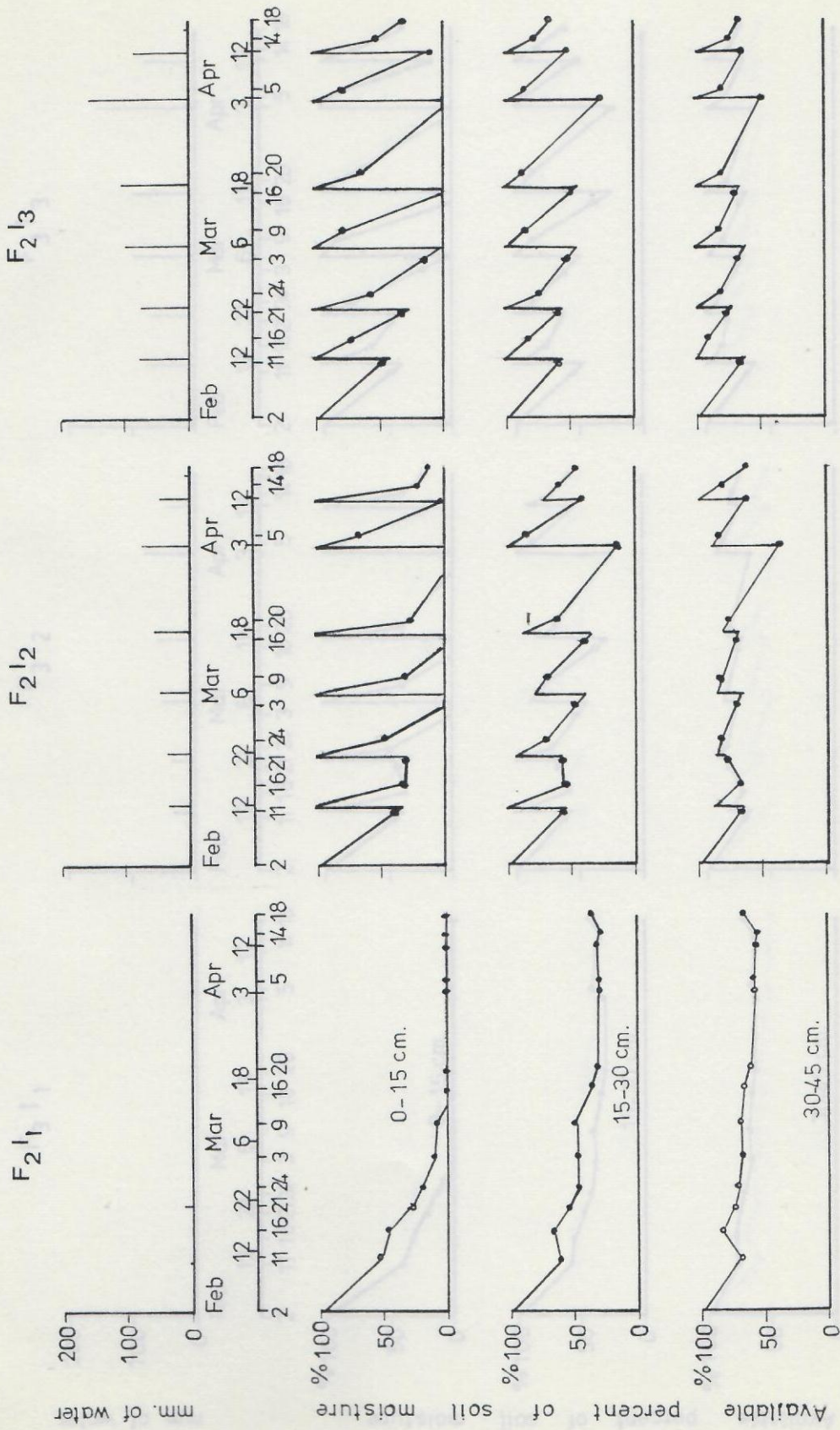

Fig. A3(5) Diagram Showing the Available Percent of Soil Moisture with the Input of Irrigation Water. (cont)

WTD2

F₃I₁

F₃I₂

F₃I₃

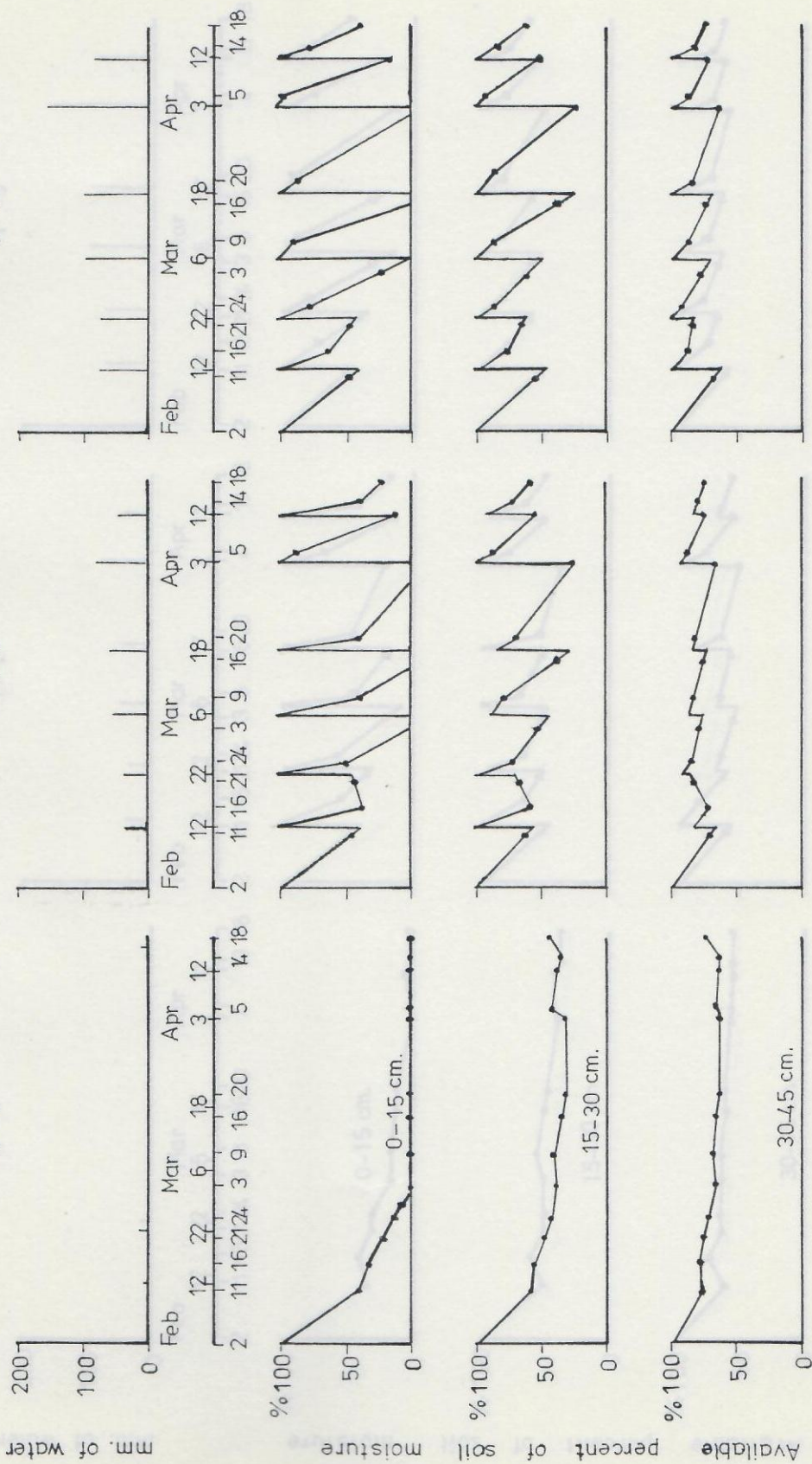

Fig. A3(6) Diagram Showing the Available Percent of Soil Moisture with the Input of Irrigation Water (cont.)

WTD 3

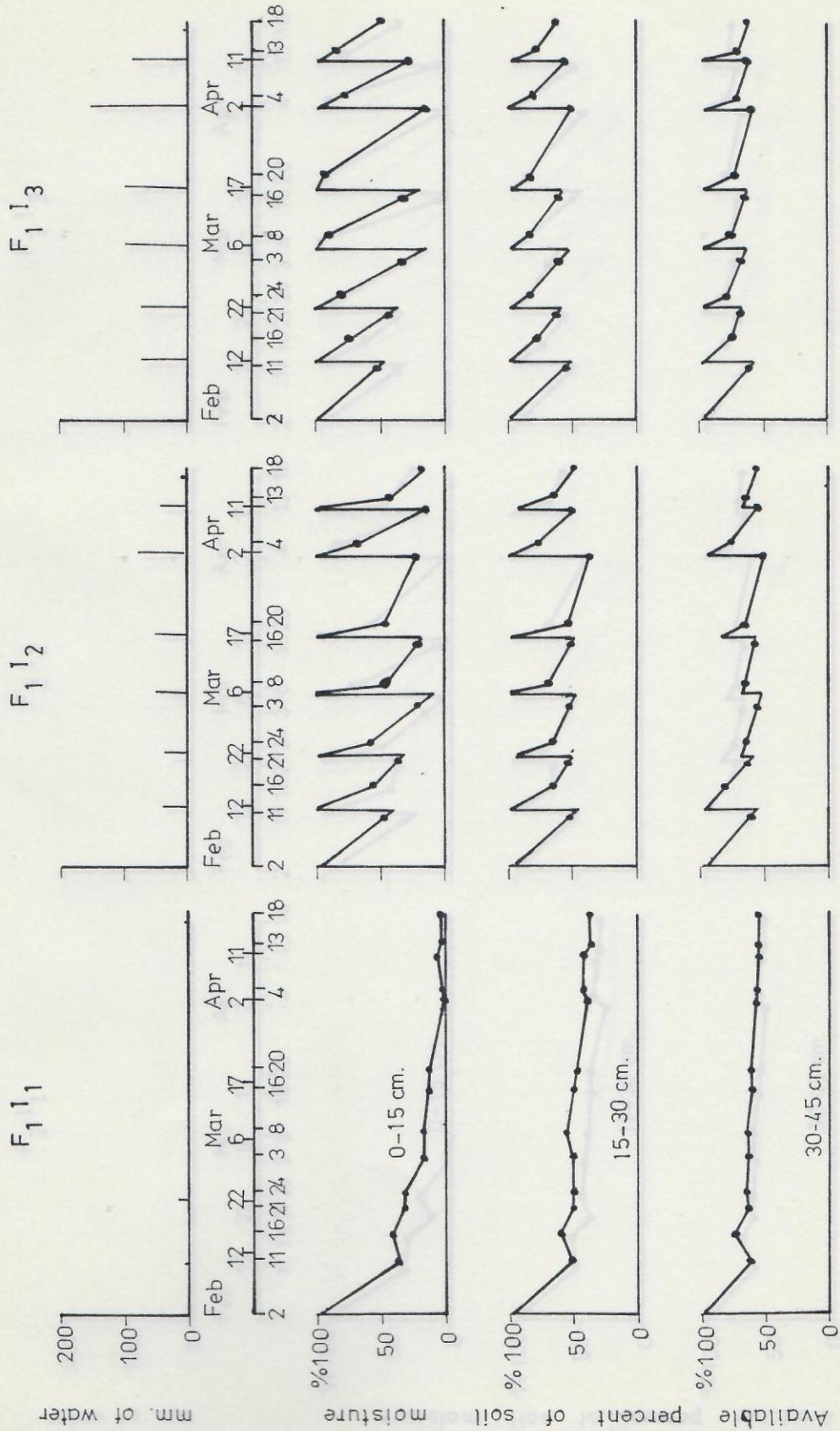

Fig. A3(7) Diagram Showing the Available Percent of Soil Moisture with the Input of Irrigation Water (cont.)

WTD3

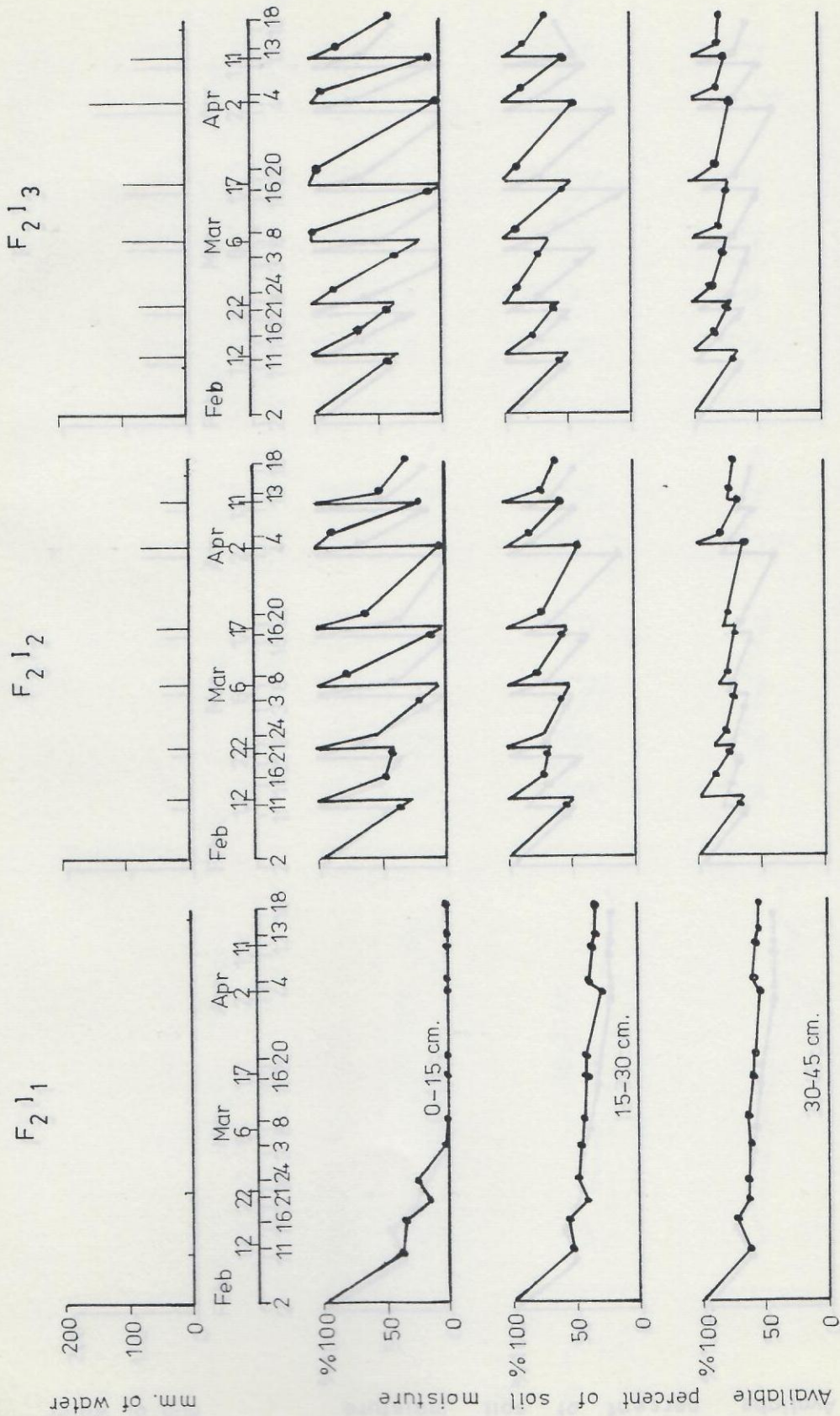

Fig. A3(8) Diagram Showing the Available Percent of Soil Moisture with the Input of Irrigation Water (cont.)

WTD 3

F₃J₃

F₃J₂

F₃J₁

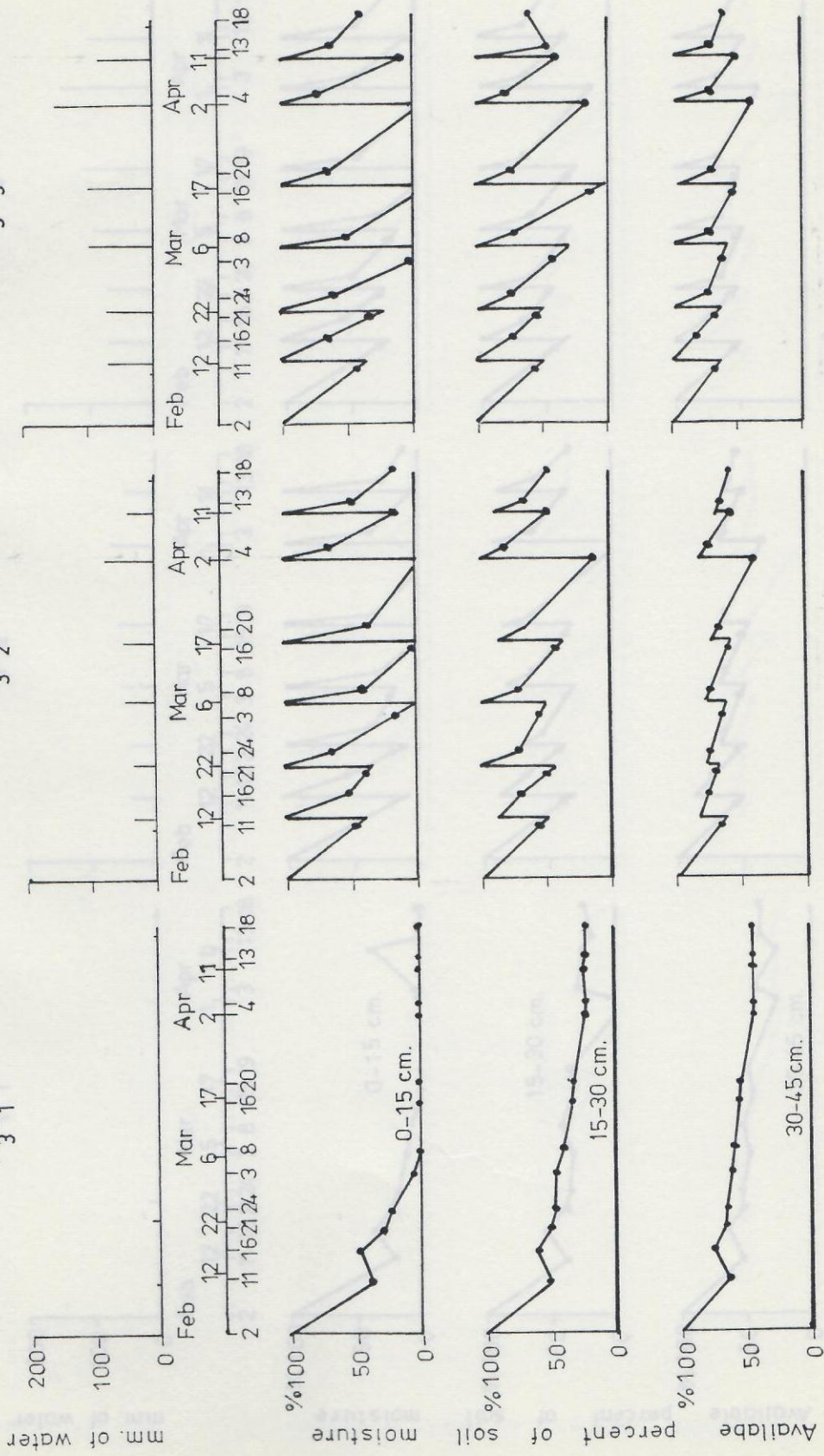

Fig. A3(9) Diagram Showing the Available Percent of Soil Moisture with the Input of Irrigation Water (cont.)

WTD4

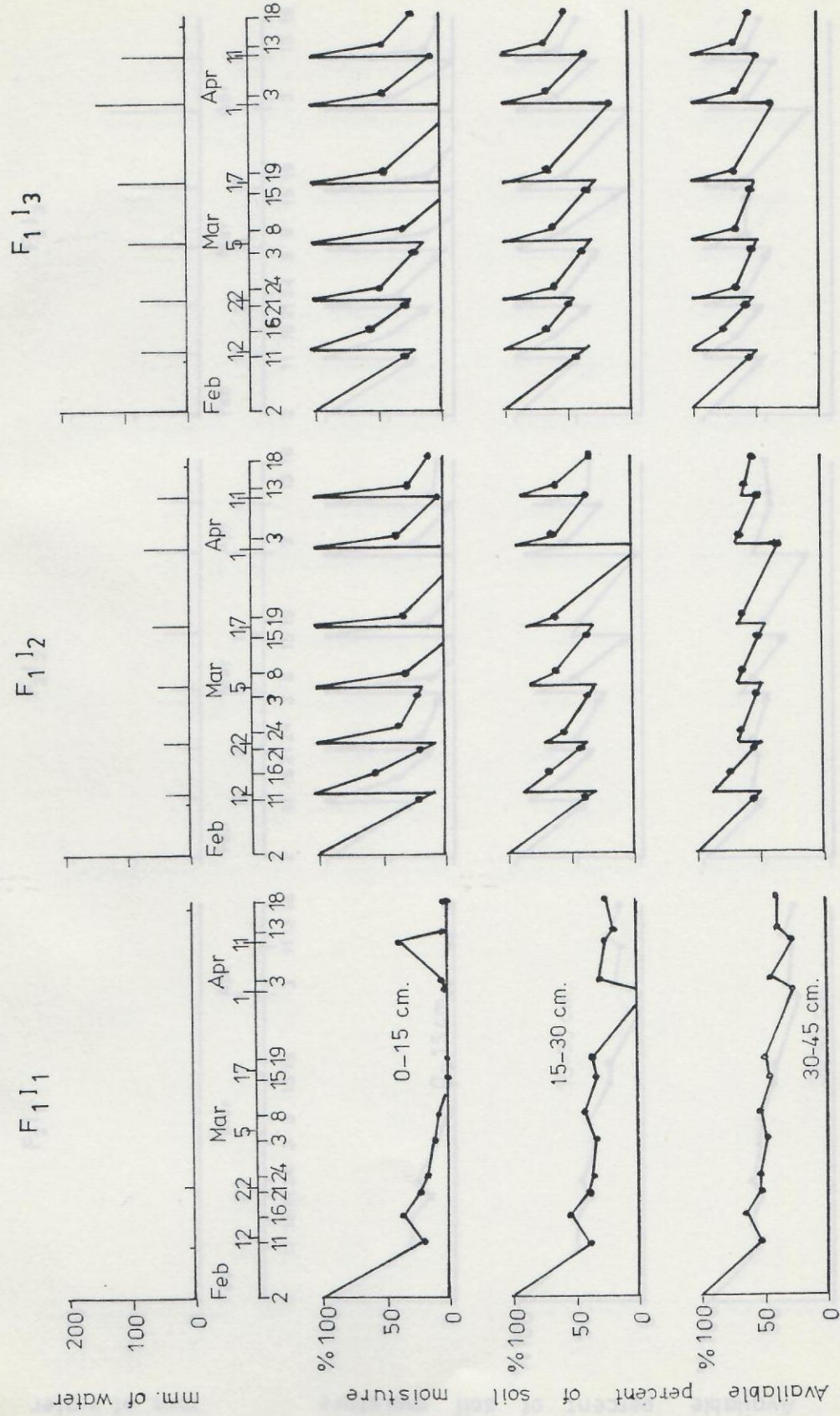

Fig. A3(10) Diagram Showing the Available Percent of Soil Moisture with the Input of Irrigation Water (cont.)

WTD 4

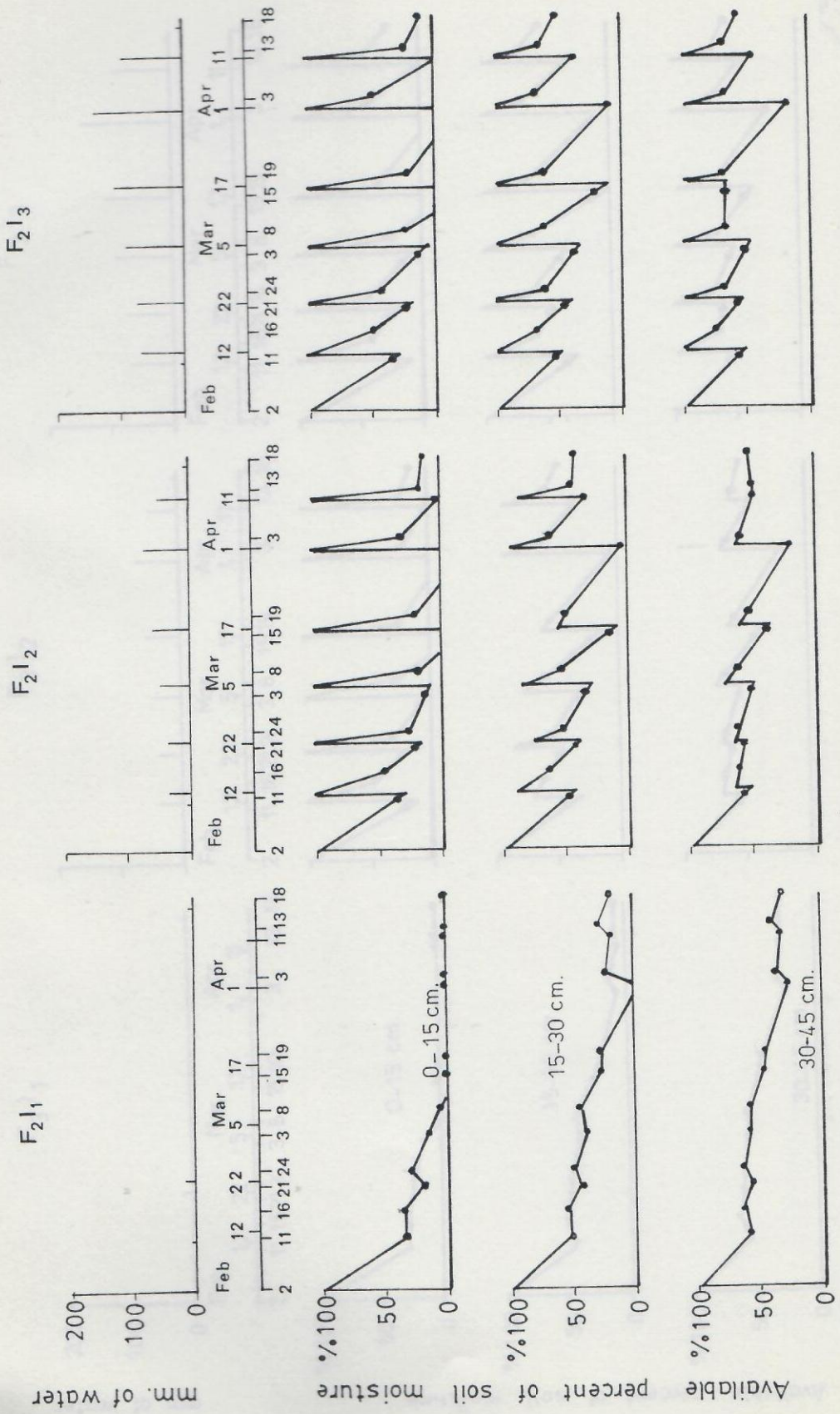

Fig. A3(11) Diagram Showing the Available Percent of Soil Moisture with the Input of Irrigation Water (cont.)

WTD4

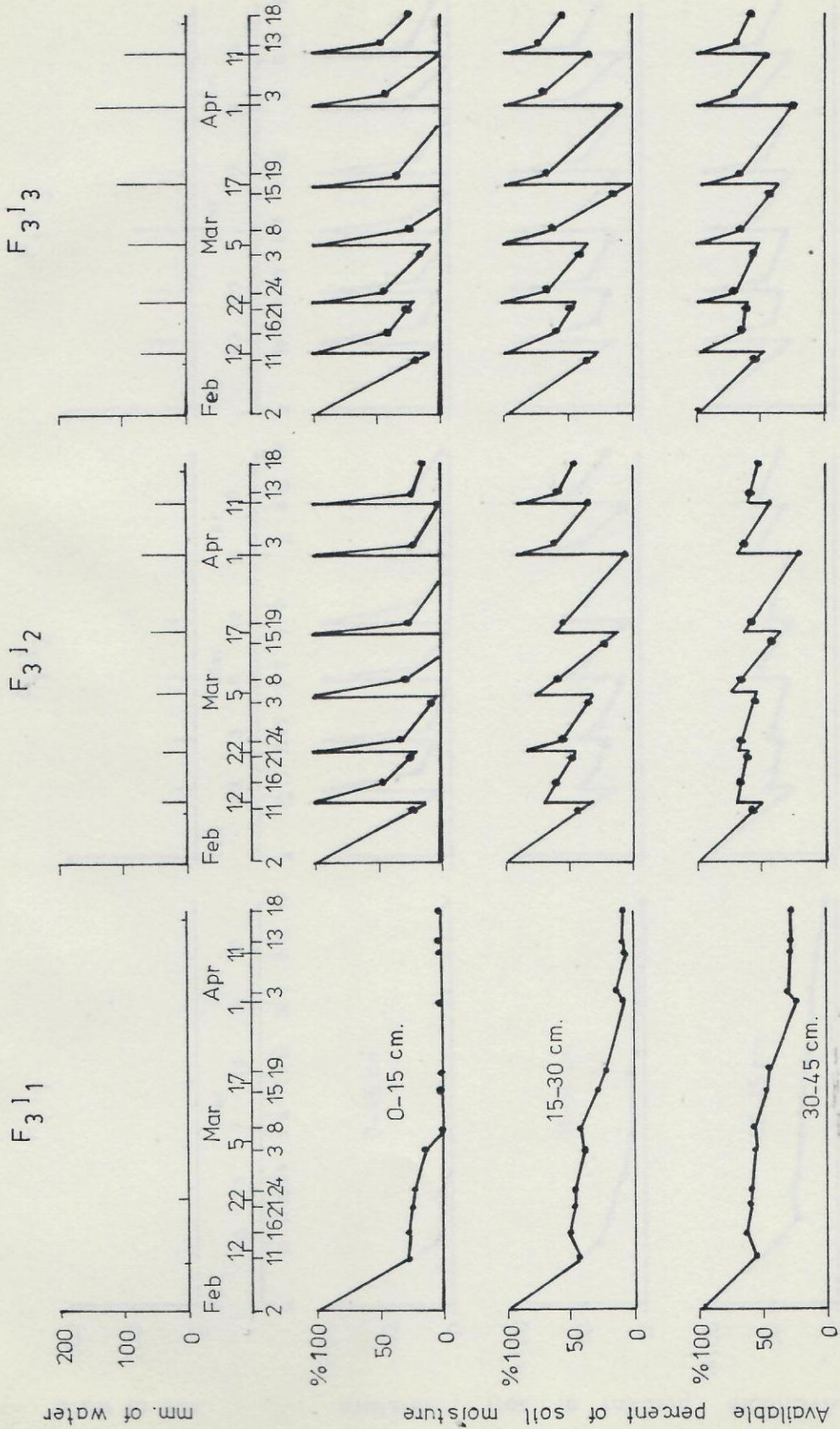

Diagram Showing the Available Percent of Soil Moisture with the Input of Irrigation Water (cont.)

Fig. A3(12)

WTD 5

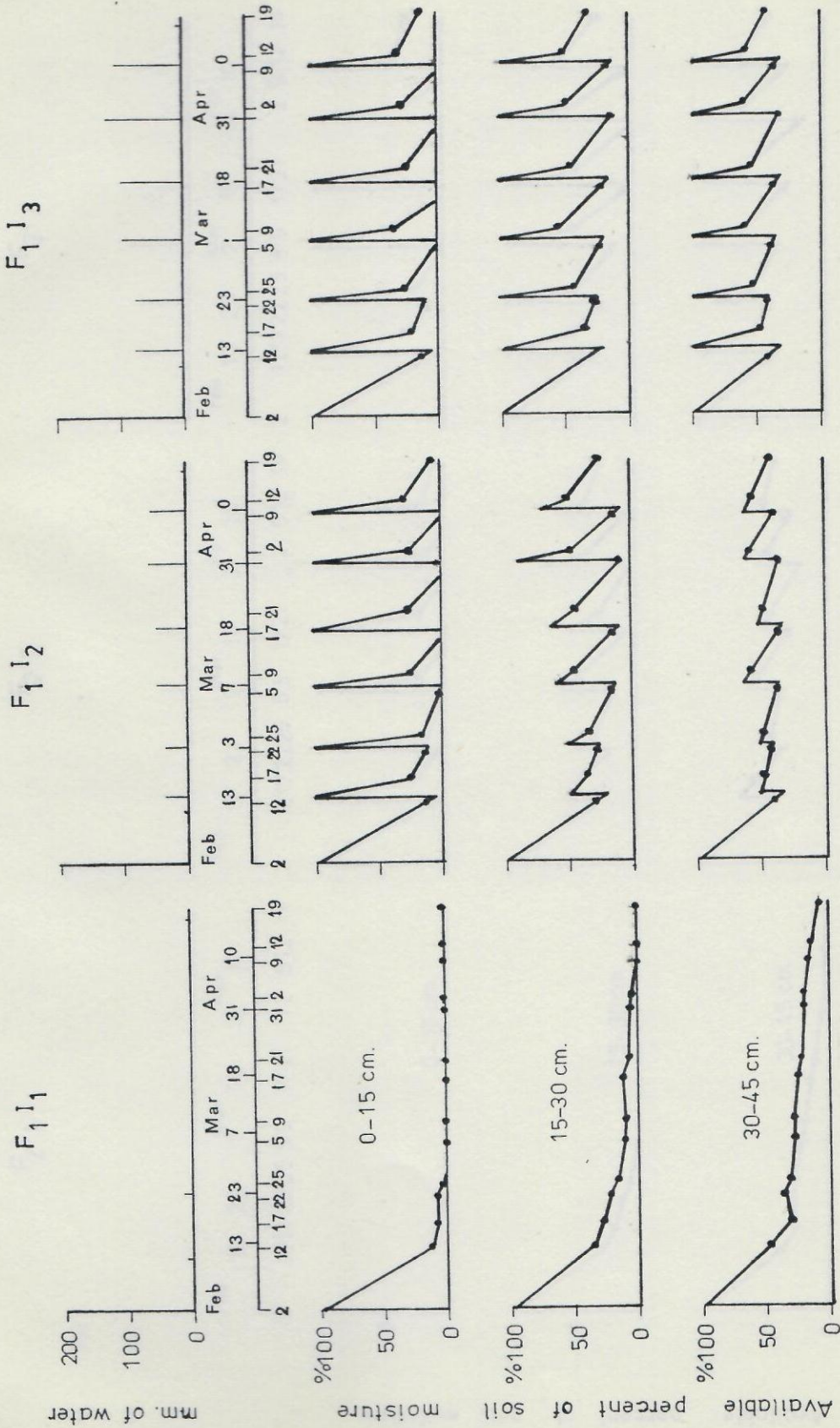

Fig. A3(13) Diagram Showing the Available Percent of Soil Moisture with the Input of Irrigation Water (cont.)

Appendix

WTD 5

F₂I₃

F₂I₂

F₂I₁

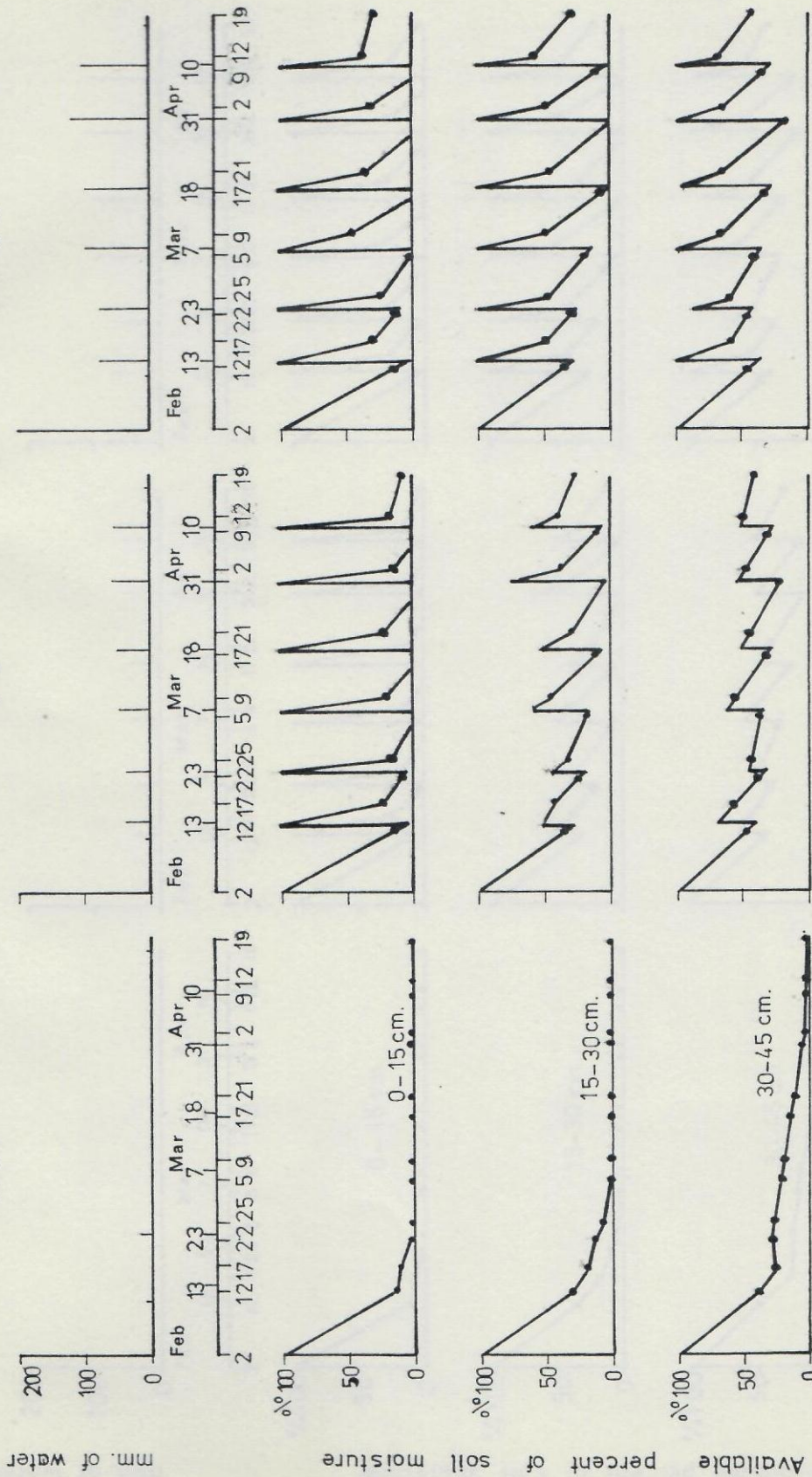

Fig. A3(14) Diagram Showing the Available Percent of Soil Moisture with the Input of Irrigation Water (cont.)

WTD 5

F₃I₃

F₃I₂

F₃I₁

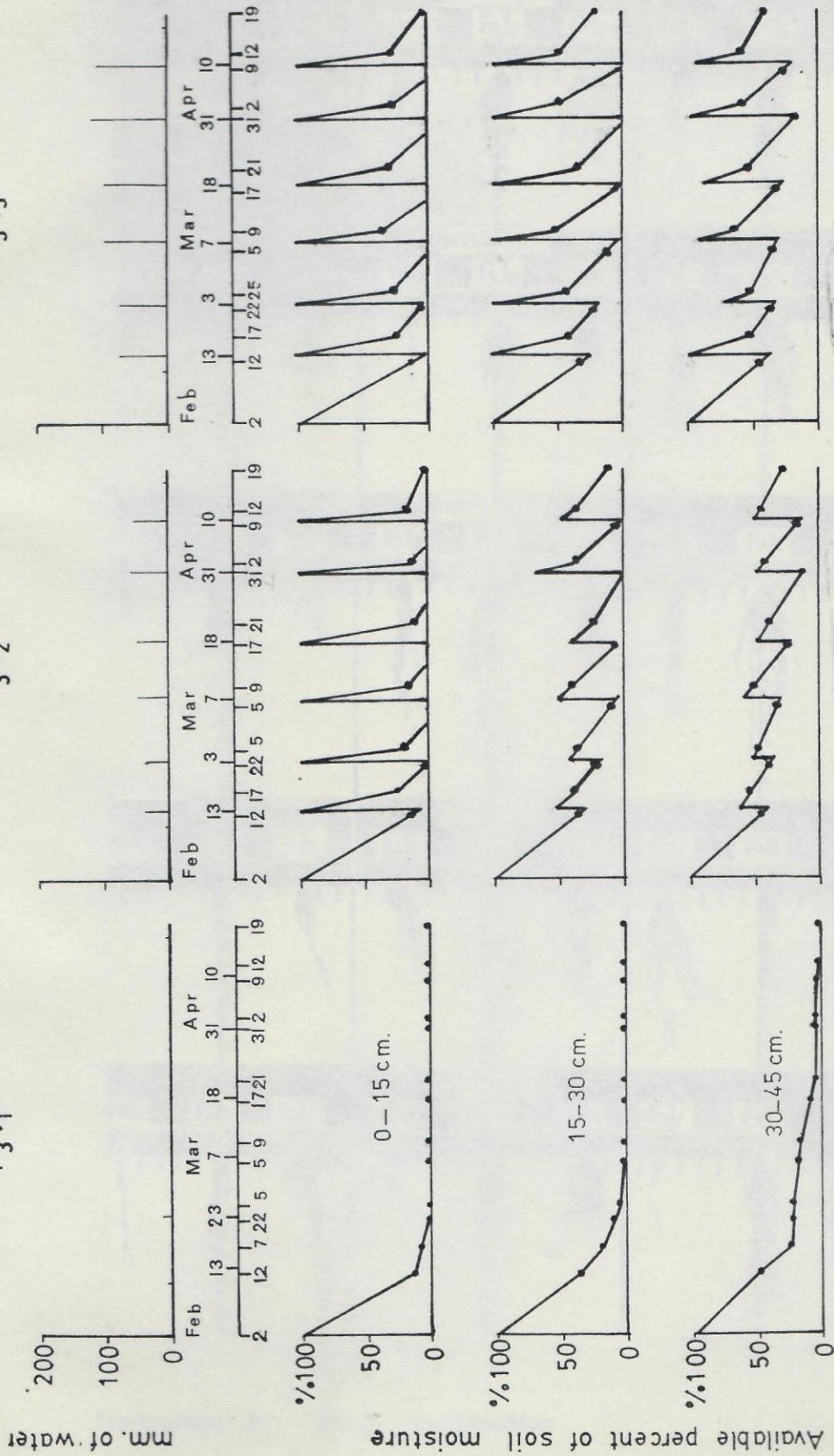
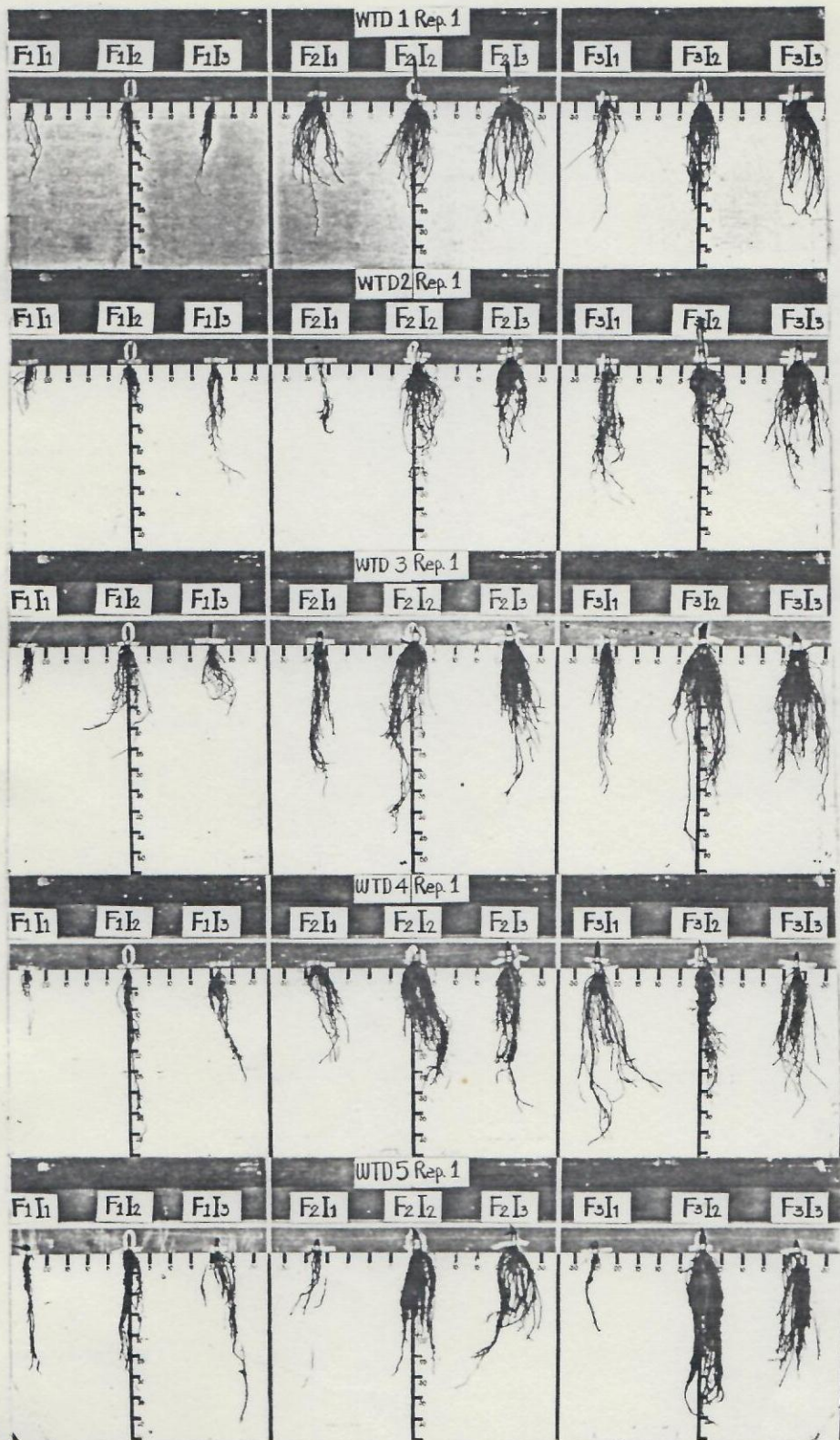

Fig. A3(15) Diagram Showing the Available Percent of Soil Moisture with the Input of Irrigation Water (cont.)



Photograph A1 Root Distribution