

Training Course : IRRIGATION DESIGN AND MANAGEMENT
(Irrigation Principles)

SOIL-WATER-PLANT RELATIONSHIPS

By

Dr. Varawoot Vudhivanich

Assistant Professor

Dept. of Irrigation Engineering
Kasetsart University

Faculty of Engineering
Kamphaengsaen Campus

Nakorn Pathom 73140

Contents

| | |
|--|----|
| 1. Physical Properties of Soils. | 1 |
| 1.1 Soil Texture. | 2 |
| 1.2 Soil Structure. | 2 |
| 2. Soil Water. | 5 |
| 2.1 Kinds of Water in the Soil. | 5 |
| 2.2 Available Moisture. | 6 |
| 2.3 Calculation of Soil Moisture. | 8 |
| 3. Plants. | 11 |
| 3.1 Root Systems. | 11 |
| 3.2 Moisture-Extraction Patterns. | 14 |
| 4. Infiltration. | 17 |
| 4.1 Introduction. | 17 |
| 4.2 Factors affecting infiltration rate. | 18 |
| 4.3 Infiltration Equation | 19 |
| 4.4 Determination of Infiltration. | 20 |
| 5. References. | 29 |

Soil-Water-Plant Relationships

Knowledge of soil-water-plant relationships is the most essential factor for successful management of irrigation water at farm level. An irrigation engineer can use this knowledge to determine when to irrigate, how much water to apply, irrigation frequency, application rate and etc. Therefore the soil-water-plant relationships need to be understood by irrigation engineers who desire to obtain the best use of irrigation water for their farms.

This chapter will discuss in detail the physical properties of soils, the soil water, the available moisture, the plant root zone and intake characteristics of soil which are important aspects of soil-water-plant relationships.

Soils

Soil is a storehouse of plant nutrients, a habitat for bacteria, an anchorage for plants, and a reservoir that stores water for use by the plant. The amount of water a soil can hold available for plant use is determined by its physical properties. This amount determines the length of time a plant can survive without irrigation or rain. It determines both the frequency of irrigation and the capacity of the irrigation system needed to insure continuous crop growth.

1. Physical Properties of Soils

Two important physical properties of soils are texture and structure. Soil texture refers to the proportion of various sizes of soil particles in a given soil. Soil structure refers to the manner in which the soil particles are arranged in groups or aggregates. Together soil texture and soil structure help to determine the supply of water and air in a soil.

1.1 Soil Texture

The sizes of particles making up a soil determine its texture. Most agricultural soils are composed of 3 kinds of soil particles namely; sand, silt and clay. The United States Department of Agriculture (USDA) has established a criteria for identification of soil particles according to the particle diameter as follows:

| Particles | Particle Diameter, mm. |
|-----------|------------------------|
| Sand | 0.05 - 2.0 |
| Silt | 0.002 - 0.05 |
| Clay | Smaller than 0.002 |

To determine the textural class of a given soil, the particle size distribution need to be identified. This can be done by hydrometer method. The USDA soil textural classification triangle as shown in Figure 1 can be used to identify the textural class of the soil based on the percentages of sand, silt and clay particles.

Example 1 A given soil has 50 % sand, 30 % of silt and 20 % of clay. What is the textural class of the soil?

Answer According to Figure 1, the soil is classified as Loam.

Given the soil texture, the water holding capacity, the infiltration rate and other soil properties can be found from Table 2.

1.2 Soil Structure

Soil structure is a soil properties relating to the arrangement of the soil particles. Structure influences the rate at which water and air enter and move through the soil. It also effects root penetration and the soil's nutrient supply.

Unlike texture, structure of the soil surface can be changed according to the way of cultivation and irrigation practices. Some of the recommended practices to maintain and improve the structure of irrigated soil are as follows:

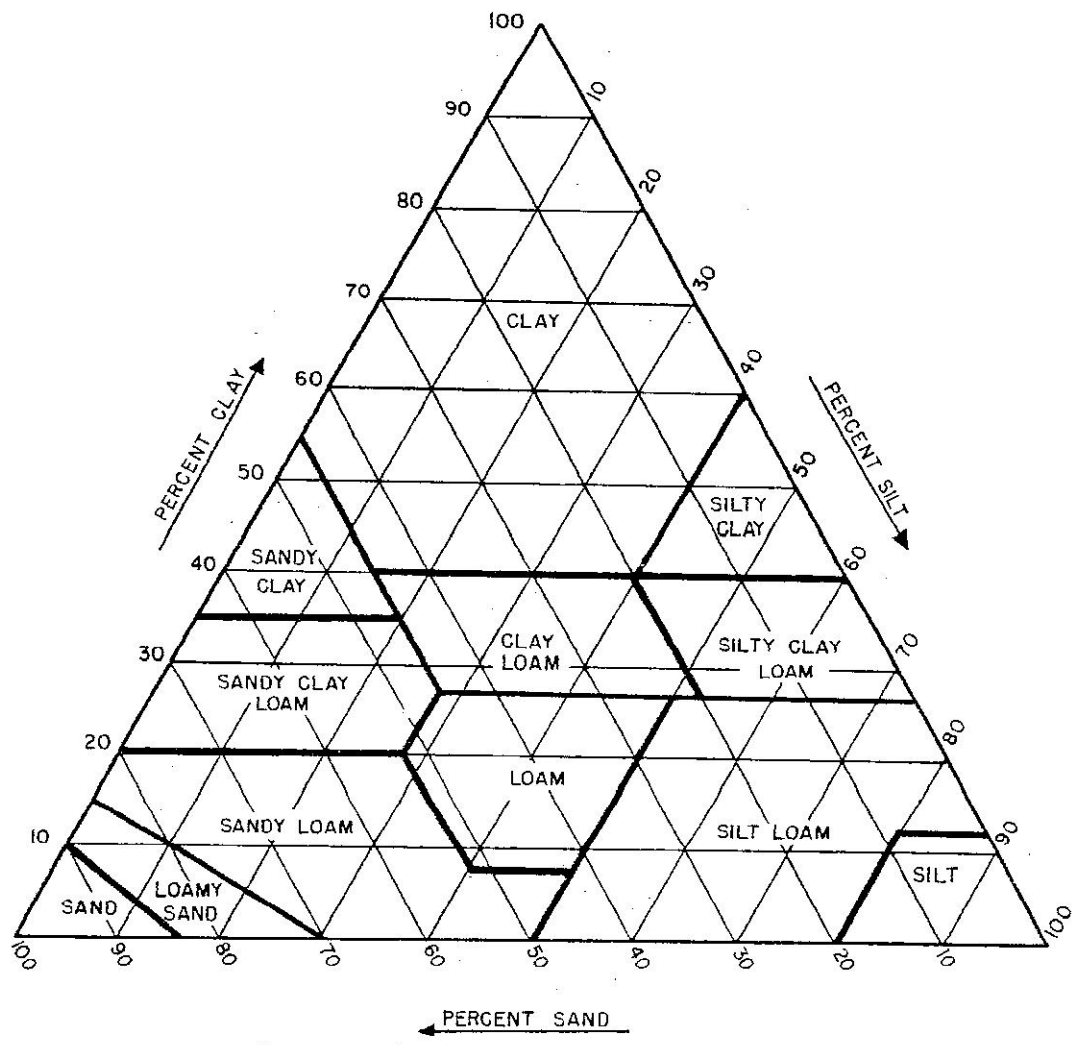

Figure 1 USDA Soil Textural Classification Triangle

Table 1 Representative Physical Properties of Soils (Israelsen and Hansen, 1967)

| Soil Tex- ture | Infiltration ¹ and Permeability Inches/hour I_f | Total Pore Space % N | Apparent Specific Gravity A_s | Field Capacity % FC | Permanent Wilting % PW | Total Available Moisture ² | | | |
|----------------------|--|------------------------------------|--|--------------------------------|-----------------------------------|---------------------------------------|--------------------------------|---|--|
| | | | | | | Dry Weight % $P_w = FC - PW$ | Volume % $P_v = P_w A_s$ | Inches per Foot $d = \frac{P_w A_s D}{100}$ | |
| Sandy | 2 (1-10) | 38 (32-42) | 1.65 (1.55-1.80) | 9 (6-12) | 4 (2-6) | 5 (4-6) | 8 (6-10) | 1.0 (0.8-1.2) | |
| Sandy Loam | 1 (0.5-3) | 43 (40-47) | 1.50 (1.40-1.60) | 14 (10-18) | 6 (4-8) | 8 (6-10) | 12 (9-15) | 1.4 (1.1-1.8) | |
| Loam | 0.5 (0.3-0.8) | 47 (43-49) | 1.40 (1.35-1.50) | 22 (18-26) | 10 (8-12) | 12 (10-14) | 17 (14-20) | 2.0 (1.7-2.3) | |
| Clay Loam | 0.3 (0.1-0.6) | 49 (47-51) | 1.35 (1.30-1.40) | 27 (23-31) | 13 (11-15) | 14 (12-16) | 19 (16-22) | 2.3 (2.0-2.6) | |
| Silty Clay | 0.1 (0.01-0.2) | 51 (49-53) | 1.30 (1.25-1.35) | 31 (27-35) | 15 (13-17) | 16 (14-18) | 21 (18-23) | 2.5 (2.2-2.8) | |
| Clay | 0.2 (0.05-0.4) | 53 (51-55) | 1.25 (1.20-1.30) | 35 (31-39) | 17 (15-19) | 18 (16-20) | 23 (20-25) | 2.7 (2.4-3.0) | |

Note: Normal ranges are shown in parentheses.

¹ Intake rates vary greatly with soil structure and structural stability, even beyond the normal ranges shown above.

² Readily available moisture is approximately 75% of the total available moisture.

- (1) plow below compacted layers, not at the same depth each year;
- (2) allow soil to air as long as practical after plowing before giving pre-planting irrigation or before preparing seed bed;
- (3) return all possible organic matter to the soil;
- (4) follow a good crop rotation of legumes, cash crops and fibrous-rooted crops; and
- (5) reduce cultivation and tillage operations to a minimum.

2. Soil Water

Since a constant supply of water in the soil is necessary for plant growth, the irrigation engineer is concerned with how water moves in a given soil, how much water a soil can hold and how much of it is available to plants, and how the water supply can be refilled. The first two are related to size and distribution of the soil pores and to size of the soil particles and their attraction for moisture. The amount of water a soil holds also depends on the amount of organic matter in the soil. Generally, the finer the soil particles and the larger the amount of organic matter, the more water a soil holds.

2.1 Kinds of Water in the Soil

The soil pores, spaces between the particles, form a network of connected cavities of various shape and size. When water is added to a dry soil by either rain or irrigation, it is distributed around the soil particles where it is held by adhesive and cohesive forces; it displaces air in the pore spaces and eventually fills the pores. When all the pores, large and small, are filled, the soil is said to be saturated and is at its maximum retention capacity.

The water in the large pores that moves downward freely under the influence of gravity is called gravitational water or free water. When the supply of water to the soil is cut off, water continues to drain from the large pores for a few days. In well-drained soils, the free water in the soil usually has been moved out before crops are damaged. The large pores are again filled with air. The moisture content of soil at this level is called field capacity.

Water in the small pores that still moves because of capillary forces is called capillary water. It moves more slowly than free water and can move in any direction but always in the direction of the greatest tension.

Evaporation from the surface and absorption of moisture by growing plants further reduce the amount of water in the soil until water no longer moves because of capillary forces. It is held so tightly as very thin films around the soil particles that it cannot be used by plants. If water is not added to the soil, the plants will die. The remaining water is called hygroscopic water and the moisture content in at this level is called ultimate wilting point.

There is a soil moisture level above the ultimate wilting point called permanent wilting point. At this level of moisture content, plants can no longer obtain enough moisture to meet transpiration requirements. The plants wilt and remain wilted unless water is added to the soil. When a plant wilts, growth stops. Therefore irrigation water should always be applied to a soil before the moisture content of the root zone is reduced to the permanent wilting point.

Figure 2 will explain the relationship between soil water and its availability to plants.

2.2 Available Moisture

In designing an irrigation system and in making recommendations for improved techniques of applying water, the irrigation engineer needs to know how much of the water in a soil is available to plants. The total amount of water a soil can hold between field capacity and the permanent wilting point is called available moisture. In practice, the soil moisture content should not be allowed to reduce near permanent wilting point because the growth will stop and the yield will be reduced. It is suggested that irrigation water be applied when a certain percentage of available moisture is depleted from field capacity. The soil moisture content where the irrigation should begin is called the critical moisture level or critical point.

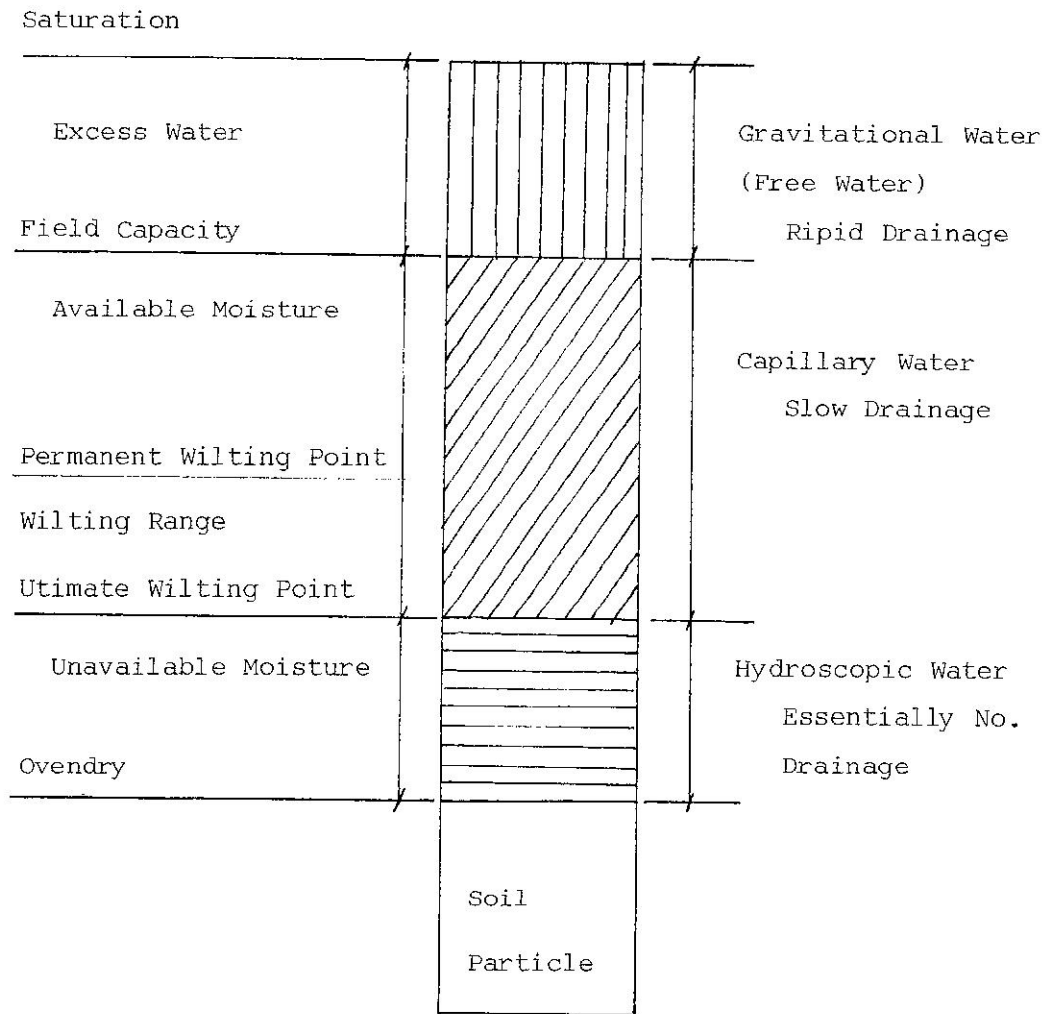

Figure 2 Kinds of Soil Water and Its Availability to Plants.

The difference between field capacity and the critical point is called allowable depletion. For general crops, the allowable depletion is 40 to 50% of available moisture. But the allowable depletion may be reduced to 30 to 35% for expensive crops.

2.3 Calculation of Soil Moisture

The direct measurement of soil moisture can be done by taking 100 gram or more of soil samples with a soil auger. The samples are then put in the cans with covers and taken to laboratory for weighing and drying. After weighing, the soil samples are kept in an oven at the temperature of 105°C for 24 hours or until they are free of moisture. The weight of moisture in the soil divided by the weight of oven-dry soil gives the moisture on dry weight basis.

There are three ways to express soil moisture.

(1) % of moisture on dry weight basis

$$P_w = \frac{W_w}{W_s} \times 100 \quad \dots\dots\dots (1)$$

where

P_w is the percentage of moisture on dry weight basis,

W_w is the weight of moisture in soil,

W_s is the weight of oven-dry soil.

(2) % of moisture on volumetric basis

$$P_v = \frac{V_w}{V} \times 100 \quad \dots\dots\dots (2)$$

where

P_v is the percent of moisture on volumetric basis

V_w is the volume of moisture in soil.

V is the soil bulk volume.

(3) Depth of water per depth of soil

$$\frac{d}{D} = \frac{P_v}{100} \quad \dots\dots\dots (3)$$

where

d is depth of water,

D is depth of soil.

Let A_s be an apparent specific gravity of soil and be defined as the ratio of weight of a given volume of dry soil to the weight of an equal volume of water or

$$A_s = \frac{W_s}{\gamma_w V} \dots\dots\dots (4)$$

where

γ_w is the water density .

If the water density is 1 gm per cubic centimeters, the numerical value of the apparent specific gravity is equal to the soil bulk density ($D_B = W_s/V$). However, the dimensions are not equal.

Given the apparent specific gravity (A_s), the % of moisture on dry weight basis can be converted to the % of moisture on volumetric basis according to the following relation;

$$P_v = P_w \cdot A_s \dots\dots\dots (5)$$

Combining Equation (3) and (5) gives

$$\frac{d}{D} = \frac{P_w \cdot A_s}{100}$$

$$\text{or } d = \frac{P_w \cdot A_s \cdot D}{100} \dots\dots\dots (6)$$

Usually, for conveniences the soil moisture is expressed as depth of water per depth of root zone. Multiply the d/D by the root zone depth, the soil moisture within the root zone is known. If the field capacity in term of depth is given, the depth of water to be applied can be calculated. Multiplying the depth of water by area, the total amount of irrigation water is known. This is the net irrigation amount. The gross amount can be determined if the irrigation efficiency is known.

$$\text{Irrigation Efficiency} = 100 \times \frac{\text{Net Amount}}{\text{Gross Amount}} \dots\dots\dots (7)$$

Example 2 In determination of soil moisture content on gravimetric method, the following data are recorded.

Weight of moist soil including can = 138 gm.

Weight of oven-dry soil including can = 105 gm.

Weight of can = 17 gm.

Determine the soil moisture content in % on dry weight basis (Pw).

Solution

Weight of oven-dry soil (Ws) = 105-17 = 88 gm.

Weight of moisture in soil (Ww) = 138-105 = 33 gm.

% moisture on dry weight basis (Pw) = $\frac{33}{88} \times 100 = 37.5$

If the soil is loam, determine depth of moisture per 1 meter of soil depth.

From Table 1, As = 1.40 (average value)

$$\begin{aligned} d &= \frac{Pw \cdot As \cdot D}{100} \\ &= \frac{37.5 \times 1.40 \times 1.00}{100} \\ &= 0.525 \quad \text{m.} \end{aligned}$$

Example 3 Determine the depth of irrigation water applied from the following data.

| Soil textures | Depth of layer cm. | As | Soil moisture before irri- gation, Pw ₁ | Soil moisture after irriga- tion, Pw ₂ |
|---------------|-----------------------|------|--|---|
| Loamy sand | 0-20 | 1.15 | 8.3 | 21.1 |
| Loamy sand | 20-35 | 1.25 | 8.7 | 22.5 |
| Loamy sand | 35-50 | 1.23 | 5.1 | 17.0 |
| Sand | 50-65 | 1.39 | 3.0 | 9.8 |
| Sand | 65-80 | 1.47 | 1.4 | 6.0 |

Solution

Since the soil in the root zone is not uniform, calculation will done layer by layer.

| Soil Texture | Depth of layer cm. | As | $Pw_2 - Pw_1$ | $d = \frac{(1)(2)(3)}{100}$ cm. |
|--------------|-----------------------|------|---------------|------------------------------------|
| | (1) | (2) | (3) | (4) |
| Loamy sand | 20 | 1.15 | 12.8 | 2.94 |
| Loamy sand | 15 | 1.25 | 13.8 | 2.59 |
| Loamy sand | 15 | 1.23 | 11.9 | 2.20 |
| Sand | 15 | 1.39 | 6.8 | 1.42 |
| Sand | 15 | 1.47 | 4.6 | 1.01 |
| Total | | | | 10.16 |

The depth of irrigation water applied = 10.16 cm.

3. Plants

To design a successful irrigation system, the irrigation engineer must know the rooting characteristics of plants and how plants use moisture. Since a continuous supply of available moisture is necessary for good plant growth, the irrigation system for any given crop must be designed to supply right amount of water during that crop's peak-use period. To determine the amount of soil moisture available to that crop, it is necessary to know from what depth of soil the plants get their moisture on their moisture-extraction pattern, and how fast they use moisture.

3.1 Root systems

The root system of plants is fixed by heredity and root environment. Each species has its own characteristic growth habit. Some plants have a tap root that penetrates deeply into soil under favorable conditions. Other plants are slow growing and develop shallow primary roots and many laterals.

The root penetration is usually limited by factors such as a compacted layer, a layer of dry soil, a high water table, a rock layer and etc. Figure 3 illustrates the effect of some of the limiting

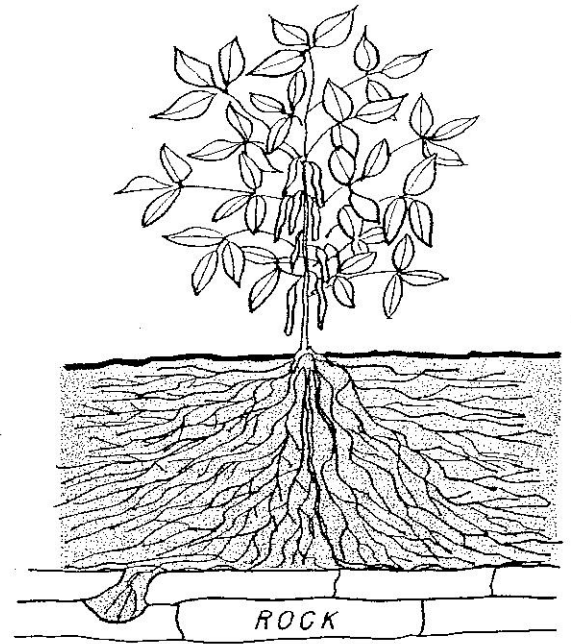
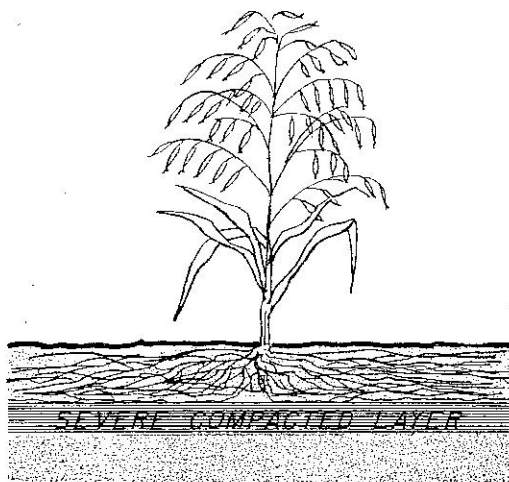
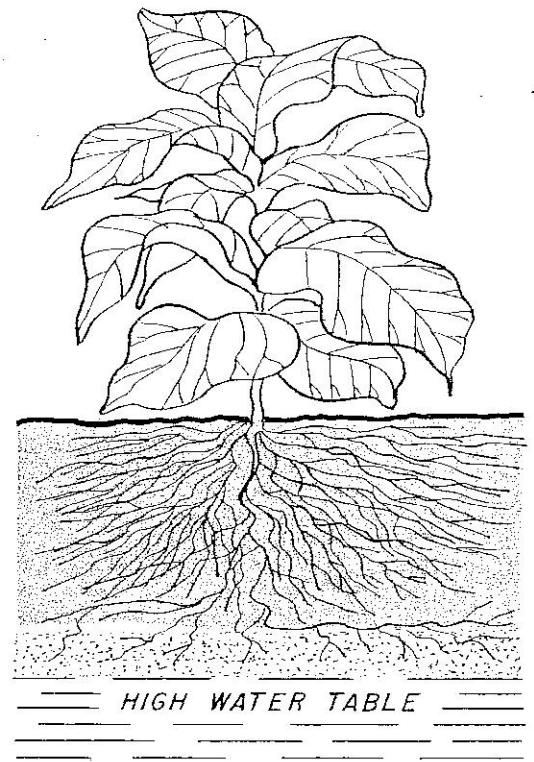
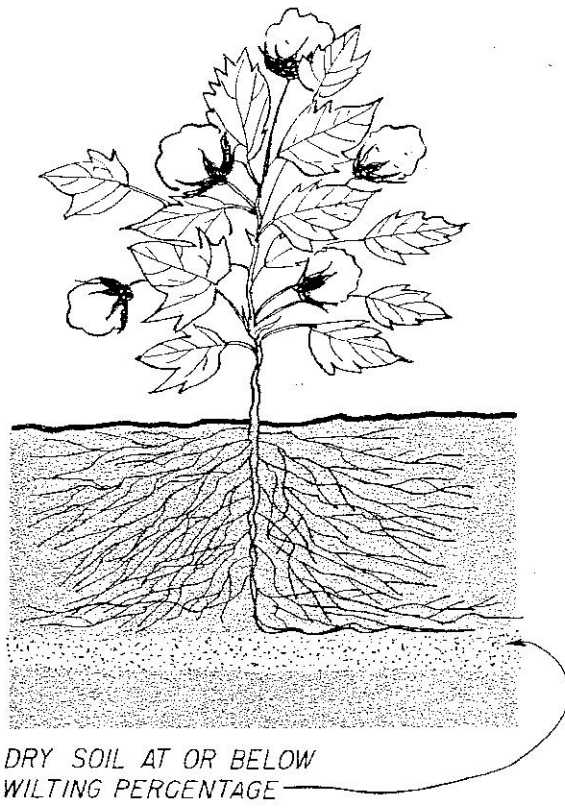

Figure 3 Soil effects on root development.

factors in soil on root development. Under normal conditions with adequate supply of moisture, the approximate rooting depth of crops are shown in Table 2.

3.2 Moisture-Extraction Patterns

For most plants, the concentration of root is greatest in the upper part of the root zone (usually in the top 30 centimeters) and near the base of the plant. Extraction of water is most rapid in the zone of greatest root concentration. As the amount of moisture in this part of the root zone is diminished, soil-moisture tension increases. Plants then get moisture from lower parts of the root zone. In uniform soil with an adequate supply of available moisture, almost all plants have similar moisture-extraction patterns. The usual extraction pattern (Figure 4) shows that plants extract 40 % of moisture from the upper quarter of the root zone, 30 % from the second quarter, 20 % from the third quarter and 10 % from the bottom quarter. Values for individual crops are within a range of $\pm 10\%$.

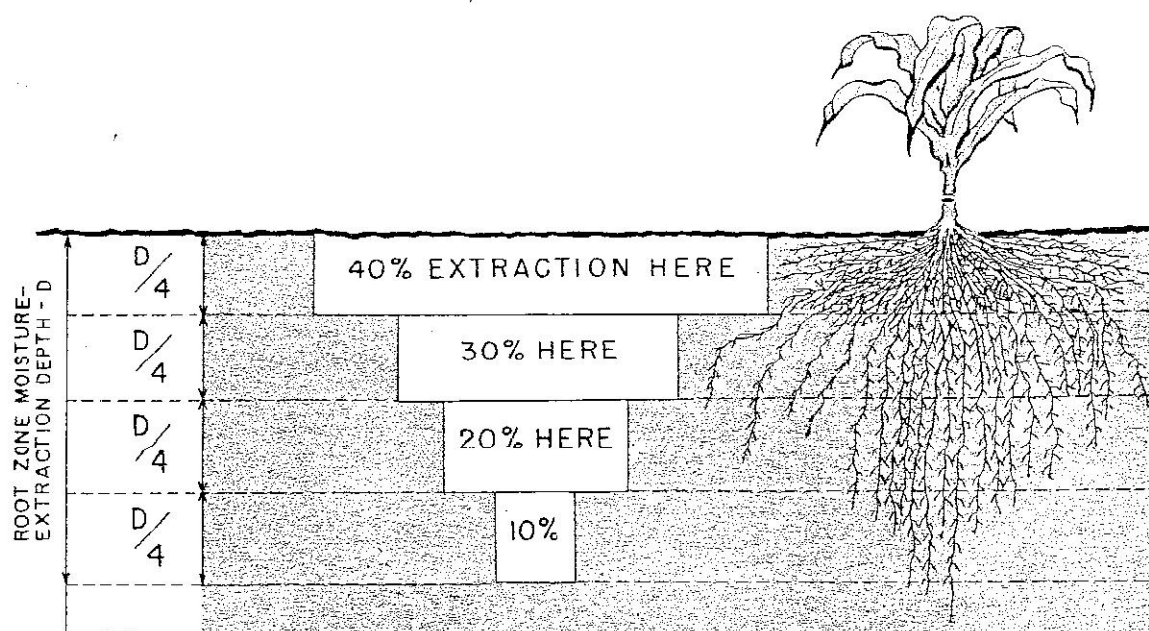

Figure 4 Average moisture-extraction pattern of plants growing in a soil without restrictive layers and with an adequate supply of available moisture throughout the root zone.

Table 2 Rooting depth of full grown crops in soil without restricting layer and with adequate moisture.

| Crop | Rooting Depth (m) | Crop | Rooting Depth (m) |
|---------------|-------------------|----------------|-------------------|
| Alfalfa | 1.0 - 2.0 | Melons | 1.0 - 1.5 |
| Banana | 0.5 - 0.9 | Olives | 1.2 - 1.7 |
| Barley | 1.0 - 1.5 | Onions | 0.3 - 0.5 |
| Beans | 0.5 - 0.7 | Palm trees | 0.7 - 1.1 |
| Beets | 0.6 - 1.0 | Peas | 0.6 - 1.0 |
| Cabbage | 0.4 - 0.5 | Peppers | 0.5 - 1.0 |
| Carrots | 0.5 - 1.0 | Pineapple | 0.3 - 0.6 |
| Celery | 0.3 - 0.5 | Potatoes | 0.4 - 0.6 |
| Citrus | 1.2 - 1.5 | Safflower | 1.0 - 2.0 |
| Clover | 0.6 - 0.9 | Sisal | 0.5 - 1.0 |
| Cotton | 1.0 - 1.7 | Sorghum | 1.0 - 2.0 |
| Cucumber | 0.7 - 1.2 | Soybeans | 0.6 - 1.3 |
| Dates | 1.5 - 2.5 | Spinach | 0.3 - 0.5 |
| Dec. orchards | 1.0 - 2.0 | Strawberries | 0.2 - 0.3 |
| Flax | 1.0 - 1.5 | Sugarbeet | 0.7 - 1.2 |
| Grains small | 0.9 - 1.5 | Sugarcane | 1.2 - 2.0 |
| winter | 1.5 - 2.0 | Sunflower | 0.8 - 1.5 |
| Grapes | 1.0 - 2.0 | Sweet potatoes | 1.0 - 1.5 |
| Grass | 0.5 - 1.5 | Tobacco early | 0.5 - 1.0 |
| Groundnuts | 0.5 - 1.0 | late | |
| Lettuce | 0.3 - 0.5 | Tomatoes | 0.7 - 1.5 |
| Maize | 1.0 - 1.7 | Vegetables | 0.3 - 0.6 |
| | | Wheat | 1.0 - 1.5 |

Example 4 Determine the depth of water to apply to bring the soil moisture back to field capacity. The given data are:

| | |
|---|-----------|
| Soil moisture content before irrigation (P_w) | = 8.3 |
| Field capacity (P_w) | = 21.1 |
| Root zone depth (D) | = 1.20 m. |
| Apparent specific gravity (A_s) | = 1.15 |

Solution

$$\begin{aligned}
 d &= \frac{P_w \cdot A_s \cdot D}{100} \\
 &= \frac{(21.1 - 8.3) \times 1.15 \times 1.20}{100} \\
 &= 0.1766 \text{ m.} \\
 &= 17.66 \text{ cm.}
 \end{aligned}$$

∴ The depth of irrigation water is 17.66 cm.

Example 5 The soil moisture measurements in the root zone of corn field of 160 hectares indicate that the average soil moisture is 14 % on dry weight basis. The analysis of soil show that the soil textural class is Loam with the apparent specific gravity of 1.45, field capacity and permanent wilting point of 20 and 10 % on dry weight basis respectively. The corn has 70 cm of root zone depth. The critical moisture level is 40 of the available moisture.

Is it proper time to irrigate the corn ?

How much water must be pumped from the canal to satisfy the water requirement of the 160 ha. of corn field, if the application efficiency is 70 % and the conveyance efficiency is 60 % ?

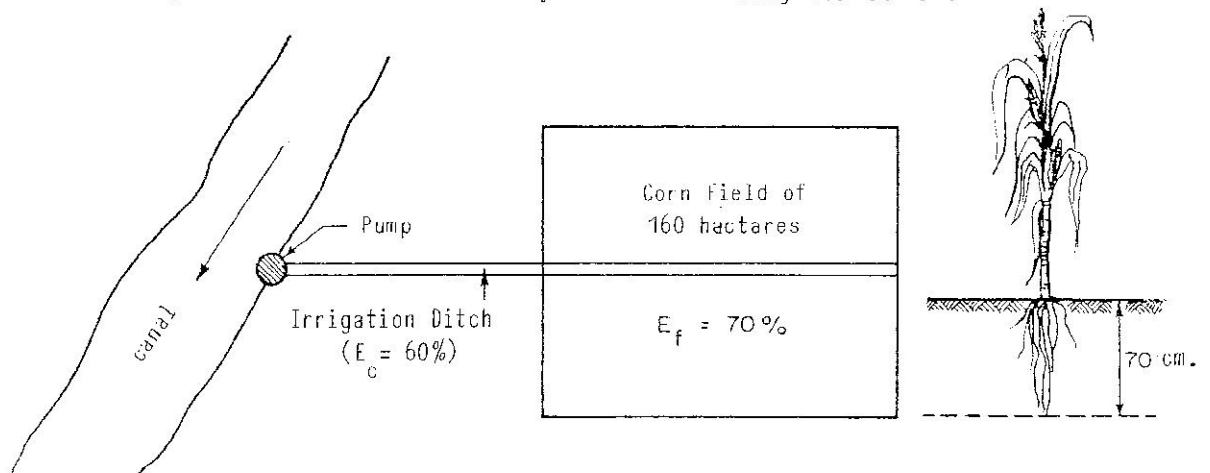

Solution

- (1) Determine the critical moisture level and compare to the actual soil moisture to decide when to irrigate.

$$\begin{aligned} \text{Available moisture (Pw)} &= 20 - 10 = 10 \\ \text{Critical point} &= 40\% \text{ of available moisture} \\ \text{Critical point (Pw)} &= 10 + 0.4 (10) = 14 \end{aligned}$$

Answer : The actual soil moisture indicates immediate irrigation is needed.

- (2) Determine the amount of water to be pump from the canal.

$$\begin{aligned} \text{The depleted soil moisture (Pw)} &= \text{field capacity} - \text{soil moisture in root zone} \\ &= 20 - 14 \\ &= 6 \\ \text{As} &= 1.45 \\ \text{D} &= 70 \quad \text{cm.} \end{aligned}$$

The net depth of water to be applied (d)

$$\begin{aligned} &= \frac{6 \times 1.45 \times 70}{100} \quad \text{cm.} \\ &= 6.09 \quad \text{cm.} \end{aligned}$$

The net volume of water to be applied

$$\begin{aligned} &= \frac{6.09}{100} \times 160 \times 10,000 \quad \text{m}^3 \\ &= 97,440 \quad \text{m}^3 \end{aligned}$$

The amount of water to be pumped from the canal

$$\begin{aligned} &= \frac{97,440}{0.6 \times 0.7} \quad \text{m}^3 \\ &= 231,905 \quad \text{m}^3 \end{aligned}$$

4. INFILTRATION

4.1 Introduction

Infiltration is defined as the movement of water from the surface into the soil. All water, either from rainfall or Irrigation water, which enters the soil enters via infiltration. Knowledge of the infiltration characteristics of a soil is basic information required for designing efficient irrigation systems. The soil infiltration rate will affect advance and recession times, deep percolation and tailwater runoff in furrow and border systems, advance and ponding times in level basins, and maximum allowable application rate for sprinkler or drip irrigation systems.

The time rate at which water is absorbed by the soil is the infiltration rate which has a unit of volume per unit area per unit time or equivalently depth per unit time. Cumulative infiltration or sometimes called cumulative depth is the total accumulated depth that enters the soil in a given time period. The cumulative infiltration is thus the integration of the infiltration rate, and conversely, the infiltration rate is the derivative of the cumulative infiltration.

Define that

I is the infiltration rate,

D is the cumulative infiltration,

and t is the elapsed time or an opportunity time

$$D = \int_0^t I dt \dots\dots\dots (8)$$

$$\text{and } I = \frac{dD}{dt} \dots\dots\dots (9)$$

The rate at which water infiltrate soils usually decreases over time until it becomes nearly constant. The nearly constant rate of infiltration that develops after some time has elapsed from the start of irrigation is known as basic infiltration rate, denoted by I_b . The decrease is caused by the decreasing capillary pressure of the soil as it becomes wet. The constant rate is due to the constant gravity force and the other components of the driving force. Figure 5

shows typical infiltration rate and cumulative infiltration curves for an agricultural soil.

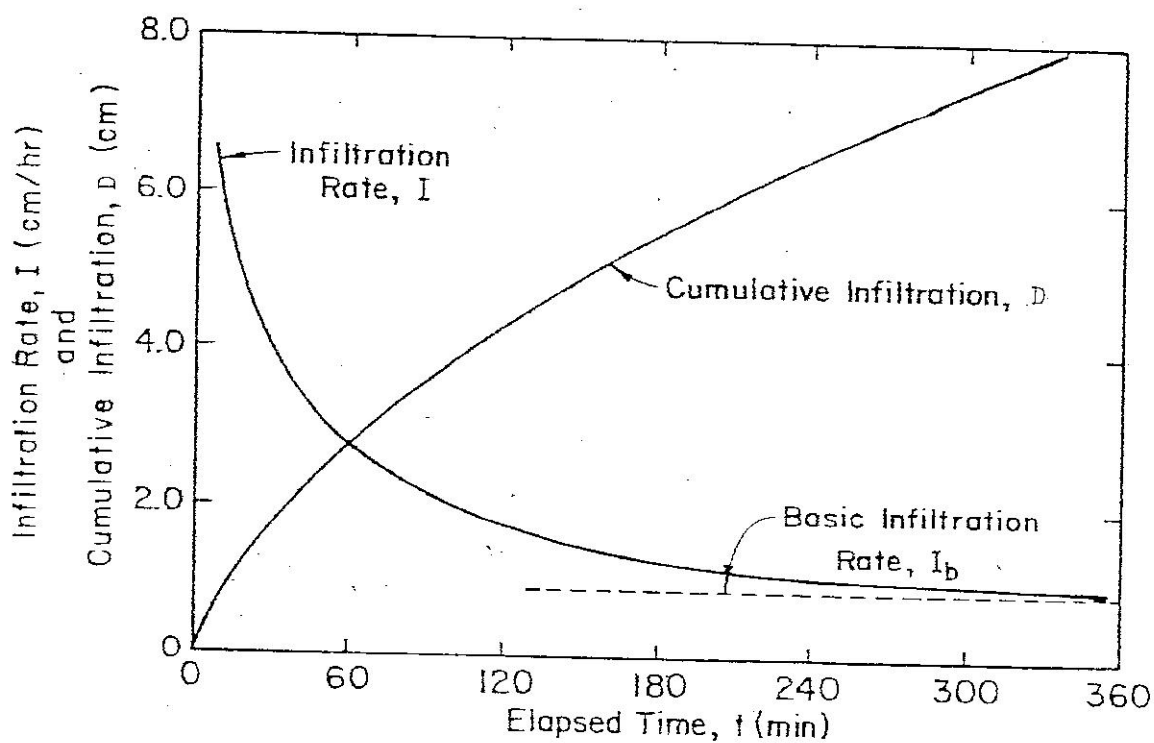

Figure 5. Typical infiltration rate and cumulative infiltration curves.

4.2 Factors affecting infiltration rate

Infiltration rate varies from place to place on a field and it also varies with time. Sandy soils may have rates in excess of 25 cm./hr. whereas clay soils may have rates approaching zero when soil structure has been practically destroyed by faulty management. The major factors affecting the infiltration of water into the soil are:

- (1) the soil moisture content,
- (2) soil texture,
- (3) soil structure,
- (4) conditions of the soil surface,
- (5) vegetative cover,
- (6) depth of water on the soil surface

Pre-existing soil moisture content will affect the initial infiltration rate. Drier soils will have higher initial rates, due to their high capillary pressure. As the soil moisture content rises, the rate decreases.

Infiltration rates are usually lower in soils of fine texture, clay soils, than in soils of coarse texture such as sandy soils due to pore spaces between soil particles.

Soil layers with low hydraulic conductivities, either at or below the soil surface, will limit the infiltration rate, especially the basic infiltration rate. In addition, surface crusts, silt deposits, surface cracking, plow layers or clay layers will have a major effect on infiltration.

Infiltration rates are affected by the vegetative cover on the soil surface. Infiltration rates on grass land are substantially higher than for bare uncultivated land. Additions of organic matter increase infiltration rate substantially.

The increase in depth of water increases the water pressure at the surface and consequently increases the infiltration rate.

Due to the variability of those factors, care must be taken in choosing locations for infiltration measurements in order for the results to be representative and meaningful. Several measurements are required to achieve a reliable estimate of the infiltration rate for a field. Suggest 4 to 5 measurements.

4.3 Infiltration Equation

Several mathematical relationships or models have been proposed for infiltration rate and cumulative infiltration. But the most often use is Kostiaikov-Lewis equation:

$$D = At^B \dots\dots\dots (10)$$

where

D = cumulative infiltration, cm.,

t = elapsed time, min.,

A, B = characteristic constants (usually range from
0 to 1)

The instantaneous infiltration rate at any time 't' after the start of irrigation may be obtained by differentiating the cumulative infiltration equation. From Equation (10), we get:

$$I = \frac{dD}{dt} = ABt^{B-1} \dots\dots\dots (11)$$

where

I = instantaneous infiltration rate, cm./min.

4.4 Determination of Infiltration

Several methods can be used to determine the infiltration characteristics of a soil under field conditions. Methods frequently used for basin and border irrigation are:

- (1) Cylinder (ring) infiltrometer, and
- (2) Basin infiltrometer.

The two common methods used for furrow irrigation are:

- (3) Blocked furrow infiltrometer, and
- (4) Inflow-outflow measurements on a segment of a furrow.

The cylinder infiltrometer technique which is the most common use is the only method to be discussed here. The measurement of infiltration rate for furrow irrigation will be discussed later under the topic "Surface irrigation techniques".

Cylinder Infiltration Method

The Cylinder or ring infiltrometer (Fig.6) is a metal cylinder which is driven into the soil. It measures primarily the vertical

rate of water movement into the soil surface (one-dimensional) from the pond it encloses. Cylinder infiltrometer infiltration data are obtained by measuring the depth of ponded water inside the cylinder at time intervals.



Figure 6 Cylinder infiltrometer in use.

After water penetrates the soil to the depth of the bottom of the cylinder, it will begin to spread radially as well as vertically and the infiltration rate will change accordingly. Buffer ponds surrounding the cylinder are used to minimize this effect. Buffer ponds can be constructed by forming an earthen dike around the cylinder or by driving a larger diameter cylinder into the soil concentric with the cylinder infiltrometer. Water is maintained in the area between the two cylinders at about the same depth as that in the inner cylinder.

Two problems may make infiltration rates measured by cylinder infiltrometers unrepresentative of true infiltration rates. One is that the soil may be disturbed when the rings are driven into the ground. The second is that the ponded water may not duplicate real conditions. For example, although infiltration rates are not too sensitive to the

water pressure at the surface, or equivalently the depth of water on the surface, water pressure will have some effect. The infiltration rate measured with an infiltrometer with 20 cm. of ponded water will not be equivalent to that in a border with 5 cm. water depth, or to that under a sprinkler where no water is ponded. Also, air which is trapped under a level basin may escape laterally from around the infiltrometer. Finally, under real conditions, water usually moves across the soil surface rearranging surface particles. This erosion and aggregation which does not occur in ponded infiltration tests tends to seal soil surfaces and reduce infiltration rates.

A. Equipments

1. A cylinder infiltrometer 30 to 50 cm. in diameter and 30 to 40 cm. in length, made of smooth steel, rigid enough to allow it to be driven into the ground, but still thin enough to enter the soil with minimum disturbance. Two millimeter thick (14 gauge) steel will usually work, but may need reinforcement around the upper edge. The larger the diameter of the cylinder and the deeper the cylinder penetrates the soil, the less will be the edge effects and the greater will be the accuracy of the measurements.

2. A buffer cylinder having a diameter at least 30 cm. greater than the infiltrometer and a length of about 20 cm. Construction should be similar to that of the infiltrometer. Sections of 55 gallon drums can be used as buffer cylinders. Alternately, the buffer "ring" can be a diked area surrounding the cylinder infiltrometer.

3. A water level gauge for measuring the changes of water level in the cylinder infiltrometer. A simple hook gauge is shown in Figure 3, although other arrangements are possible.

4. Equipment for installing the cylinders such as a metal plate or heavy timber and a sledge hammer.

5. A plastic sheet or other waterproof membrane.

6. Source of water (about 200 liters)

7. Bucket

Also: watch.

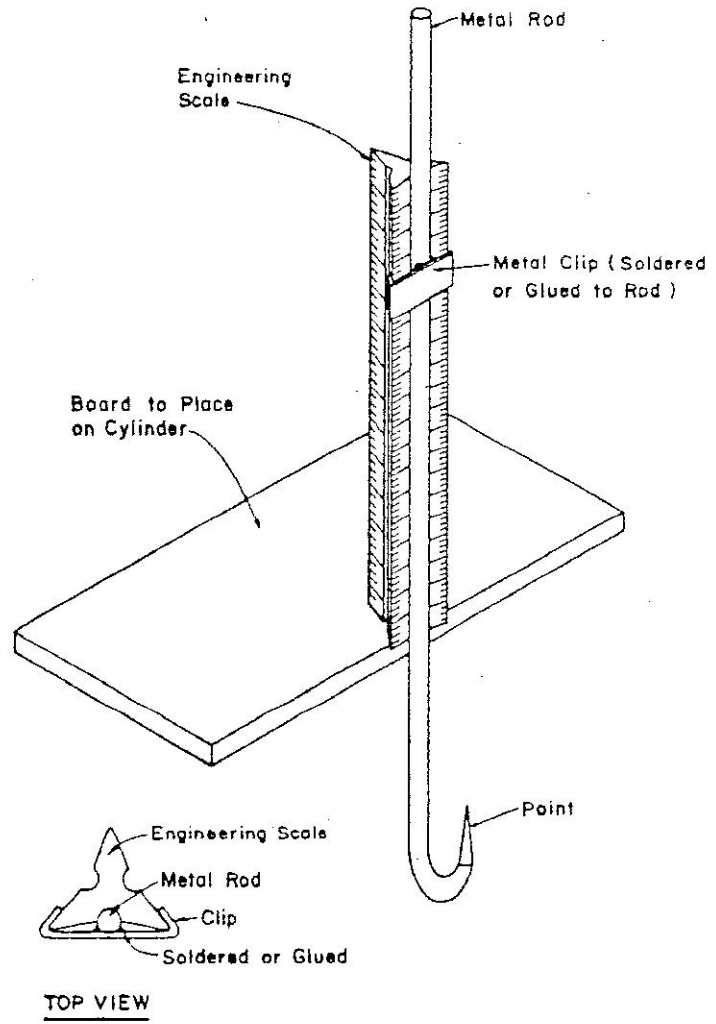

Figure 7 Hook gauge for cylinder infiltrometer

B. Installation Procedure

1. Select a representative location and examine carefully for signs of unusual surface disturbances, such as stones that might damage cylinders, cracks which might give nonrepresentative readings, etc. Avoid areas that may have been affected by unusual animal or machinery traffic. Note the soil type and condition (tillage, vegetation, moisture).

2. Drive the infiltrometer cylinder to a depth of at least 15 cm. The cylinder should be installed as vertically as possible. This can be assured by checking the alignment frequently during the installation procedure. Do not drive the cylinder into the soil irregularly so that first one side then the other goes down. This procedure produces poor contact between the cylinder wall and the soil, and may disturb the soil core within the cylinder. If the cylinder gets out of alignment while driving, remove it and reset it in a comparable area nearby.

3. Set the buffer cylinder around the infiltrometer and drive it into the soil. This outside cylinder need not be driven as deep as the cylinder infiltrometer--generally, 5 to 10 cm. into the soil will be adequate.

4. Place a plastic sheet or other waterproof membrane on the soil within the cylinder infiltrometer so that it forms an inner cylinder to hold the water. The plastic should be in contact with the soil at the bottom of the infiltrometer and extend up the walls of the infiltrometer at least 15 cm.

5. Fill the buffer pond with water to a depth roughly equal to the depth desired in the inner ring. Maintain roughly equivalent depths throughout the period of observation.

6. Fill the cylinder infiltrometer with water to a depth of about 10 cm. In extremely porous (high intake) soils, a greater depth may be needed.

7. Place the hook gauge board on the cylinder and set the point of the gauge at the water level. Read the scale from the top edge of the clip. This is the initial depth reading and will correspond to

the initial time reading.

8. Quickly, but gently, remove the plastic membrane recording the time at which this is done. This is the initial time reading. Make a hook gauge reading as soon as the water surface is still enough to do so, and compare this reading to the initial one to insure that there were no air spaces below the plastic.

9. Make additional hook gauge readings at periodic intervals and record the hook gauge and time readings. Intervals between observations should be short (2 to 5 min.) at the start of the test. After 20 minutes the intervals may be increased to 10 to 20 min. After about 2 hours, measurements made at 30 to 50 minute intervals will usually be sufficient.

10. When the water level has dropped 4 to 5 cm. in the cylinder infiltrometer, carefully add a sufficient volume of water to return the water surface to the approximate initial level. The known volume of water added, divided by the crosssectional area of the cylinder, gives the depth of water added to the cylinder. If a volumetric container is not available, the added depth can be closely estimated by the depth readings just before and after the water was added. The volume added and corresponding depth added, or the estimated depth added should be recorded on the data collection sheet.

11. Where abnormally high or low infiltration values are indicated by the test results, the infiltrometer should be dug out and the soil examined for possible causes. If, while running the test, an obvious cause for a high rate of infiltration can be seen, such as water rising outside the cylinder, the test should be terminated immediately and the cylinder moved to a nearby location and reinstalled.

12. The measurements should be continued until the change in depth over time becomes fairly constant. The time required will generally vary from 3 to 6 hours, depending on the preexisting moisture conditions and soil hydraulic conductivity.

C. Analysis

The infiltrated depths over time were measured as tabulated in

Table 3 Infiltration Test

1. Location PLOT-A1, Observer Mr.X, Date 9/26/86
 2. Crop CORN, Root zone depth 100 cm.
 3. Soil: texture SANDY CLAY LOAM
 4. Crop history: PLANTING DATE 7/1/86
 5. Remarks:

6.

| Cylinder | | | 1 | | |
|-----------------|-------|-------|---------------------|-------|-------|
| Time minutes | | | Infiltration cm. | | |
| watch | diff | cumu | depth | diff | cumu |
| 10:55 | | 0 | 6.3 | | 0 |
| | 1 | | | 0.3 | |
| 56 | | 1 | 6.6 | | 0.3 |
| | 3 | | | 0.5 | |
| 59 | | 4 | 7.1 | | 0.8 |
| | 2 | | | 0.1 | |
| 11:01 | | 6 | 7.2 | | 0.9 |
| | 4 | | | 0.4 | |
| 05 | | 10 | 7.6 | | 1.3 |
| | 12 | | | 0.8 | |
| 17 | | 22 | 8.4 | | 2.1 |
| | 9 | | | 0.4 | |
| 26 | | 31 | 8.8 | | 2.5 |
| | 12 | | | 0.3 | |
| 38 | | 43 | 9.1 | | 2.8 |
| | 25 | | | 1.1 | |
| 12:03 | | 68 | 10.2 | | 3.9 |
| | 18 | | | 0.2 | |
| 21 | | 86 | 10.4 | | 4.1 |
| | 18 | | | 0.6 | |
| 39 | | 104 | 11.0 | | 4.7 |
| | 41 | | | 1.2 | |
| 1:20 | | 145 | 12.2 | | 5.9 |
| | 38 | | | 1.3 | |
| 58 | | 183 | 13.5 | | 7.2 |
| | | | | | |

Table 3. The elapsed time (t) and the corresponding cumulative infiltration (D) were calculated. The infiltration data should be first fitted by Equation 10. This can be done graphically using log-log paper.

A power curve of form

$$D = At^B$$

will plot as a straight line on log-log paper with

B as the slope of the line

and A as the D value at t = 1.

The plot of D against t on log-log paper shows a straight line as shown in Figure 8. Thus the cumulative infiltration of Table 3 can be expressed as ;

$$D = 0.37 t^{0.56} \dots\dots\dots (12)$$

and the infiltration rate can be expressed as

$$I = 0.37 \times 0.56 t^{-0.44} \text{ cm./min.}$$

or $I = 60 \times 0.37 \times 0.56 t^{-0.44} \text{ cm./hr.}$

$$= 12.43 t^{-0.44} \text{ cm./hr.} \dots\dots\dots (13)$$

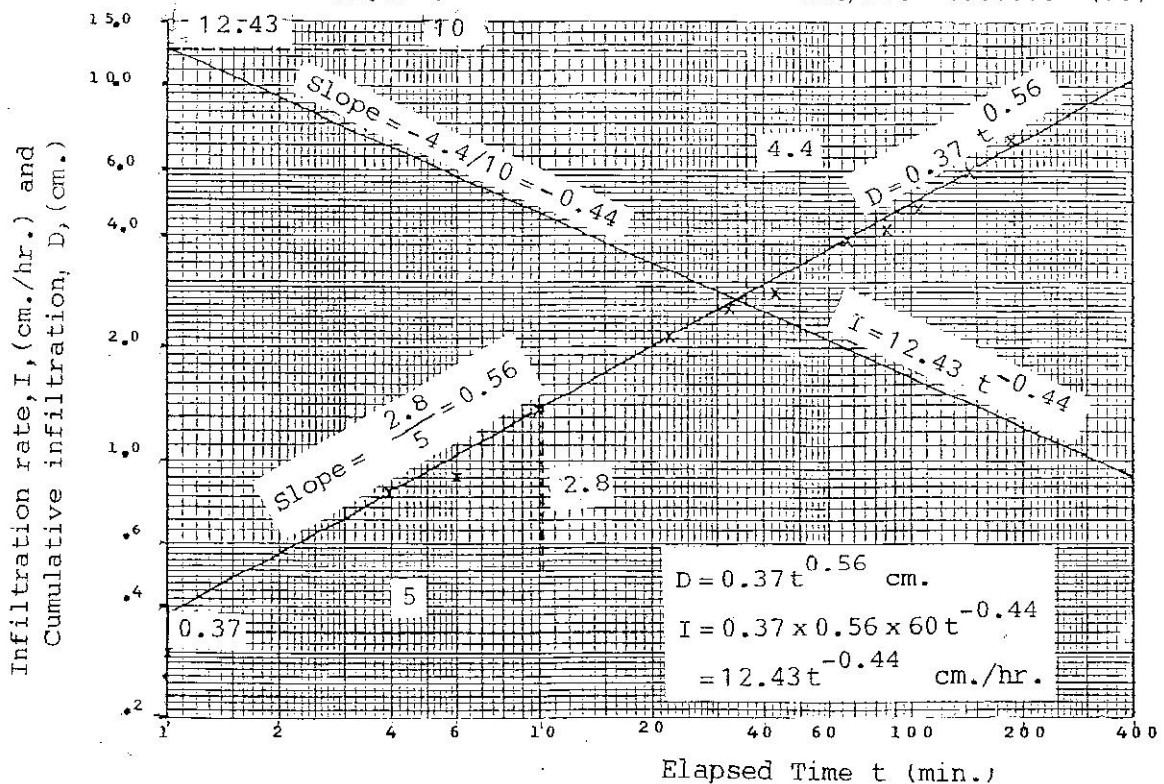

Figure 8 Infiltration rate and cumulative infiltration curves

Figure 8 will help determine the intake opportunity time required for applying a certain amount of water into the soil and also can give the infiltration rate of the soil at any time after the start of irrigation.

Example 6

(1) Determine the infiltration rate of Plot A1 at 1 and 2 hours after irrigation.

From Figure 8, I at 60 minutes = 2.1 cm./hr.

I at 120 minutes = 1.5 cm./hr.

(2) Determine the intake opportunity time for 6.0 cm. of water.

D = 6 cm.

From Figure 8,

t = 145 minutes.

Training Course on Irrigation Design and Management
(August 87)

Exercise No. 1

Soil-Water-Plant Relationships

1. In collecting an undisturbed soil sample from Plot No.1 using a soil core sampler, the ring of 5.00 cm. in diameter, 5.00 cm. high and 40 gm. of weight was used. The weight of soil sample and ring was 180 gm. After kept in oven at 105°C for 24 hours, the soil sample and ring weighed 150 gm. Determine the apparent specific gravity of the soil and the soil moisture in % on dry weight and volumetric basis.

2. The soil sample in (1) was send to a laboratory for determining the field capacity and permanent wilting point. It was found that the field capacity and the permanent wilting point of the soil in Plot No. 1 are 30 and 18 % on dry weight basis respectively. Determine the available moisture of the soil in term of % on dry weight basis, % on volumetric basis and the ratio of depth of water to depth of soil, and calculate the moisture of the soil sample in term of % of available moisture.

3. The mung bean is grown in Plot No. 1. The general characteristics of the mung bean are given below:

| | | |
|-----------------------------|---|----------------------------|
| the rooting depth | = | 50 cm. |
| the consumptive use | = | 4 mm./day |
| the critical moisture level | = | 30 % of available moisture |

Determine

- (1) the allowable depletion in term of % on dry weight basis,
- (2) the net depth of irrigation water to be applied in each irrigation in mm.,
- (3) the gross volume of water to be applied, if the water application efficiency is 60 % and the area of Plot No. 1 is 10 hectares.

(4) the irrigation frequency

(5) if the source of water supply comes from a pump well which has the pumping capacity of $30 \text{ m}^3/\text{hr.}$ and can operate 8 hours per day, determine whether the pumping capacity is adequate to irrigate the whole area of Plot No. 1 (10 ha.). If not adequate, what would you suggest to increase the pumping capacity to satisfy the irrigation water requirement of Plot No. 1.

4. The soil in Plot No. 2 which grows corns has the field capacity and permanent wilting point of 25 and 15 % on dry weight basis respectively. Its apparent specific gravity is 1.4.

The determination of soil moisture of Plot No. 2 was made, on August 1, 87 throughout the root zone depth of 90 cm. The following data were obtained:

| | |
|---|--------------|
| weight of moist soil including container | = 180.04 gm. |
| weight of oven dry soil including container | = 152.84 gm. |
| weight of container | = 42.2 gm. |

If the critical point is 50 % of available moisture, determine,

(1) Is irrigation needed on August 1 ?

(2) If the consumptive use of crop is 6 mm./day, what is the date to irrigate.

(3) The irrigation frequency.

5. The field measurements of infiltration by double ring infiltrometer gave the data as shown in the following table.

| Time - Minutes | | | Infiltration - mm. | | |
|----------------|-------|------------|--------------------|-------|------------|
| Watch | Diff. | Cumulative | Depth * | Diff. | Cumulative |
| (1) | (2) | (3) | (4) | (5) | (6) |
| 8:00 | | | 0 | | |
| 10 | | | 44 | | |
| 20 | | | 70 | | |
| 30 | | | 89 | | |
| 45 | | | 111 R | | |
| 9:00 | | | 20 | | |
| 30 | | | 56 | | |
| 10:00 | | | 85 R | | |
| 11:00 | | | 48 | | |
| 13:00 | | | 124 | | |

* Measured from the top of ring

R. Refilled to zero reading.

Plot the cumulative infiltration depth versus time on log-log paper and determine the equation for cumulative depth and infiltration rate.

If it is desired to irrigate 100 mm. of water by flooding method, what will be the time required for water to stand on the surface? What are the infiltration rates at 15 minutes and 2 hours after applying the water?

 LOGARITHMIC
3 X 3 CYCLES
46 7403
MADE IN U.S.A.
KEUFFEL & ESSER CO.

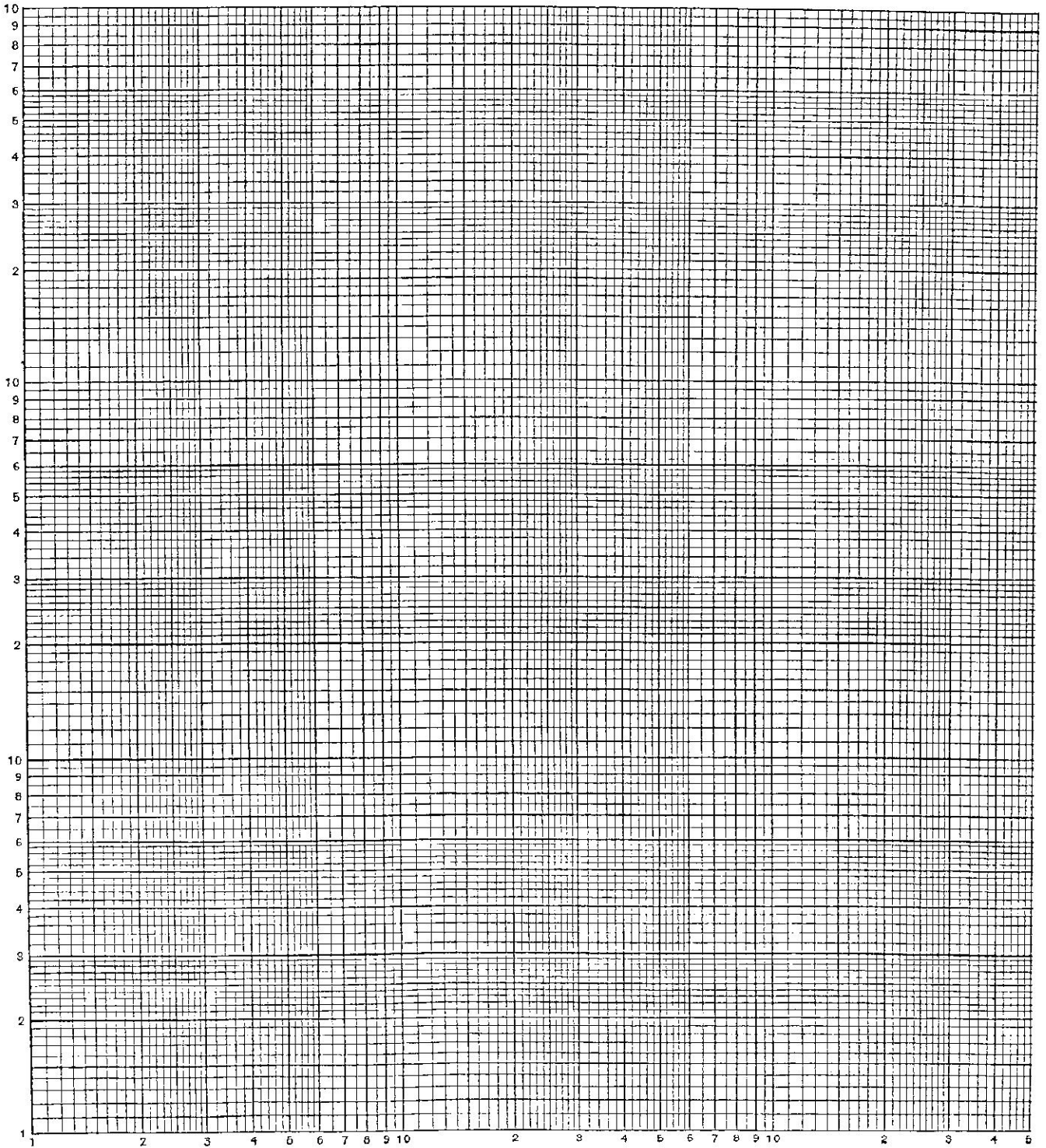

Training Course on Irrigation Design and Management

(August 87)

Solution to Exercise No.1

Soil-Water-Plant Relationships

1. Data of the soil sample collected from Plot No. 1 are :-

$$\begin{aligned} \text{volume of ring (V)} &= \frac{\pi}{4}(5.0)^2 \times 5.0 && \text{cm.}^3 \\ &= 98.175 && \text{"} \\ \text{weight of ring} &= 40 && \text{gm.} \\ \text{weight of moist soil plus ring} &= 180 && \text{"} \\ \text{weight of oven-dry soil plus ring} &= 150 && \text{"} \end{aligned}$$

Calculation

$$\begin{aligned} \text{weight of oven-dry soil (W}_s) &= 150 - 40 && \text{"} \\ &= 110 && \text{"} \\ \text{weight of moisture in soil (W}_w) &= 180 - 150 && \text{"} \\ &= 30 && \text{"} \\ \text{water density (}\gamma_w) &= 1 \text{ gm./cm.}^3 \\ \text{Apparent specific gravity (A}_s) &= \frac{W_s}{V \gamma_w} \\ &= \frac{110}{98.175 \times 1} \\ &= 1.120 \\ \text{\% of moisture on dry weight basis (P}_w) &= \frac{W_w}{W_s} \times 100 \end{aligned}$$

$$= \frac{30}{110} \times 100$$

$$= 27.27$$

% of moisture on volumetric basis (P_v)

$$= \frac{V_w}{V} \times 100$$

or

$$= P_w \cdot A_s$$

$$= 27.27 \times 1.120$$

$$= 30.54$$

2. Data (Soil of Plot No.1)

Field capacity (P_w) = 30

permanent wilting point (P_w) = 18

Calculation

available moisture (P_w) = 30 - 18

$$= 12$$

available moisture (P_v) = 12 x 1.12

$$= 13.44$$

available moisture ($\frac{d}{D}$) = $\frac{P_v}{100}$

$$= \frac{13.44}{100}$$

$$= 0.1314 \text{ cm. of water/ cm. of soil}$$

Soil moisture content = $\frac{27.27 - 18}{12} \times 100 = 77.25$ % available M.

3. Data (Mung bean in Plot No.1)

rooting depth = 50 cm.

consumptive use = 4 mm./day

critical moisture level = 30 % of available moisture

Determine

$$\begin{aligned} (1) \text{ allowable depletion} &= 100-30 \text{ \% of available moisture} \\ &= 70 \text{ "} \end{aligned}$$

$$\begin{aligned} (2) \text{ net depth of irrigation water} &= \text{allowable depletion from the} \\ &\quad \text{root zone of mung bean} \\ &= \frac{70}{100} \times 0.1344 \times 50 \text{ cm.} \\ &= 4.7 \text{ "} \\ &= 47 \text{ mm.} \end{aligned}$$

$$\begin{aligned} (3) \text{ total depth of irrigation water} &= \frac{\text{net depth}}{\text{application efficiency}} \text{ mm.} \\ &= \frac{47}{0.60} \text{ "} \\ &= 78.3 \text{ "} \end{aligned}$$

$$\text{the area of plot No.1} = 10 \text{ hectares}$$

$$\begin{aligned} \text{gross volume of water to be applied} &= \text{total depth} \times \text{area} \\ &= \frac{78.3}{1000} \times 10 \times 10,000 \text{ m}^3 \\ &= 7830 \text{ "} \end{aligned}$$

$$\begin{aligned} (4) \text{ irrigation frequency} &= \frac{\text{net depth}}{\text{consumptive use}} \\ &= \frac{47}{4} \text{ days} \\ &= 11.75 \text{ "} \\ &= \underline{\text{Use 11.}} \text{ "} \end{aligned}$$

(5) According to the designed irrigation frequency of 11 days,
the area to be irrigated in each day

$$= \frac{10}{11} = 0.91 \text{ hectares}$$

the net depth to be applied

$$= \text{consumptive use} \times \text{irrigation frequency}$$

$$= 4 \text{ mm./day} \times 11 \text{ days}$$

$$= 44 \text{ mm.}$$

the total depth

$$= \frac{44}{0.60} \text{ mm.}$$

$$= 73.3 \text{ mm.}$$

$$\text{gross volume} = \frac{73.3}{1,000} \times 0.91 \times 10,000 \text{ m}^3$$

$$= 667.0$$

$$\text{If working hours} = 8 \text{ hr./day}$$

Thus, the required pumping rate

$$= \frac{667}{8} \text{ m}^3/\text{hr.}$$

$$= 83.4 \text{ "}$$

The well pumping capacity of 30 m³/hr. with 8 working hours per day is not adequate to satisfy the water requirements of 10 hectares of mung bean in Plot No. 1.

Suggest to use 83.4 m³/hr. with 8 working hours a day or 30 m³/hr. with 22.2 working hours a day.

4. Data

Growing corns in Plot No. 2

field capacity (P_w) = 25

permanent wilting point (P_w) = 15

As = 1.4

root zone depth (D) = 90 cm.

critical point = 50 % of available moisture

Soil moisture determination data

Sampling date : August 1, 87

weight of moist soil plus container = 180.04 gm.

weight of oven dry soil plus container = 152.84 "

weight of container = 42.2 "

$$\begin{aligned} \text{Soil moisture } (P_w) &= \frac{W_w}{W_s} \times 100 \\ &= \frac{180.04 - 152.84}{152.84 - 42.2} \times 100 \\ &= 24.58 \end{aligned}$$

Determine

$$\begin{aligned} (1) \text{ Available moisture } (P_w) &= 25 - 15 \\ &= 10 \end{aligned}$$

Soil moisture at critical point (P_w)

$$\begin{aligned} &= \text{permanent wilting point } (P_w) + \% \text{ of available} \\ &\quad \text{moisture at critical point } (P_w) \\ &= 15 + \frac{50}{100} \times 10 = 20 \end{aligned}$$

Soil moisture (P_w) on August 1, 87

$$= 24.58 \text{ (almost at field capacity)}$$

Thus, irrigation is not yet needed.

(2) The remaining moisture in corn root zone before irrigation

$$= \frac{P_w \cdot A_s \cdot D}{100}$$

$$= \frac{(21.58 - 20) \times 1.4 \times 90}{100} \text{ cm.}$$

$$= 5.77 \text{ "}$$

$$= 57.7 \text{ mm.}$$

$$\text{Consumptive use of corn} = 6 \text{ mm./day}$$

$$\text{The date to irrigate} = \text{August 1} + \frac{57.7}{6}$$

$$= \text{August 10}$$

(3) Allowable depletion (P_w)

$$= \text{field capacity} - \text{critical point}$$

$$= 25 - 20$$

$$= 5$$

$$\text{Allowable depletion} = \frac{5 \times 1.4 \times 90}{100} \text{ cm.}$$

$$= 6.3 \text{ "}$$

$$= 63 \text{ mm.}$$

$$\text{consumptive use fo corn} = 6 \text{ mm./day}$$

$$\text{irrigation frequency} = \frac{\text{allowable depletion}}{\text{consumptive use}}$$

$$= \frac{63 \text{ mm.}}{6 \text{ mm./day}}$$

$$= 10.5 \text{ days}$$

$$= \underline{\text{Use 10 days}}$$

5.

| Time - minutes | | | Infiltration - mm. | | |
|----------------|-------|------------|--------------------|-------|------------|
| Watch | Diff. | Cumulative | Depth | Diff. | Cumulative |
| (1) | (2) | (3) | (4) | (5) | (6) |
| 8:00 | | 0 | 0 | | 0 |
| | 10 | | | 44 | |
| 10 | | 10 | 44 | | 44 |
| | 10 | | | 26 | |
| 20 | | 20 | 70 | | 70 |
| | 10 | | | 19 | |
| 30 | | 30 | 89 | | 89 |
| | 15 | | | 22 | |
| 45 | | 45 | 111 R | | 111 |
| | 15 | | | 20 | |
| 9:00 | | 60 | 20 | | 131 |
| | 30 | | | 36 | |
| 30 | | 90 | 56 | | 167 |
| | 30 | | | 29 | |
| 10:00 | | 120 | 85 R | | 196 |
| | 60 | | | 48 | |
| 11:00 | | 180 | 48 | | 244 |
| | 120 | | | 76 | |
| 13:00 | | 300 | 124 | | 320 |

1,000

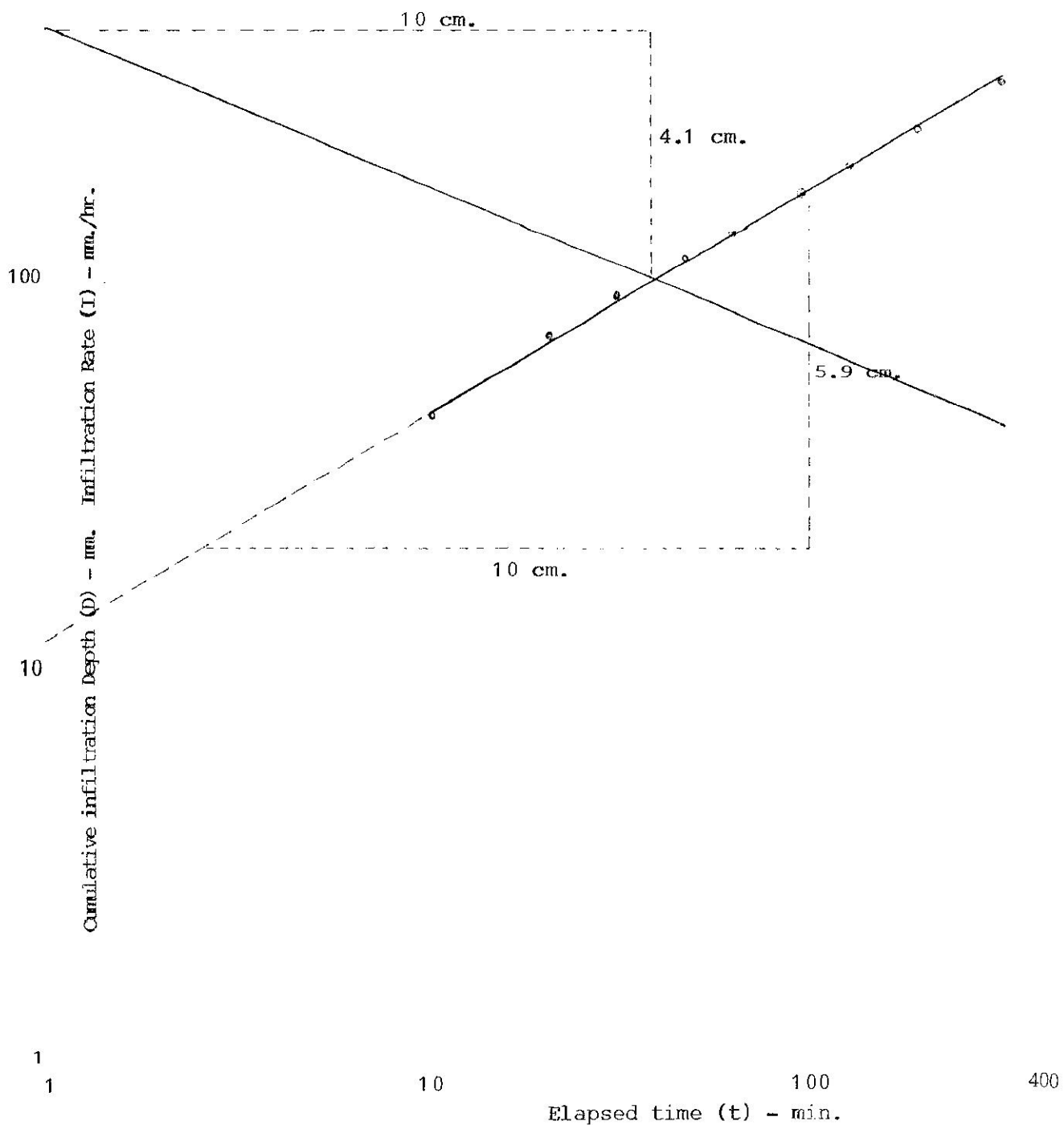

Plot the cumulative infiltration depth vs. time.

From the plot of D VS. t on log-log paper, we obtain that

$$D \text{ (mm.)} = 11.8 t^{0.59} \dots\dots\dots (1)$$

$$\begin{aligned} I \text{ (mm./min.)} &= \frac{dD}{dt} \\ &= \frac{d}{dt} 11.8 t^{0.59} \\ &= 11.8 \times 0.59 t^{0.59-1} \\ &= 6.962 t^{-0.41} \\ I &= 60 \times 6.962 t^{-0.41} \text{ mm./hr.} \\ &= 417.72 t^{-0.41} \text{ mm./hr.} \dots\dots\dots (2) \end{aligned}$$

Determine

The opportunity time for applying 100 mm. or water

$$\begin{aligned} D &= 11.8 t^{0.59} \\ 100 &= 11.8 t^{0.59} \\ t &= \left(\frac{100}{11.8} \right)^{\frac{1}{0.59}} \\ &= 37.4 \text{ min.} \end{aligned}$$

The infiltration rates of this soil at 15 minutes and 2 hours after applying water,

$$\begin{aligned} I &= 417.72 t^{-0.41} \\ \underline{t = 15 \text{ min.}} \\ I &= 417.72 (15)^{-0.41} \text{ mm./hr.} \\ &= 137.6 \text{ "} \end{aligned}$$

t = 120 min. (2 hours)

$$\begin{aligned} I &= 417.72 (120)^{-0.41} \text{ "} \\ &= 58.7 \text{ "} \end{aligned}$$

IRRIGATION DESIGN AND MANAGEMENT
TRAINING COURSE
Package II : IRRIGATION PRINCIPLES

By

THE ROYAL IRRIGATION DEPARTMENT
in cooperation with
KASETSART UNIVERSITY

AUGUST 1987

Training Course : IRRIGATION DESIGN AND MANAGEMENT
(Irrigation Principles)

EVAPOTRANSPIRATION AND IRRIGATION WATER REQUIREMENTS

By

Dr. Varawoot Vudhivanich

Assistant Professor

Dept. of Irrigation Engineering
Kasetsart University

Faculty of Engineering
Kamphaengsaen Campus

Nakorn Pathom 73140

Contents

| | | |
|------|---|----|
| 1. | Introduction | 1 |
| 2. | Crop Water Requirement (ET_c) | 1 |
| 3. | Factors Affecting ET_c | 2 |
| 3.1 | Climatic Factors | 2 |
| 3.2 | Soil Factors | 4 |
| 3.3 | Plant Factors | 4 |
| 3.4 | Cultural Factors | 4 |
| 4. | Direct Measurement of ET_c | 5 |
| 4.1 | Soil Moisture Studies | 5 |
| 4.2 | Water Balance Method | 5 |
| 4.3 | Lysimeter Measurements | 6 |
| 5. | Calculations of Reference Crop Evapotranspiration | 10 |
| 5.1 | The Blaney-Criddle Formula | 13 |
| 5.2 | Radiation Method | 17 |
| 5.3 | Penman Method | 23 |
| 5.4 | Evaporation Method | 29 |
| 6. | Determination of Evapotranspiration | 32 |
| 6.1 | Crop Coefficients | 32 |
| 6.2 | Calculation of Evapotranspiration | 42 |
| 7. | Net Irrigation Requirements | 42 |
| 8. | Effective Rainfall | 43 |
| 8.1 | Effective Rainfall for field and vegetable crops | 44 |
| 8.2 | Effective rainfall for paddy field | 44 |
| 9. | Leaching Requirement | 46 |
| 10. | Water Requirements for Paddy Field | 48 |
| 10.1 | Percolation Loss | 48 |
| 10.2 | Land preparation | 48 |
| 10.3 | Nursery bed | 48 |
| 11. | Irrigation Efficiency | 49 |
| | References | 53 |

Evapotranspiration and Irrigation

Water Requirements

1. Introduction

The irrigation water requirement is one of the most important parameters for planning, designing and operation of irrigation systems. Incorrect estimation of the requirements will result in wrong design capacity of the water distribution system, operational problems and, consequently, low overall performance of the systems.

Irrigation water requirements consists of many components which can be identified as follows:

- (1) Crop water requirement or evapotranspiration (ET_c).
- (2) Requirement for maintaining salt balance in the root zone or leaching requirement (LR).
- (3) Requirements for other related activities such as land preparation, nursery, control of crops environment during severe weather conditions, spraying chemicals, etc.
- (4) Requirements for losses in conveying and applying water to the crops.

2. Crop Water Requirement (ET_c)

The terms "crop water requirement, evapotranspiration and consumptive use" have been used synonymously. They mean "the depth of water needed to meet the water losses through evaporation and transpiration of a disease-free crop, growing in a large field under non restricting soil conditions including soil water and fertility and achieving full production potential under the given growing environment" (Doorenbos and Pruitt, 1984).

By definition, the crop water requirement is the sum of two terms; (1) transpiration, which is the amount of water entering plant roots and used to built plant tissues and the excess is passed through

leaves of plant into the atmosphere, (2) evaporation, which is water evaporating from the soil, water surfaces and plant canopy wetted by dew, rainfall or irrigation. Schematic sketch of terms representing evapotranspiration components is presented in Fig. 1.

Crop water requirements are usually expressed in terms of depth per unit of time such as mm/day, mm/month or in other similar units.

3. Factors Affecting ET_c

The evapotranspiration rate of crops is affected by many factors which can be classified into four main groups; (1) climatic factors, (2) soil factors, (3) plant factors, and (4) cultural factors.

3.1 Climatic Factors The climatic factors which influence the evapotranspiration rates are those that can be converted to energy available and induced vapor pressure gradient on the plant and soil surfaces. To evaporate 1 gram of water at 20°C. it requires heat energy of approximately 585 calories. Generally, the climatic factors controlling ET_c rates are:

- (1) Net solar radiation, (R_n) which is affected by the incoming solar radiation (R_s), cloud cover, angle of the sun's radiation which depends on season, time of the day, latitude and slope of the land, the properties of evaporating surfaces, etc.
- (2) Relative humidity of the air moving over the surfaces.
- (3) The velocity and turbulence of the air.
- (4) Temperature of the air relative to surrounding temperature of plant canopies.

Factor (1) determines the main energy source available directly from the sun. Additional of this may come from stored heat in the moving air mass. The low humidity and turbulent wind increase vapor pressure gradient and transport capability of the air which results in more water losses from the cropping area.

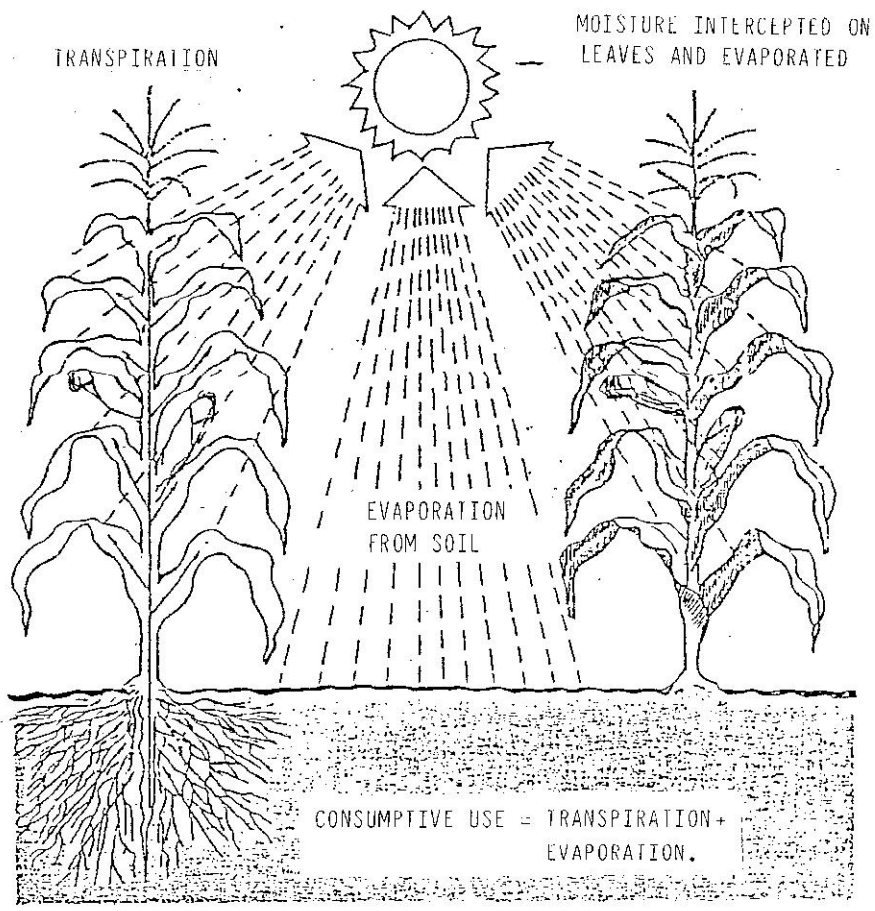

Fig. 1 Schematic sketch of terms representing evapotranspiration components.

3.2 Soil Factors The most important soil factor affecting crop evapotranspiration rate is the amount of available water in the root zone. When the soil moisture is at or near field capacity, the plant usually can obtain water from the soil fast enough to satisfy evaporative demand dictated by climatic conditions. As the soil moisture decreases close to permanent wilting point, it becomes more difficult for the roots to obtain water for transpiration. Under this condition, the crop evapotranspiration rate will be controlled by the area at which plant roots extract water from the soil.

Transpiration rate can also be influenced by soil temperature, high salts and toxic concentration of the soil.

3.3 Plant Factors The plant factors influencing evapotranspiration can be divided into three categories: (1) aerodynamic roughness of the plant which relates to geometry and stiffness of the plant canopies, uniformity of the top surface of plant population, etc. These properties influence the efficiency of water vapor removal and absorbing heat energy from the moving air mass, (2) degree of ground covers and plant population which account for interception of solar energy and the relative size of sustaining evaporating surface, (3) the root density and distribution which control the rate at which plant can extract moisture from the soil and transport to plant leaves, and (4) stomatal resistance to the flow of water vapor to the atmosphere. All plant factors depend upon the kind of plants and their stage of development.

3.4 Cultural Factors The cultural factors influencing evapotranspiration are those related to evaporation from the soil and plant surfaces and transpiration by vegetation. Frequent irrigations increase evaporation loss. Sprinkler irrigation which thoroughly wet the soil and plants losses more water by evaporation than furrow or trickle irrigation. On the other hand, reduction of the losses from soil surface during the early stage of crop development can be done by surface mulching, shading, tillage and weeding.

4. Direct Measurement of ET_c

There are several methods for direct determination of crop evapotranspiration. The principal methods are soil moisture studies, water balance and, lysimeter measurements.

4.1 Soil Moisture Studies Average crop evapotranspiration can be determined by observing changes in soil moisture content over a period of time. Soil moisture measurements taken at two different dates are used to determine the change of soil moisture. The average rate of evapotranspiration between the date can be calculated using the equation:

$$ET_c = \frac{W_{et}}{\Delta t} = \frac{\sum_{i=1}^n (\theta_1 - \theta_2)_i \Delta S_i + R_e - W_d}{\Delta t} \dots\dots\dots (1)$$

- where W_{et} = the total water used by evapotranspiration.
 Δt = time interval between the two sampling dates.
 n = total number of layers through the depth of effective root zone.
 θ_1, θ_2 = the volumetric soil moisture content of the same soil layer on the first and second sampling dates respectively.
 ΔS = the thickness of each soil layer.
 R_e = the effective rainfall, the amount of rainfall which infiltrated into the soil.
 W_d = drainage from (+) or upward flow to (-) the zone root.

Reliable of ET_c determined by this method require adequate precautions on determination of representative sampling sites and number of samples, determination of effective rainfall and drainage or upward flow past the bottom of the zone sampled. This method is so labourious and time consuming that at present most investigators changed to a more convenient and reliable method of lysimeter measurement.

4.2 Water Balance Method The water balance method has been used for determination of long-term evapotranspiration in large area in

which the inflow and outflow are determined from rainfall and stream-flow measurements. The values of ET_C is calculated based on the water balance equation :

$$ET_C = P - (R + \Delta G + \Delta \theta) \dots\dots\dots(2)$$

where ET_C = crop evapotranspiration

P = precipitation

R = surface runoff from the watershed

ΔG = groundwater reservoir recharge or drainage

$\Delta \theta$ = change in soil moisture content

The method has, generally, been used mostly for water balance studies of well defined boundary of river basins. The calculated ET_C is only a gross estimated of average evapotranspiration of both cultivated and native crops.

4.3 Lysimeter measurements Lysimeters are tanks filled with soil in which crops are grown under natural conditions to measure the amount of water used by evaporation and transpiration. From technical point of view, lysimeters are developed only to enable the operator to measure accurately all components in the water balances equation i.e., water added by irrigation or rainfall, water retained by the soil, and losses by evapotranspiration and percolation. At present, lysimeters are considered to be the most reliable and widely used instrument for direct measuring crops evapotranspiration. However, their installation must meet the following requirements:

- (1) The lysimeter should be fairly large and deep to permit free growth of plant roots. In general, the soil volume should be at least one cubic meter for short rooted crops.
- (2) The crop covers and siting must be fully representative of the natural field conditions. The crop in the lysimeter should not either taller, shorter, denser or thinner or the lysimeter is located on the periphery of cropping area.

- (3) The physical conditions within the lysimeter such as soil texture, structure, moisture content, etc., must be comparable to those outside.
- (4) In order to minimize the heat advection effects, the lysimeter should be located at a sufficient distance from the upwind edge of the surrounding area.

There are many types of lysimeter being used at present. These can be grouped into two categories: (1) non-weighing types and (2) weighing lysimeters. The non-weighing lysimeters are those which water use rates are determined mainly from volumetric measurement of the inflow to and outflow from the lysimeter.

Some of the non-weighing lysimeters are:

- (1) Percolation or drainage type (Fig.2) which bottom of the tank is filled with gravel and a drainage pipe connected to collect and convey the drained water to the observation tank for measurements.

- (2) Constant water table type (Fig. 3) which water used by crops is supplied from a constant water table level controlled by float valve. The amount of water used by crops can be measured directly from the change in water level in the water supply tank.

- (3) Rice lysimeter (Fig. 4) which consists of four tanks, two of which are opened bottom. For each of the two opened and closed bottom tanks, one is planted to rice, the other without any crop. Water used by the crop is measured by the drop in water level in the tanks with hook gages. Each component of water requirements for paddy field: evaporation, transpiration, evapotranspiration and percolation can be calculated from the difference in water losses between two tanks which have one extra component of the requirement.

Generally, the non-weighing lysimeters are simple, and inexpensive, and no limitation on the size. However, the accuracy of measurements are less than the weighing types. They usually are used for long term measurements such as monthly or seasonal water requirements.

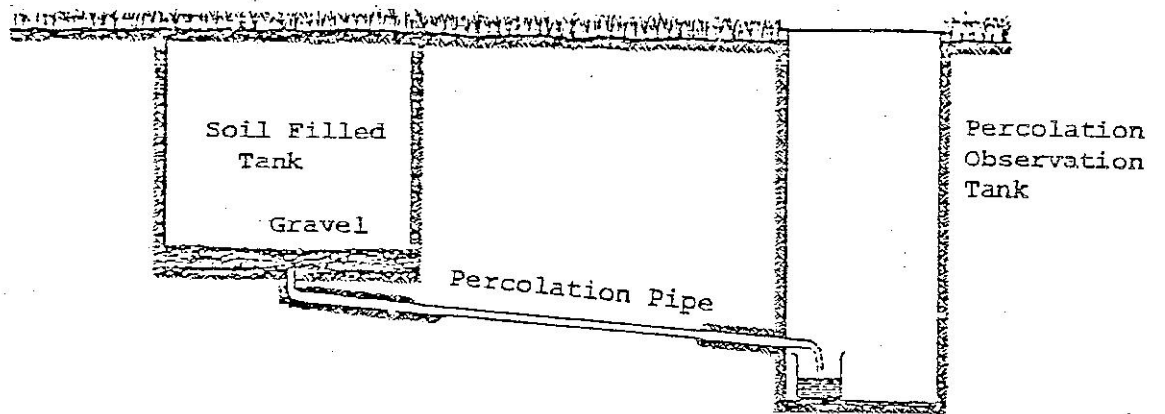
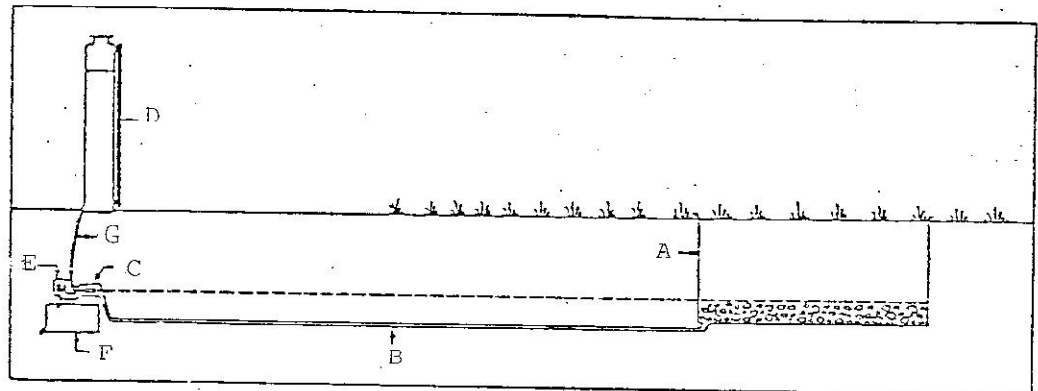

Fig. 2 Percolation type lysimeter



- | | |
|--------------------------------|-----------------------------|
| A. Evaporating tank | E. Overflow mechanism |
| B. Underground irrigation pipe | F. Overflow tank |
| C. Carburetor float valve | G. Connecting rubber tubing |

Fig. 3 Constant water table type lysimeter

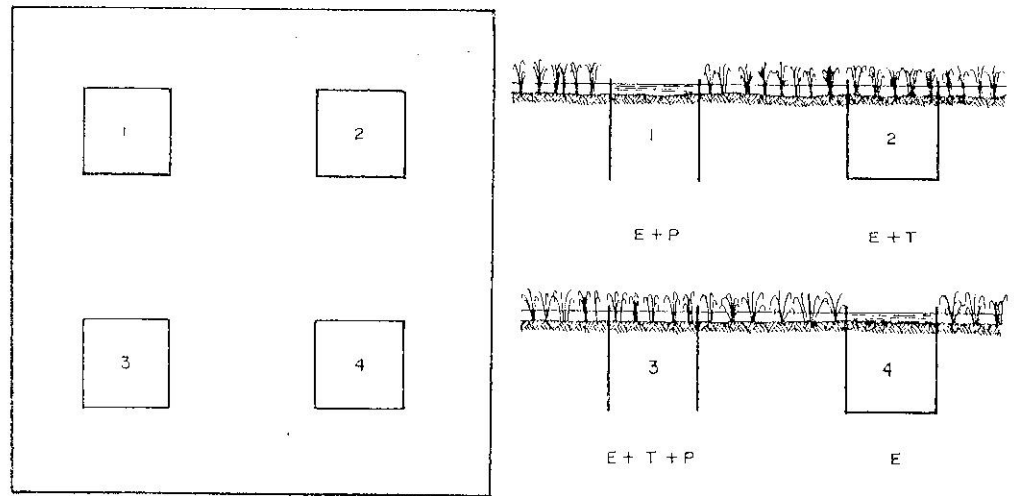

Fig. 4 Rice Lysimeter

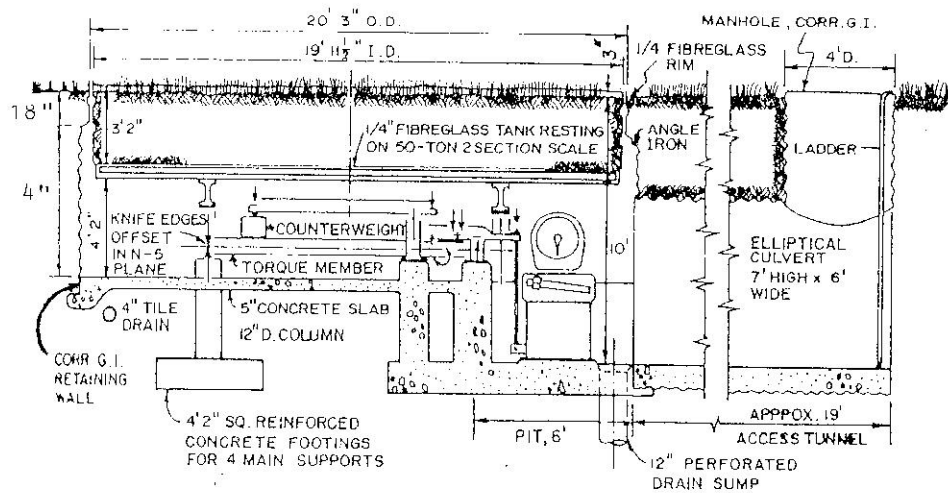

Fig. 5 Mechanically weight lysimeter of University of California at Davis

The weighing lysimeters determine the changes in soil water in the tanks directly with mechanical scale, load cell or hydraulic instrument. Some of the lysimeters of this type are: (a) Mechanically weight type of University of California at Davis (Fig.5) which is 20 feet in diameter and 3 feet deep. The sensitivity of the instrument was 0.0012 inches of evapotranspiration. (b) Float type (Fig.6) which operation of the system is based on Archimedes' principle. The soil container is equipped with bouyancy chambers and is floated in liquid held in an outer container. A loss or gain of weight in the lysimeter results in a change of liquid level which can be converted to equivalent depth of evapotranspiration. (c) Hydraulic weighing type (Fig.7) which the total weight of soil filled tank is distributed on water filled rubber bags. The pressure in the bag, therefore, varies directly with the weight of the tank. Changes in water pressure developed by loss or gain of the weight can be read from the manometer in the observation tank and can be converted to evapotranspiration depth.

In general, the weighing types lysimeters are more accurate than the non-weighing types. The float and hydraulic weighing lysimeters can be used for daily evapotranspiration measurements accurately while the meachanically weight type of the University of California can measure with exceptional accuracy for a period of as short as 4 minutes.

5. Calculations of Reference Crop Evapotranspiration

Evapotranspiration data are essential for planning, design, and operation of irrigation systems. Direct measurements are time consuming, expensive and usually not available where they are needed. Since the values of crop evapotranspiration depend on numerous factors as indicated previously, in practice, they are estimated base on climatic data and crop coefficient according to the relation:

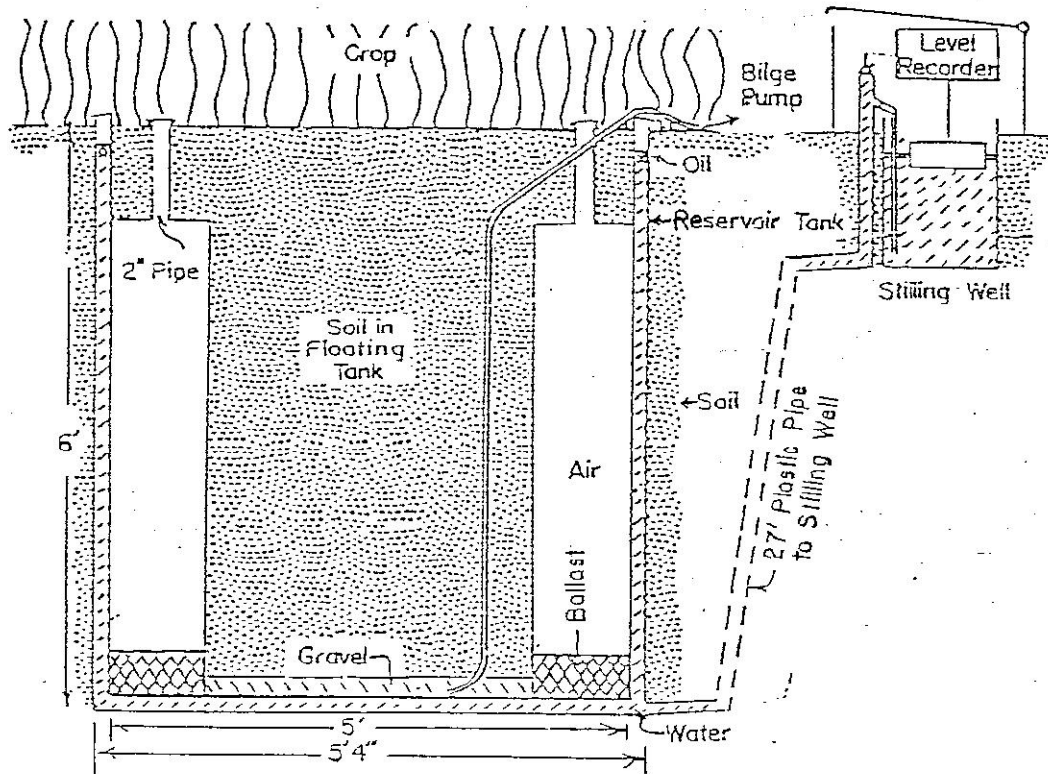

Fig. 6 Floating lysimeter and recorder installation (King et. al. 1956)

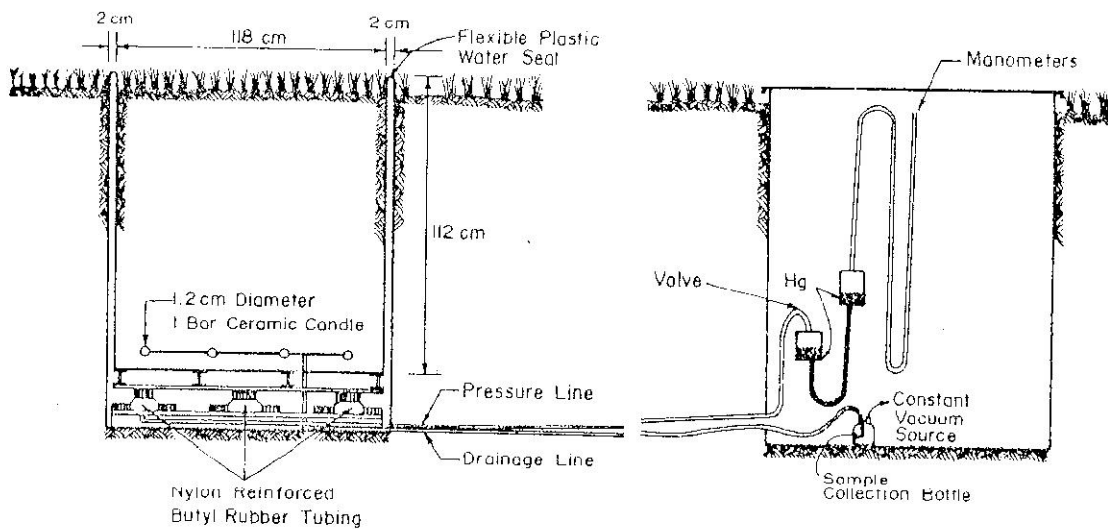

Fig. 7 Hydraulic Weighing Lysimeter

$$ET_c = K_c \cdot ET_o \dots\dots\dots (3)$$

where ET_c = crop evapotranspiration,
 K_c = crop coefficient which varies with the crops and their growth stages,
 ET_o = potential evapotranspiration or reference crop evapotranspiration.

The term potential evapotranspiration was defined by Penman (1956) as "The amount of water transpired in unit time by a short green crop, completely shading the ground, of uniform height and never short of water". The short green crops commonly selected for ET_o measurements are grasses. However, other crops such as alfalfa and rhine were also used by many investigators. To avoid confusion, name of the crop used in potential evapotranspiration measurements or development of estimating formula has to be specified. This requirement gives a new term: "reference crop evapotranspiration".

The concept of potential evapotranspiration is quite useful because when the soil moisture is not limited, the other influencing soil factors become negligible. Selection of grasses as reference crop would also eliminate crop factors affecting evapotranspiration rates because short green grasses have uniform population density and the aerodynamic will be practically the same for all growth stages. Evapotranspiration rate of short green grasses, growing in soil with sufficient soil moisture, therefore, depends only on the climate conditions of the field. Numerous formulae for estimating potential evapotranspiration have been developed based on this concept. Thus, where climatic data are available, it is possible to estimate the potential evapotranspiration rates for that area by using any of these formulae.

The crop coefficient, K_c , is a crop and its growth stage dependent. It is derived experimentally from a ratio of the crop evapotranspiration to reference crop evapotranspiration measured under the same soil, climatic and cultural conditions of the same time period. Precautions has to be taken in using crop coefficients presented in

the potential evapotranspiration formula being used.

There are many methods available for estimating potential evapotranspiration from climatic data. Jensen (1973) classified these formulae into five categories: temperature, radiation, combination, humidity and miscellaneous. Each of the five consists of many formulae. Selection depends on the data available: climatic and topographic conditions of the area and personal preference. Typical formulae commonly used are Blaney-Criddle, Radiation, Penman and pan evaporation methods, which are discussed next.

5.1 Blaney-Criddle Formula Blaney-Criddle formula was initially developed and intended for estimating seasonal consumptive use of crops. The formula is given by:

$$U = K \cdot \frac{\sum t \cdot p}{100} \dots\dots\dots (4)$$

where U = consumptive use of the crop during the growing season in inches,
 K = crop coefficient,
 t = mean monthly air temperature in °F,
 p = monthly percentage of daytime hours of the year.

Although the Blaney-Criddle formula was one of the most widely use among its class, it has become less and less favour by most scientists and engineers. The weakness of the method, like other temperature based formulae, can be summarized as follows:

- (1) The temperature is not a good indicator of the energy available for evapotranspiration. Most studies confirm that solar radiation is the most important factor influencing evapotranspiration rate.
- (2) In region with cold winter, the air temperature in spring lags behind radiation. Use of the formula for ET_c estimation in spring in those areas would underestimate the actual rate.
- (3) The formula does not take into consideration the effect of wind speed and advection. In some region,

advection of warm air increase temperature while the solar radiation and evapotranspiration are not increased.

In order to improve the performance of Blaney-Criddle formula, Doorenbos and Pruitt (1984) proposed an adjustment factor which depends on relative humidity, sunshine hours and wind speed during the daytime. The formula for estimating reference crop evapotranspiration in metric unit is given by:

$$ET_0 = c [p (0.46T + 8)] \text{ mm/day} \dots\dots\dots (5)$$

where ET_0 = reference crop evapotranspiration in mm/day for the month considered,

T = mean daily air temperature of the month - °C,

p = mean daily percentage of annual daytime hours obtained from Table 1,

c = adjustment factors.

After the term $p (0.46T + 8) = f$ has been calculated, ET_0 can be read directly from the graph of Fig. 8. It should be noted that the formula has been modified to estimate reference crop evapotranspiration. After determining ET_0 , evapotranspiration of the interested crop can be predicted by using appropriate crop coefficient (K_c) or $ET_c = K_c ET_0$. The crop coefficients (K) employed by Blaney-Criddle are not applicable in the modified formula because they are heavily dependent on climatic factors which were not taken into account in the original formula.

The calculation procedure of the modified Blaney-Criddle method will be illustrated by using climatic data of Khon Kaen, a northeastern province of Thailand. A summary of all climatological data which were collected by the Meteorological Department, Ministry of Communications, are presented in Table 2.

Example 1

Location: Khon Kaen, Thailand; Latitude 16°N; Altitude
165 m (MSL)

Month : April

Table 1 Mean Daily Percentage (p) of Annual Daytime Hours for Different Latitudes
(Doorenbos and Pruitt, 1984)

| Latitude | North ^{1/} | | Jan | | Feb | | Mar | | Apr | | May | | June | | July | | Aug | | Sept | | Oct | | Nov | | Dec | | |
|----------|---------------------|----|------|-----|------|------|-----|-----|-----|-----|-----|-----|------|------|------|-----|------|-----|------|-----|-----|-----|-----|-----|-----|------|--|
| | South | 1/ | July | Aug | Sept | Oct | Nov | Dec | Jan | Feb | Mar | Apr | May | June | July | Aug | Sept | Oct | Nov | Dec | Jan | Feb | Mar | Apr | May | June | |
| 60° | | | .15 | .20 | .26 | .32 | .38 | .41 | .40 | .34 | .28 | .22 | .17 | .13 | | | | | | | | | | | | | |
| 58 | | | .16 | .21 | .26 | .32 | .37 | .40 | .39 | .34 | .28 | .23 | .18 | .15 | | | | | | | | | | | | | |
| 56 | | | .17 | .21 | .26 | .32 | .36 | .39 | .38 | .33 | .28 | .23 | .18 | .16 | | | | | | | | | | | | | |
| 54 | | | .18 | .22 | .26 | .31 | .36 | .38 | .37 | .33 | .28 | .23 | .19 | .17 | | | | | | | | | | | | | |
| 52 | | | .19 | .22 | .27 | .31 | .35 | .37 | .36 | .33 | .28 | .24 | .20 | .17 | | | | | | | | | | | | | |
| 50 | | | .19 | .23 | .27 | .31 | .34 | .36 | .35 | .32 | .28 | .24 | .20 | .18 | | | | | | | | | | | | | |
| 48 | | | .20 | .23 | .27 | .31 | .34 | .36 | .35 | .32 | .28 | .24 | .21 | .19 | | | | | | | | | | | | | |
| 46 | | | .20 | .23 | .27 | .30 | .34 | .35 | .34 | .32 | .28 | .24 | .21 | .20 | | | | | | | | | | | | | |
| 44 | | | .21 | .24 | .27 | .30 | .33 | .35 | .34 | .31 | .28 | .25 | .22 | .20 | | | | | | | | | | | | | |
| 42 | | | .21 | .24 | .27 | .30 | .33 | .34 | .33 | .31 | .28 | .25 | .22 | .21 | | | | | | | | | | | | | |
| 40 | | | .22 | .24 | .27 | .30 | .32 | .34 | .33 | .31 | .28 | .25 | .22 | .21 | | | | | | | | | | | | | |
| 35 | | | .23 | .25 | .27 | .29 | .31 | .32 | .32 | .30 | .28 | .25 | .23 | .22 | | | | | | | | | | | | | |
| 30 | | | .24 | .25 | .27 | .29 | .31 | .32 | .31 | .30 | .28 | .26 | .24 | .23 | | | | | | | | | | | | | |
| 25 | | | .24 | .26 | .27 | .29 | .30 | .31 | .31 | .29 | .28 | .26 | .25 | .24 | | | | | | | | | | | | | |
| 20 | | | .25 | .26 | .27 | .28* | .29 | .30 | .30 | .29 | .28 | .26 | .25 | .25 | | | | | | | | | | | | | |
| 15 | | | .26 | .26 | .27 | .28* | .29 | .29 | .29 | .28 | .28 | .27 | .26 | .25 | | | | | | | | | | | | | |
| 10 | | | .26 | .27 | .27 | .28 | .28 | .28 | .28 | .28 | .28 | .27 | .26 | .26 | | | | | | | | | | | | | |
| 5 | | | .27 | .27 | .27 | .28 | .28 | .28 | .28 | .28 | .28 | .27 | .26 | .26 | | | | | | | | | | | | | |
| 0 | | | .27 | .27 | .27 | .27 | .27 | .27 | .27 | .27 | .27 | .27 | .27 | .27 | | | | | | | | | | | | | |

^{1/} Southern latitudes : apply 6 month difference from Northern latitudes as shown.

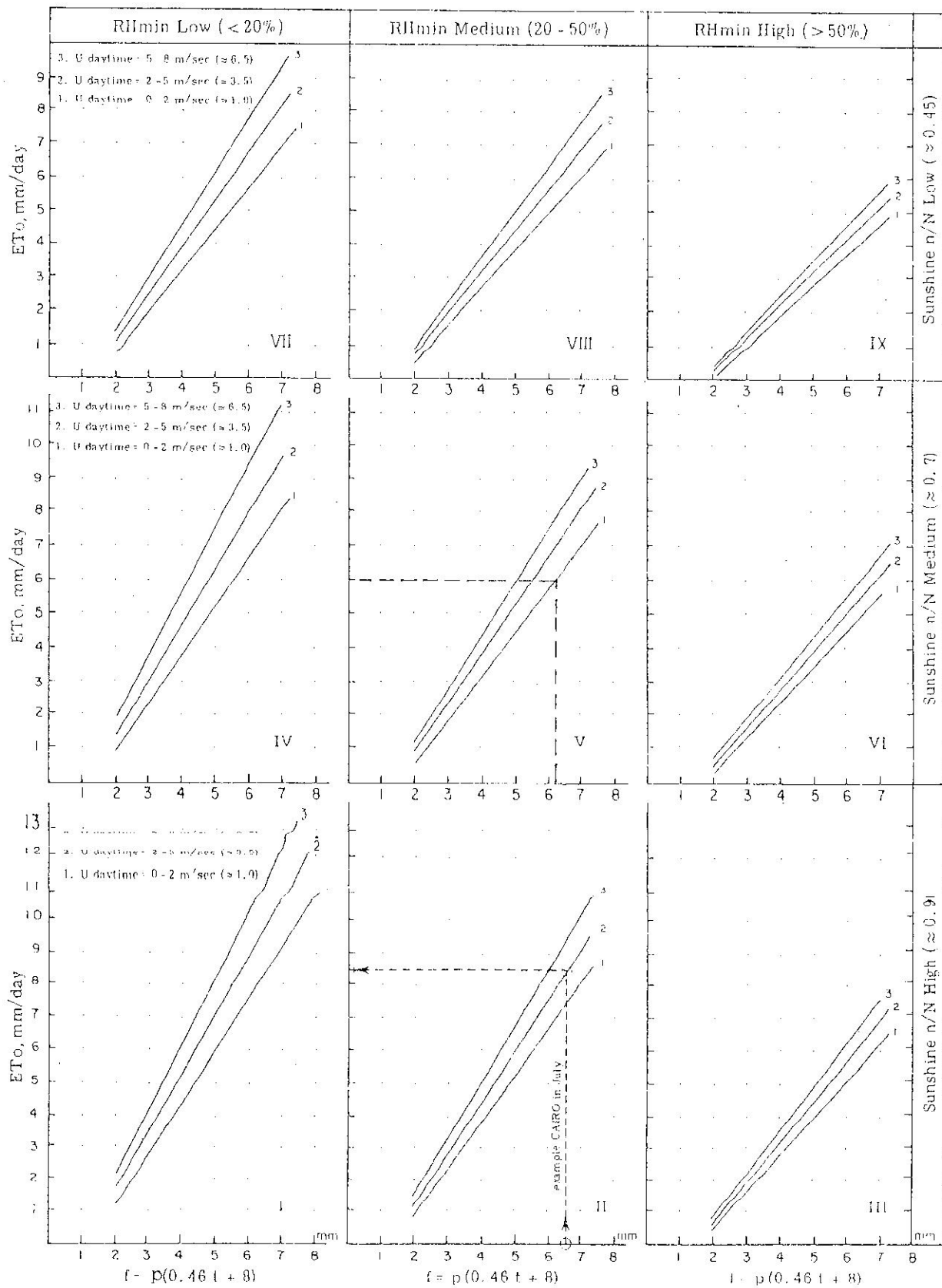

Fig.8 Prediction of ETo from Blaney-Criddle f factor for different conditions of minimum relative humidity, sunshine duration and day time wind.

Basic Monthly Data: From Table 2,

$$\begin{aligned} T_{\max} &= 36.5 \text{ }^{\circ}\text{C} \\ T_{\min} &= 24.2 \text{ }^{\circ}\text{C} \\ T_{\text{mean}} &= 30.2 \text{ }^{\circ}\text{C} \\ RH_{\min} &= 43.3 \% \\ n &= 255.9/30 = 8.53 \text{ hrs.} \end{aligned}$$

U_2 daytime (by estimation) is 1.36 m/sec (Low)

Tabulated Data:

$$\begin{aligned} p &= 0.28 \% \quad (\text{Table 1}) \\ N &= 12.5 \text{ hrs.} \quad (\text{Table 4}) \end{aligned}$$

Calculation:

$$\begin{aligned} p (0.46T + 8) &= 0.28 (0.46 \times 30.2 + 8) \\ &= 6.13 \text{ mm/day} \\ n/N &= \frac{8.53}{12.5} = 0.68 \end{aligned}$$

From Fig.8 using line 1 of block V,

$$ET_{\circ} = \underline{6.0 \text{ mm/day}}$$

5.2 Radiation Method There are many formulae which can be classified as radiation method. The widely used and cited in literatures are those developed by Makkink (1957), Turc (1961) and Jensen-Haise (1963). All of these can be condensed into a general form:

$$ET_{\circ} = \varnothing_1 R_s + \varnothing_2 \dots\dots\dots (6)$$

where ET_{\circ} is reference crop evapotranspiration, R_s is the solar radiation, usually expressed in terms of equivalent evaporation and \varnothing_1 and \varnothing_2 are empirical functions of temperature, relative humidity, and elevation.

Doorenbos and Pruitt (1984) proposed the relationships which adopted from Makkink formula as:

$$ET_{\circ} = c (W. R_s) \text{ mm/day} \dots\dots\dots (7)$$

where ET_{\circ} = reference crop evapotranspiration in mm/day,
 R_s = solar radiation in equivalent evaporation in mm/day,

Table 2 Climatological data for the period 1951-1980 of Khon Kaen

Station KHON Kaen Elevation of Station above MSL 165 meters
 Index Station 48 381 Height of barometer above MSL. 166 meters
 Latitude 16° 26' N. Height of thermometer above ground 1.25 meters
 Longitude 102° 50' E. Height of wind vane above ground 10.55 meters
 Height of rain gauge 1.00 meters

| | Jan | Feb | Mar | Apr | May | Jun | Jul | Aug | Sep | Oct | Nov | Dec | Year |
|-----------------------------|-------|----------|-------|-------|-------|-------|-------|-------|----------|-------|-------|-------|---------------|
| Pressure (+1000 or 900 mbs) | | | | | | | | | | | | | |
| Mean | 14.01 | 11.79 | 09.70 | 08.00 | 06.38 | 05.18 | 05.15 | 05.16 | 07.08 | 10.70 | 13.18 | 14.48 | 09.23 |
| Ext. Max. | 26.70 | 24.72 | 24.74 | 21.68 | 14.90 | 13.70 | 12.62 | 13.92 | 15.46 | 19.70 | 23.42 | 25.08 | 26.70 |
| Ext. Min. | 02.51 | 00.90 | 99.98 | 98.61 | 97.40 | 94.92 | 95.05 | 95.58 | 94.32 | 07.90 | 03.30 | 03.44 | 94.32 |
| Mean daily range | 5.60 | 6.01 | 6.01 | 5.73 | 5.13 | 4.26 | 4.06 | 4.14 | 4.55 | 4.75 | 4.82 | 5.11 | 5.02 |
| Temperature (°C) | | | | | | | | | | | | | |
| Mean | 23.2 | 25.7 | 28.8 | 30.2 | 29.4 | 28.7 | 28.1 | 27.7 | 27.2 | 26.7 | 25.0 | 23.2 | 27.0 |
| Mean Max. | 30.5 | 32.7 | 35.4 | 36.5 | 34.8 | 35.2 | 32.6 | 32.0 | 31.5 | 31.4 | 30.8 | 30.0 | 32.6 |
| Mean Min. | 16.0 | 18.8 | 22.1 | 24.2 | 24.7 | 24.6 | 24.2 | 24.1 | 23.6 | 22.3 | 19.2 | 16.3 | 21.7 |
| Ext. Max. | 37.2 | 41.0 | 41.8 | 42.8 | 41.2 | 39.4 | 38.0 | 37.0 | 35.5 | 35.8 | 37.2 | 35.8 | 42.8 |
| Ext. Min. | 5.7 | 10.4 | 10.3 | 14.0 | 19.8 | 20.7 | 20.2 | 20.8 | 19.3 | 14.0 | 9.4 | 5.6 | 5.6 |
| Relative Humidity (%) | | | | | | | | | | | | | |
| Mean | 63.0 | 62.0 | 60.0 | 63.0 | 72.0 | 76.0 | 77.0 | 80.0 | 82.0 | 76.0 | 70.0 | 66.0 | 70.0 |
| Mean Max. | 85.8 | 83.2 | 81.2 | 82.3 | 87.7 | 88.9 | 90.0 | 91.4 | 93.0 | 90.7 | 87.8 | 87.1 | 87.4 |
| Mean Min. | 43.5 | 41.5 | 39.9 | 43.3 | 53.8 | 60.0 | 61.7 | 64.6 | 65.4 | 59.2 | 49.7 | 44.8 | 52.4 |
| Ext. Min. | 11.0 | 10.0 | 10.0 | 14.0 | 27.0 | 33.0 | 34.0 | 37.0 | 45.0 | 26.0 | 21.0 | 15.0 | 10.0 |
| Dew Point (°C) | | | | | | | | | | | | | |
| Mean | 15.3 | 17.1 | 19.4 | 21.6 | 23.4 | 23.7 | 23.6 | 23.7 | 24.4 | 21.9 | 18.7 | 15.9 | 20.7 |
| Evaporation (mm.) | | | | | | | | | | | | | |
| Mean Pan | 161.6 | 168.1 | 215.6 | 225.0 | 203.5 | 168.5 | 171.2 | 151.9 | 138.0 | 160.7 | 159.2 | 160.6 | 2083.9 |
| Cloudiness (0-8) | | | | | | | | | | | | | |
| Mean | 2.6 | 2.8 | 3.1 | 4.1 | 5.6 | 6.4 | 6.5 | 6.7 | 6.3 | 4.6 | 3.5 | 2.9 | 6.2 |
| Sunshine Duration (hr.) | | | | | | | | | | | | | |
| Mean | 275.3 | 242.8 | 243.1 | 255.9 | 297.2 | 196.9 | 183.5 | 162.3 | 163.6 | 243.5 | 255.6 | 206.1 | 2755.8 |
| Visibility (km.) | | | | | | | | | | | | | |
| 700 L.S.T. | 4.9 | 4.6 | 4.5 | 6.1 | 7.5 | 7.8 | 7.9 | 7.6 | 7.2 | 7.8 | 6.6 | 5.8 | 6.5 |
| Mean | 7.0 | 5.4 | 6.0 | 7.3 | 8.4 | 8.6 | 8.6 | 8.4 | 8.2 | 8.5 | 8.3 | 7.6 | 7.8 |
| Wind (Knots) | | | | | | | | | | | | | |
| Prevailing wind | NE | NE | NE | SW | SW | SW | SW | SW | SW | NE | NE | NE | - |
| Mean wind speed | 3.2 | 3.0 | 3.5 | 3.7 | 3.6 | 3.9 | 4.1 | 3.8 | 2.8 | 3.4 | 3.8 | 3.6 | - |
| Max. wind speed | 33 NE | 33 N, SW | 40 NE | 46 W | 47 SW | 59 SW | 55 W | 40 E | 33 N, NE | 34 NE | 35 N | 38 NE | 59 SW, WSW, W |
| Rainfall (mm.) | | | | | | | | | | | | | |
| Mean | 7.7 | 15.4 | 34.2 | 62.7 | 171.8 | 180.8 | 156.5 | 188.3 | 276.9 | 86.0 | 13.5 | 2.9 | 1196.7 |
| Mean rainy days | 1.1 | 2.5 | 4.3 | 6.8 | 13.7 | 14.7 | 16.1 | 17.7 | 18.2 | 9.2 | 1.6 | 0.6 | 106.5 |
| Greatest in 24 hr. | 31.6 | 63.4 | 70.2 | 65.7 | 96.9 | 123.8 | 92.8 | 134.8 | 141.6 | 124.5 | 81.0 | 26.6 | 141.6 |
| Day/Year | 31/53 | 3/66 | 11/52 | 6/65 | 9/52 | 12/70 | 26/63 | 12/78 | 7/51 | 26/69 | 10/74 | 20/71 | 7/51 |
| Number of Days with | | | | | | | | | | | | | |
| Haze | 23.8 | 24.5 | 25.1 | 15.4 | 1.6 | 0.0 | 0.1 | 0.3 | 0.7 | 3.8 | 9.6 | 20.7 | 125.6 |
| Fog | 4.3 | 2.7 | 3.2 | 1.2 | 0.3 | 0.1 | 0.1 | 0.2 | 2.3 | 1.3 | 5.1 | 4.9 | 25.7 |
| Hail | 0.0 | 0.0 | 0.0 | 0.0 | 0.0 | 0.0 | 0.0 | 0.0 | 0.0 | 0.0 | 0.0 | 0.0 | 0.0 |
| Thunderstorm | 0.3 | 1.4 | 5.9 | 11.8 | 17.4 | 14.2 | 13.4 | 11.5 | 13.3 | 5.9 | 0.4 | 0.1 | 96.6 |
| Squall | 0.0 | 0.0 | 0.0 | 0.0 | 0.0 | 0.0 | 0.0 | 0.0 | 0.1 | 0.0 | 0.0 | 0.0 | 0.1 |

Remark : 1. Evaporation 1961-1980
 2. Sunshine Duration 1957-1980

- W = weighing factor which depends on temperature and altitude,
- c = adjustment factor which depends on mean humidity and daytime wind conditions.

Where measured values of R_s for the area of interest are not available, they can be estimated from measured sunshine duration records and the extraterrestrial radiation, R_a , by the equation:

$$R_s = (0.25 + 0.50 n/N) R_a \dots\dots\dots (8)$$

Where n/N is the ratio between actual measured bright sunshine hours and maximum possible sunshine hours of the same period, R_a is the extraterrestrial radiation or the amount of radiation received at top of the atmosphere in equivalent evaporation in mm/day.

The values of R_a and N which are both latitude and time of the year dependent are given in Table 3 and 4, Also, the values of weighing factor W which depends on mean air temperature and altitude are given in Table 5.

If the measured values of a bright sunshine hours are not available, the ratio n/N can be estimated from cloudiness observations. For climatic conditions of Thailand, the relation between the ratio of bright sunshine and cloudiness is given by

$$n/N = 0.745 + 0.095 C_c - 0.02 C_c^2 \dots\dots\dots (9)$$

Where C_c is cloudiness expressed in oktas (0 to 8) scale. the n/N ratio for various values of C_c are given in Table 6.

After the value of $W.R_s$ has been determined, appropriate adjustment for humidity and wind speed can be done by using Fig. 9.

Example 2

Location: Khon Kaen, Thailand; Latitude $16^{\circ}N$; Altitude
165 m. (MSL.)
Month: April
Basic Monthly Data: From Table 2,

Table 3 Extra Terrestrial Radiation (R_a) expressed in equivalent evaporation in mm/day.

| Northern Hemisphere | | | | | | | | | | | | | Southern Hemisphere | | | | | | | | | | | | |
|---------------------|------|------|------|------|------|------|------|------|------|------|------|------|---------------------|------|------|------|------|------|------|------|------|------|------|--|--|
| Jan | Feb | Mar | Apr | May | June | July | Aug | Sept | Oct | Nov | Dec | Jan | Feb | Mar | Apr | May | June | July | Aug | Sept | Oct | Nov | Dec | | |
| 3.8 | 6.1 | 9.4 | 12.7 | 15.8 | 17.1 | 16.4 | 14.1 | 10.9 | 7.4 | 4.5 | 3.2 | 17.5 | 14.7 | 10.9 | 7.0 | 4.2 | 3.1 | 3.5 | 5.5 | 8.9 | 12.9 | 16.5 | 18.2 | | |
| 4.3 | 6.6 | 9.8 | 13.0 | 15.9 | 17.2 | 16.5 | 14.3 | 11.2 | 7.8 | 5.0 | 3.7 | 17.6 | 14.9 | 11.2 | 7.5 | 4.7 | 3.5 | 4.0 | 6.0 | 9.3 | 13.2 | 16.6 | 18.2 | | |
| 4.9 | 7.1 | 10.2 | 13.3 | 16.0 | 17.2 | 16.6 | 14.5 | 11.5 | 8.3 | 5.5 | 4.3 | 17.7 | 15.1 | 11.5 | 7.9 | 5.2 | 4.0 | 4.4 | 6.5 | 9.7 | 13.4 | 16.7 | 18.3 | | |
| 5.3 | 7.6 | 10.6 | 13.7 | 16.1 | 17.2 | 16.6 | 14.7 | 11.9 | 8.7 | 6.0 | 4.7 | 17.8 | 15.3 | 11.9 | 8.4 | 5.7 | 4.4 | 4.9 | 6.9 | 10.2 | 13.7 | 16.7 | 18.3 | | |
| 5.9 | 8.1 | 11.0 | 14.0 | 16.2 | 17.3 | 16.7 | 15.0 | 12.2 | 9.1 | 6.5 | 5.2 | 17.8 | 15.5 | 12.2 | 8.8 | 6.1 | 4.9 | 5.4 | 7.4 | 10.6 | 14.0 | 16.8 | 18.3 | | |
| 6.4 | 8.6 | 11.4 | 14.3 | 16.4 | 17.3 | 16.7 | 15.2 | 12.5 | 9.6 | 7.0 | 5.7 | 17.9 | 15.7 | 12.5 | 9.2 | 6.6 | 5.3 | 5.9 | 7.9 | 11.0 | 14.2 | 16.9 | 18.3 | | |
| 6.9 | 9.0 | 11.8 | 14.5 | 16.4 | 17.2 | 16.7 | 15.3 | 12.8 | 10.0 | 7.5 | 6.1 | 17.9 | 15.8 | 12.8 | 9.6 | 7.1 | 5.8 | 6.3 | 8.3 | 11.4 | 14.4 | 17.0 | 18.3 | | |
| 7.4 | 9.4 | 12.1 | 14.7 | 16.4 | 17.2 | 16.7 | 15.4 | 13.1 | 10.6 | 8.0 | 6.6 | 17.9 | 16.0 | 13.2 | 10.1 | 7.5 | 6.3 | 6.8 | 8.8 | 11.7 | 14.6 | 17.0 | 18.2 | | |
| 7.9 | 9.8 | 12.4 | 14.8 | 16.5 | 17.1 | 16.8 | 15.5 | 13.4 | 10.8 | 8.5 | 7.2 | 17.8 | 16.1 | 13.5 | 10.5 | 8.0 | 6.8 | 7.2 | 9.2 | 12.0 | 14.9 | 17.1 | 18.2 | | |
| 8.3 | 10.2 | 12.8 | 15.0 | 16.5 | 17.0 | 16.8 | 15.6 | 13.6 | 11.2 | 9.0 | 7.8 | 17.8 | 16.2 | 13.8 | 10.9 | 8.5 | 7.3 | 7.7 | 9.6 | 12.4 | 15.1 | 17.2 | 18.1 | | |
| 8.8 | 10.7 | 13.1 | 15.2 | 16.5 | 17.0 | 16.8 | 15.7 | 13.9 | 11.6 | 9.5 | 8.3 | 17.8 | 16.4 | 14.0 | 11.3 | 8.9 | 7.8 | 8.1 | 10.1 | 12.7 | 15.3 | 17.3 | 18.1 | | |
| 9.3 | 11.1 | 13.4 | 15.3 | 16.5 | 16.8 | 16.7 | 15.7 | 14.1 | 12.0 | 9.9 | 8.8 | 17.7 | 16.4 | 14.3 | 11.6 | 9.3 | 8.2 | 8.6 | 10.4 | 13.0 | 15.4 | 17.2 | 17.9 | | |
| 9.8 | 11.5 | 13.7 | 15.3 | 16.4 | 16.7 | 16.6 | 15.7 | 14.3 | 12.3 | 10.3 | 9.3 | 17.6 | 16.4 | 14.4 | 12.0 | 9.7 | 8.7 | 9.1 | 10.9 | 13.2 | 15.5 | 17.2 | 17.8 | | |
| 10.2 | 11.9 | 13.9 | 15.4 | 16.4 | 16.6 | 16.5 | 15.8 | 14.5 | 12.6 | 10.7 | 9.7 | 17.5 | 16.5 | 14.6 | 12.3 | 10.2 | 9.1 | 9.5 | 11.2 | 13.4 | 15.6 | 17.1 | 17.7 | | |
| 10.7 | 12.3 | 14.2 | 15.5 | 16.3 | 16.4 | 16.4 | 15.8 | 14.6 | 13.0 | 11.1 | 10.2 | 17.4 | 16.5 | 14.8 | 12.6 | 10.6 | 9.6 | 10.0 | 11.6 | 13.7 | 15.7 | 17.0 | 17.5 | | |
| 11.2 | 12.7 | 14.4 | 15.6 | 16.3 | 16.4 | 16.3 | 15.9 | 14.8 | 13.3 | 11.6 | 10.7 | 17.3 | 16.5 | 15.0 | 13.0 | 11.0 | 10.0 | 10.4 | 12.0 | 13.9 | 15.8 | 17.0 | 17.4 | | |
| 11.6 | 13.0 | 14.6 | 15.6 | 16.1 | 16.1 | 16.1 | 15.8 | 14.9 | 13.6 | 12.0 | 11.1 | 17.1 | 16.5 | 15.1 | 13.2 | 11.4 | 10.4 | 10.8 | 12.3 | 14.1 | 15.8 | 16.8 | 17.1 | | |
| 12.0 | 13.3 | 14.7 | 15.6 | 16.0 | 15.9 | 15.9 | 15.7 | 15.0 | 13.9 | 12.4 | 11.6 | 16.9 | 16.4 | 15.2 | 13.5 | 11.7 | 10.8 | 11.2 | 12.6 | 14.3 | 15.8 | 16.7 | 16.8 | | |
| 12.4 | 13.6 | 14.9 | 15.7 | 15.8 | 15.7 | 15.7 | 15.7 | 15.1 | 14.1 | 12.8 | 12.0 | 16.7 | 16.4 | 15.3 | 13.7 | 12.1 | 11.2 | 11.6 | 12.9 | 14.5 | 15.8 | 16.5 | 16.6 | | |
| 12.8 | 13.9 | 15.1 | 15.7 | 15.7 | 15.5 | 15.5 | 15.6 | 15.2 | 14.4 | 13.3 | 12.5 | 16.6 | 16.3 | 15.4 | 14.0 | 12.5 | 11.6 | 12.0 | 13.2 | 14.7 | 15.8 | 16.4 | 16.5 | | |
| 13.2 | 14.2 | 15.3 | 15.7 | 15.5 | 15.3 | 15.3 | 15.5 | 15.3 | 14.7 | 13.6 | 12.9 | 16.4 | 16.3 | 15.5 | 14.2 | 12.8 | 12.0 | 12.4 | 13.5 | 14.8 | 15.9 | 16.2 | 16.2 | | |
| 13.6 | 14.5 | 15.3 | 15.6 | 15.3 | 15.0 | 15.1 | 15.4 | 15.3 | 14.8 | 13.9 | 13.3 | 16.1 | 16.1 | 15.5 | 14.4 | 13.1 | 12.4 | 12.7 | 13.7 | 14.9 | 15.8 | 16.0 | 16.0 | | |
| 13.9 | 14.8 | 15.4 | 15.4 | 15.1 | 14.7 | 14.9 | 15.2 | 15.3 | 15.0 | 14.2 | 13.7 | 15.8 | 16.0 | 15.6 | 14.7 | 13.4 | 12.8 | 13.1 | 14.0 | 15.0 | 15.7 | 15.8 | 15.7 | | |
| 14.3 | 15.0 | 15.5 | 15.5 | 14.9 | 14.4 | 14.6 | 15.1 | 15.3 | 15.1 | 14.5 | 14.1 | 15.5 | 15.8 | 15.6 | 14.9 | 13.8 | 13.2 | 13.4 | 14.3 | 15.1 | 15.6 | 15.5 | 15.4 | | |
| 14.7 | 15.3 | 15.6 | 15.3 | 14.6 | 14.2 | 14.3 | 14.9 | 15.3 | 15.3 | 14.8 | 14.4 | 15.3 | 15.7 | 15.5 | 14.1 | 14.1 | 13.5 | 13.7 | 14.5 | 15.2 | 15.5 | 15.3 | 15.1 | | |
| 15.0 | 15.5 | 15.7 | 15.3 | 14.4 | 13.9 | 14.1 | 14.8 | 15.3 | 15.4 | 15.1 | 14.8 | 15.0 | 15.5 | 15.7 | 15.3 | 14.4 | 13.9 | 14.1 | 14.8 | 15.3 | 15.4 | 15.1 | 14.8 | | |

Table 4 Mean Daily Duration of Maximum Possible Sunshine (Hours (N)) for Different Months and Latitudes

| Northern Lats Southern Lats | Jan | Feb | Mar | Apr | May | June | July | Aug | Sept | Oct | Nov | Dec | Jan | Feb | Mar | Apr | May | June | July | Aug | Sept | Oct | Nov | Dec |
|--------------------------------------|------|------|------|--------|------|------|------|------|------|------|------|------|------|------|------|--------|------|------|------|------|------|------|------|------|
| | July | Aug | Sept | Oct | Nov | Dec | Jan | Feb | Mar | Apr | May | June | July | Aug | Sept | Oct | Nov | Dec | Jan | Feb | Mar | Apr | May | June |
| 50 | 8.5 | 10.1 | 11.8 | 13.8 | 15.4 | 16.3 | 15.9 | 14.5 | 12.7 | 10.8 | 9.1 | 8.1 | 8.5 | 10.1 | 11.8 | 13.8 | 15.4 | 16.3 | 15.9 | 14.5 | 12.7 | 10.8 | 9.1 | 8.1 |
| 48 | 8.8 | 10.2 | 11.8 | 13.6 | 15.2 | 16.0 | 15.6 | 14.3 | 12.6 | 10.9 | 9.3 | 8.3 | 8.8 | 10.2 | 11.8 | 13.6 | 15.2 | 16.0 | 15.6 | 14.3 | 12.6 | 10.9 | 9.3 | 8.3 |
| 46 | 9.1 | 10.4 | 11.9 | 13.5 | 14.9 | 15.7 | 15.4 | 14.2 | 12.6 | 10.9 | 9.5 | 8.7 | 9.1 | 10.4 | 11.9 | 13.5 | 14.9 | 15.7 | 15.4 | 14.2 | 12.6 | 10.9 | 9.5 | 8.7 |
| 44 | 9.3 | 10.5 | 11.9 | 13.4 | 14.7 | 15.4 | 15.2 | 14.0 | 12.6 | 11.0 | 9.7 | 8.9 | 9.3 | 10.5 | 11.9 | 13.4 | 14.7 | 15.4 | 15.2 | 14.0 | 12.6 | 11.0 | 9.7 | 8.9 |
| 42 | 9.4 | 10.6 | 11.9 | 13.4 | 14.6 | 15.2 | 14.9 | 13.9 | 12.6 | 11.1 | 9.8 | 9.1 | 9.4 | 10.6 | 11.9 | 13.4 | 14.6 | 15.2 | 14.9 | 13.9 | 12.6 | 11.1 | 9.8 | 9.1 |
| 40 | 9.6 | 10.7 | 11.9 | 13.3 | 14.4 | 15.0 | 14.7 | 13.7 | 12.5 | 11.2 | 10.0 | 9.3 | 9.6 | 10.7 | 11.9 | 13.3 | 14.4 | 15.0 | 14.7 | 13.7 | 12.5 | 11.2 | 10.0 | 9.3 |
| 35 | 10.1 | 11.0 | 11.9 | 13.1 | 14.0 | 14.5 | 14.3 | 13.5 | 12.4 | 11.3 | 10.3 | 9.8 | 10.1 | 11.0 | 11.9 | 13.1 | 14.0 | 14.5 | 14.3 | 13.5 | 12.4 | 11.3 | 10.3 | 9.8 |
| 30 | 10.4 | 11.1 | 12.0 | 12.9 | 13.6 | 14.0 | 13.9 | 13.2 | 12.4 | 11.5 | 10.6 | 10.2 | 10.4 | 11.1 | 12.0 | 12.9 | 13.6 | 14.0 | 13.9 | 13.2 | 12.4 | 11.5 | 10.6 | 10.2 |
| 25 | 10.7 | 11.3 | 12.0 | 12.7 | 13.3 | 13.7 | 13.5 | 13.0 | 12.3 | 11.6 | 10.9 | 10.6 | 10.7 | 11.3 | 12.0 | 12.7 | 13.3 | 13.7 | 13.5 | 13.0 | 12.3 | 11.6 | 10.9 | 10.6 |
| 20 | 11.0 | 11.5 | 12.0 | 12.6* | 13.1 | 13.3 | 13.2 | 12.8 | 12.3 | 11.7 | 11.2 | 10.9 | 11.0 | 11.5 | 12.0 | 12.6* | 13.1 | 13.3 | 13.2 | 12.8 | 12.3 | 11.7 | 11.2 | 10.9 |
| 15 | 11.3 | 11.6 | 12.0 | 12.5** | 12.8 | 13.0 | 12.9 | 12.6 | 12.2 | 11.8 | 11.4 | 11.2 | 11.3 | 11.6 | 12.0 | 12.5** | 12.8 | 13.0 | 12.9 | 12.6 | 12.2 | 11.8 | 11.4 | 11.2 |
| 10 | 11.6 | 11.8 | 12.0 | 12.3 | 12.6 | 12.7 | 12.6 | 12.4 | 12.1 | 11.8 | 11.6 | 11.5 | 11.6 | 11.8 | 12.0 | 12.3 | 12.6 | 12.7 | 12.6 | 12.4 | 12.1 | 11.8 | 11.6 | 11.5 |
| 5 | 11.8 | 11.9 | 12.0 | 12.2 | 12.3 | 12.4 | 12.3 | 12.3 | 12.1 | 12.0 | 11.9 | 11.8 | 11.8 | 11.9 | 12.0 | 12.2 | 12.3 | 12.4 | 12.3 | 12.3 | 12.1 | 12.0 | 11.9 | 11.8 |
| 0 | 12.1 | 12.1 | 12.1 | 12.1 | 12.1 | 12.1 | 12.1 | 12.1 | 12.1 | 12.1 | 12.1 | 12.1 | 12.1 | 12.1 | 12.1 | 12.1 | 12.1 | 12.1 | 12.1 | 12.1 | 12.1 | 12.1 | 12.1 | 12.1 |

Table 5 Values of Weighting Factor (W) for the Effect of Radiation on ETo at Different Temperatures and Altitudes

| Temperature °C | 2 | 4 | 6 | 8 | 10 | 12 | 14 | 16 | 18 | 20 | 22 | 24 | 26 | 28 | 30 | 32 | 34 | 36 | 38 | 40 | | | | |
|-----------------|------|-----|-----|-----|-----|-----|-----|-----|-----|-----|-----|-----|-----|-----|-----|-----|-----|-----|-----|-----|--|--|--|--|
| W at altitude m | | | | | | | | | | | | | | | | | | | | | | | | |
| 0 | 0.43 | .46 | .49 | .52 | .55 | .58 | .61 | .64 | .66 | .68 | .71 | .73 | .75 | .77 | .78 | .80 | .82 | .83 | .84 | .85 | | | | |
| 500 | .45 | .48 | .51 | .54 | .57 | .60 | .62 | .65 | .67 | .70 | .72 | .74 | .76 | .78 | .79 | .81 | .82 | .84 | .85 | .86 | | | | |
| 1 000 | .46 | .49 | .52 | .55 | .58 | .61 | .64 | .66 | .69 | .71 | .73 | .75 | .77 | .79 | .80 | .82 | .83 | .85 | .86 | .87 | | | | |
| 2 000 | .49 | .52 | .55 | .58 | .61 | .64 | .66 | .69 | .71 | .73 | .75 | .77 | .79 | .81 | .82 | .84 | .85 | .86 | .87 | .88 | | | | |
| 3 000 | .52 | .55 | .58 | .61 | .64 | .66 | .69 | .71 | .73 | .75 | .77 | .79 | .81 | .82 | .84 | .85 | .86 | .88 | .89 | | | | | |
| 4 000 | .55 | .58 | .61 | .64 | .66 | .69 | .71 | .73 | .76 | .78 | .79 | .81 | .83 | .84 | .85 | .86 | .88 | .89 | .90 | | | | | |

Table 6 Values of n/N ratio as a function of cloudness
(0-8) (Applicable for Thailand).

| Cloudiness (0 - 8) | $n/N = 0.745 + 0.095 C_c - 0.02 C_c^2$ | | | | |
|-----------------------|--|-------|-------|-------|-------|
| | 0 | 0.2 | 0.4 | 0.6 | 0.8 |
| 0 | 0.745 | 0.763 | 0.780 | 0.795 | 0.808 |
| 1 | 0.820 | 0.830 | 0.839 | 0.846 | 0.851 |
| 2 | 0.855 | 0.857 | 0.859 | 0.857 | 0.854 |
| 3 | 0.850 | 0.844 | 0.837 | 0.828 | 0.817 |
| 4 | 0.805 | 0.791 | 0.776 | 0.759 | 0.40 |
| 5 | 0.720 | 0.698 | 0.675 | 0.650 | 0.623 |
| 6 | 0.595 | 0.565 | 0.534 | 0.501 | 0.466 |
| 7 | 0.430 | 0.392 | 0.353 | 0.312 | 0.269 |
| 8 | 0.225 | - | - | - | - |

$T_{\text{mean}} = 30.2 \text{ } ^\circ\text{C}$
 $RH_{\text{mean}} = 63 \%$
 Sunshine (n) = 8.53 hrs/day
 Daytime wind (by estimation) 1.36 m/sec (Low)

Calculation:

R_a from Table 3 = 15.6 mm/day
 N from Table 4 = 12.5 hrs.
 $n/N = 8.53/12.5 = 0.68$
 $R_s = (0.25 + 0.50 n/N) R_a = 9.20 \text{ mm/day}$
 W from Table 5 = 0.78
 $W \cdot R_s = 7.18 \text{ mm/day}$

From Fig.9 for RH_{mean} of 63%, U_2 daytime of 1.36 m/sec, using line 1 block 3

$$ET_o = \underline{6 \text{ mm/day}}$$

5.3 Penman Method Basically, the Penman equation (Penman, 1945) consists of two important components in evapotranspiration process: energy component and aerodynamic component. The first component is related to the energy available for evaporation while the second is related to transport mechanism available to remove the water vapor from the soil and crop surfaces. Penman formula, in short form, is given by:

$$ET_o = W \cdot R_n + (1 - W) E_a \dots\dots\dots (10)$$

where ET_o = potential evapotranspiration in mm/day,
 W = temperature and altitude related weighing factor which values can be obtained from Table 5,
 R_n = net radiation in equivalent evaporation in mm/day,
 E_a = aerodynamic component in mm/day.

The net radiation can be measured directly using net radiometer. However, this value is usually not available and has to be estimated by using equation:

$$R_n = (1 - \alpha) R_s - R_b \dots\dots\dots (11)$$

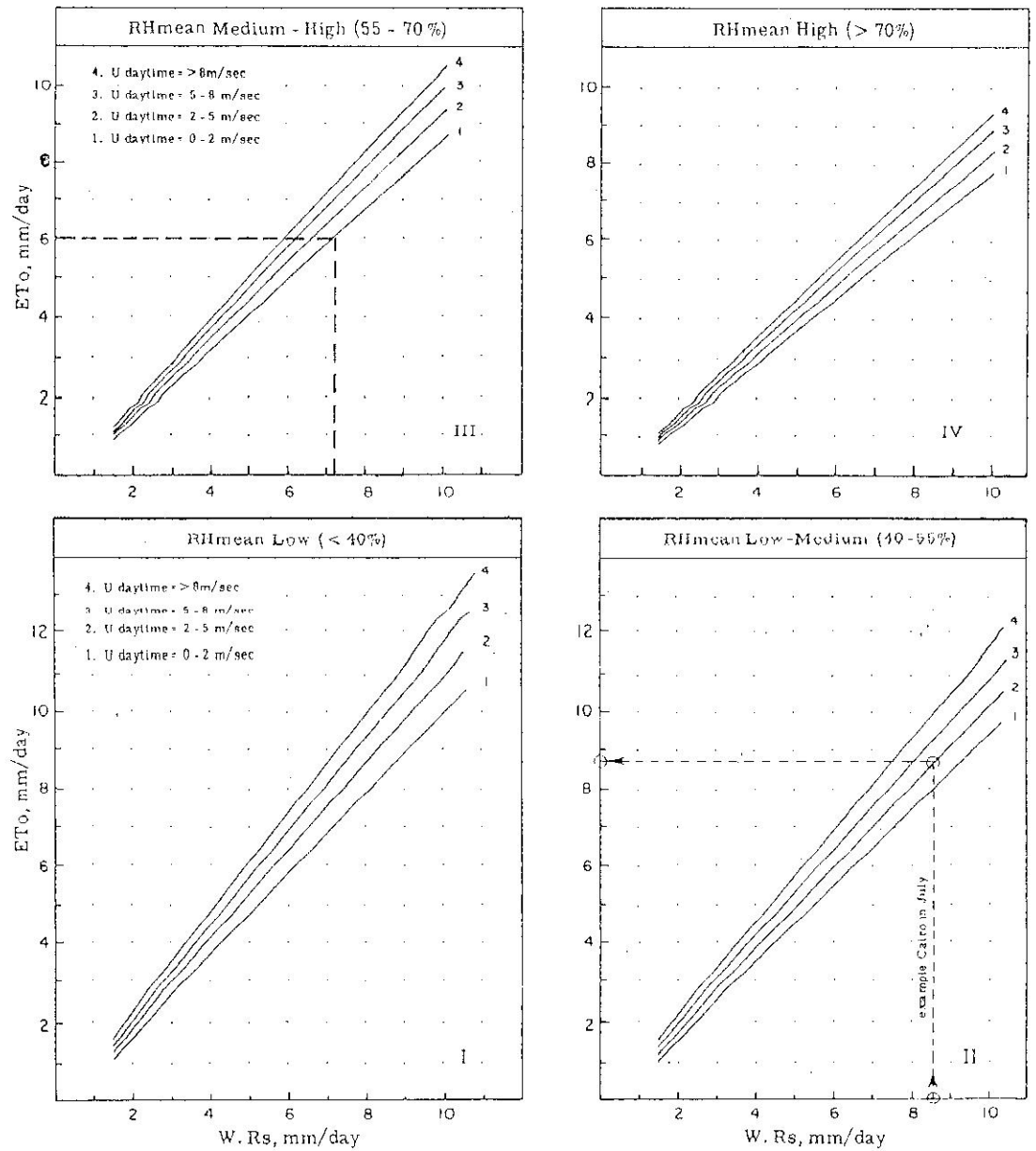

Fig. 9 Prediction of ET_0 from $W.R_s$ for different conditions of mean relative humidity and day time wind (Doorenbos and Pruitt, 1984)

Where α is the short wave reflection coefficient and R_b is the net outgoing thermal radiation. The reflection coefficients of most green crops with full cover vary from 0.20 to 0.25 and a value of 0.23 is commonly used. The net outgoing longwave radiation, R_b can be estimated from:

$$R_b = \sigma T_K^4 (0.34 - 0.044 \sqrt{e_d}) (0.10 + 0.90 n/N) \dots (12)$$

Where σT_K^4 represents the black body radiation which depends on temperature and can be obtained from Table 7, e_d is the actual vapor pressure of the air and n/N is the ratio between actual and possible hours of sunshine during the same period.

The aerodynamic component of the Penman equation is given by:

$$E_a = 0.265 (1.0 + 0.0062 U_2) (e_a - e_d) \dots (13)$$

Where U_2 is the average wind velocity at 2 meters high in km/day. The wind velocity, sometimes, is made at some other height which needs to be converted to two meters level before substituting into the aerodynamic term. The conversion can be done by using power law:

$$U_2 = U_z \left(\frac{2}{z}\right)^{0.2} \dots (14)$$

Where U_z is the wind speed measured at a height z meters from the ground in km/day.

The saturation deficiency ($e_a - e_d$) represents the capacity of the air to absorb more water vapor at mean air temperature. The first term, e_a , is the saturation vapor pressure at mean air temperature. The first term, e_a , is the saturation vapor pressure at mean air temperature which values can be obtained from Table 8. The actual vapor pressure, e_d , is more difficult to determine than e_a and must be estimated using either one of these relations:

- a) $e_d =$ saturation vapor pressure at dew point temperature, or
- b) $e_d = e_a \times \frac{\text{relative humidity}}{100}$

Table 7 Values of black body radiation σT_K^4 in equivalent evaporation in mm/day.

| T °C | σT_K^4 mm/day | T °C | σT_K^4 mm/day | T °C | σT_K^4 mm/day |
|------|--------------------------|------|--------------------------|------|--------------------------|
| 0 | 11.21 | 17 | 14.28 | 34 | 17.93 |
| 1 | 11.38 | 18 | 14.48 | 35 | 18.17 |
| 2 | 11.55 | 19 | 14.68 | 36 | 18.41 |
| 3 | 11.72 | 20 | 14.88 | 37 | 18.64 |
| 4 | 11.89 | 21 | 15.08 | 38 | 18.89 |
| 5 | 12.06 | 22 | 15.29 | 39 | 19.13 |
| 6 | 12.23 | 23 | 15.50 | 40 | 19.38 |
| 7 | 12.41 | 24 | 15.71 | 41 | 19.63 |
| 8 | 12.59 | 25 | 15.92 | 42 | 19.88 |
| 9 | 12.77 | 26 | 16.14 | 43 | 20.13 |
| 10 | 12.95 | 27 | 16.35 | 44 | 20.39 |
| 11 | 13.13 | 28 | 16.57 | 45 | 20.65 |
| 12 | 13.32 | 29 | 16.79 | 46 | 20.91 |
| 13 | 13.51 | 30 | 17.02 | 47 | 21.17 |
| 14 | 13.70 | 31 | 17.24 | 48 | 21.44 |
| 15 | 13.89 | 32 | 17.47 | 49 | 21.70 |
| 16 | 14.08 | 33 | 17.70 | 50 | 21.98 |

Table 8 Saturation vapor pressure over water in millibars

| T°C | Fraction of temperature | | | | | | | | | |
|-----|-------------------------|--------|--------|--------|--------|--------|--------|--------|--------|--------|
| | .0 | .1 | .2 | .3 | .4 | .5 | .6 | .7 | .8 | .9 |
| 25 | 31.67 | 31.86 | 32.05 | 32.24 | 32.43 | 32.63 | 32.82 | 33.02 | 33.21 | 33.41 |
| 26 | 33.61 | 33.81 | 34.01 | 34.21 | 34.41 | 34.61 | 34.82 | 35.02 | 35.23 | 35.44 |
| 27 | 35.65 | 35.86 | 36.07 | 36.28 | 36.49 | 36.71 | 36.92 | 37.14 | 37.36 | 37.58 |
| 28 | 37.80 | 38.02 | 38.24 | 38.46 | 38.69 | 38.91 | 39.14 | 39.36 | 39.58 | 39.82 |
| 29 | 40.05 | 40.29 | 40.52 | 40.75 | 40.99 | 41.23 | 41.47 | 41.70 | 41.94 | 42.19 |
| 30 | 42.43 | 42.67 | 42.92 | 43.17 | 43.41 | 43.66 | 43.91 | 44.16 | 44.42 | 44.67 |
| 31 | 44.93 | 45.18 | 45.44 | 45.70 | 45.96 | 46.22 | 46.49 | 46.75 | 47.02 | 47.28 |
| 32 | 47.55 | 47.82 | 48.09 | 48.36 | 48.64 | 48.91 | 49.19 | 49.47 | 49.74 | 50.02 |
| 33 | 50.31 | 50.59 | 50.87 | 51.16 | 51.45 | 51.74 | 52.03 | 52.32 | 52.61 | 52.90 |
| 34 | 53.20 | 53.50 | 53.80 | 54.10 | 54.40 | 54.70 | 55.00 | 55.31 | 55.62 | 55.93 |
| 35 | 56.24 | 56.55 | 56.86 | 57.18 | 57.49 | 57.81 | 58.13 | 58.45 | 58.77 | 59.10 |
| 36 | 59.42 | 59.75 | 60.08 | 60.41 | 60.74 | 61.07 | 61.41 | 61.74 | 62.08 | 62.42 |
| 37 | 62.76 | 63.10 | 63.45 | 63.80 | 64.14 | 64.49 | 64.84 | 65.20 | 65.55 | 65.91 |
| 38 | 66.26 | 66.62 | 66.98 | 67.35 | 67.71 | 68.08 | 68.45 | 68.81 | 69.19 | 69.56 |
| 39 | 69.93 | 70.31 | 70.69 | 71.07 | 71.45 | 71.83 | 72.22 | 72.60 | 72.99 | 73.38 |
| 40 | 73.78 | 74.17 | 74.57 | 74.97 | 75.36 | 75.77 | 76.17 | 76.57 | 76.98 | 77.39 |
| 41 | 77.80 | 78.21 | 78.63 | 79.05 | 79.46 | 79.88 | 80.31 | 80.73 | 81.16 | 81.58 |
| 42 | 82.01 | 82.45 | 82.88 | 83.32 | 83.75 | 84.19 | 84.64 | 85.08 | 85.52 | 85.97 |
| 43 | 86.42 | 86.87 | 87.33 | 87.78 | 88.24 | 88.70 | 89.16 | 89.63 | 90.09 | 90.56 |
| 44 | 91.03 | 91.51 | 91.98 | 92.46 | 92.94 | 93.42 | 93.90 | 94.39 | 94.87 | 95.36 |
| 45 | 95.35 | 96.35 | 96.84 | 97.34 | 97.84 | 98.35 | 98.85 | 99.36 | 99.87 | 100.38 |
| 46 | 100.89 | 101.41 | 101.93 | 102.45 | 102.97 | 103.50 | 104.03 | 104.56 | 105.09 | 105.62 |
| 47 | 106.16 | 106.70 | 107.24 | 107.78 | 108.33 | 108.88 | 109.43 | 109.98 | 110.54 | 111.10 |
| 48 | 111.66 | 112.22 | 112.79 | 113.35 | 113.93 | 114.50 | 115.07 | 115.65 | 116.23 | 116.81 |
| 49 | 117.40 | 117.99 | 118.58 | 119.17 | 119.77 | 120.37 | 120.97 | 121.57 | 122.18 | 122.79 |
| 50 | 123.40 | 124.01 | 124.63 | 125.25 | 125.87 | 126.49 | 127.12 | 127.75 | 128.38 | 129.01 |

Table 8 Saturation vapor pressure over water in millibars

| T °C | Fraction of temperature | | | | | | | | | |
|------|-------------------------|-------|-------|-------|-------|-------|-------|-------|-------|-------|
| | .0 | .1 | .2 | .3 | .4 | .5 | .6 | .7 | .8 | .9 |
| 0 | 6.11 | 6.15 | 6.20 | 6.24 | 6.29 | 6.33 | 6.38 | 6.42 | 6.47 | 6.52 |
| 1 | 6.57 | 6.61 | 6.66 | 6.71 | 6.76 | 6.81 | 6.85 | 6.90 | 6.95 | 7.00 |
| 2 | 7.05 | 7.10 | 7.16 | 7.21 | 7.25 | 7.31 | 7.36 | 7.41 | 7.47 | 7.52 |
| 3 | 7.57 | 7.63 | 7.68 | 7.74 | 7.79 | 7.85 | 7.90 | 7.96 | 8.01 | 8.07 |
| 4 | 8.13 | 8.19 | 8.24 | 8.30 | 8.36 | 8.42 | 8.48 | 8.54 | 8.60 | 8.66 |
| 5 | 8.72 | 8.78 | 8.84 | 8.90 | 8.96 | 9.03 | 9.09 | 9.15 | 9.22 | 9.28 |
| 6 | 9.35 | 9.41 | 9.48 | 9.54 | 9.61 | 9.67 | 9.74 | 9.81 | 9.88 | 9.94 |
| 7 | 10.01 | 10.08 | 10.15 | 10.22 | 10.29 | 10.36 | 10.43 | 10.50 | 10.58 | 10.65 |
| 8 | 10.72 | 10.79 | 10.87 | 10.94 | 11.02 | 11.09 | 11.17 | 11.24 | 11.32 | 11.40 |
| 9 | 11.47 | 11.55 | 11.63 | 11.71 | 11.79 | 11.87 | 11.95 | 12.03 | 12.11 | 12.19 |
| 10 | 12.27 | 12.35 | 12.44 | 12.52 | 12.61 | 12.69 | 12.77 | 12.86 | 12.95 | 13.03 |
| 11 | 13.12 | 13.21 | 13.29 | 13.38 | 13.47 | 13.56 | 13.65 | 13.74 | 13.83 | 13.92 |
| 12 | 14.02 | 14.11 | 14.20 | 14.30 | 14.39 | 14.49 | 14.58 | 14.68 | 14.77 | 14.87 |
| 13 | 14.97 | 15.07 | 15.17 | 15.27 | 15.36 | 15.47 | 15.57 | 15.67 | 15.77 | 15.87 |
| 14 | 15.98 | 16.08 | 16.19 | 16.29 | 16.40 | 16.50 | 16.61 | 16.72 | 16.83 | 16.93 |
| 15 | 17.04 | 17.15 | 17.26 | 17.38 | 17.49 | 17.60 | 17.71 | 17.83 | 17.94 | 18.06 |
| 16 | 18.17 | 18.29 | 18.41 | 18.52 | 18.64 | 18.76 | 18.88 | 19.00 | 19.12 | 19.24 |
| 17 | 19.37 | 19.49 | 19.61 | 19.74 | 19.86 | 19.99 | 20.12 | 20.24 | 20.37 | 20.50 |
| 18 | 20.63 | 20.76 | 20.89 | 21.02 | 21.15 | 21.29 | 21.42 | 21.56 | 21.69 | 21.83 |
| 19 | 21.96 | 22.10 | 22.24 | 22.38 | 22.52 | 22.66 | 22.80 | 22.94 | 23.08 | 23.23 |
| 20 | 23.37 | 23.52 | 23.66 | 23.81 | 23.96 | 24.11 | 24.26 | 24.41 | 24.55 | 24.71 |
| 21 | 24.86 | 25.01 | 25.17 | 25.32 | 25.48 | 25.63 | 25.79 | 25.95 | 26.11 | 26.27 |
| 22 | 26.43 | 26.59 | 26.75 | 26.92 | 27.08 | 27.25 | 27.41 | 27.58 | 27.75 | 27.92 |
| 23 | 28.09 | 28.26 | 28.43 | 28.60 | 28.77 | 28.95 | 29.12 | 29.30 | 29.47 | 29.65 |
| 24 | 29.83 | 30.01 | 30.19 | 30.37 | 30.55 | 30.74 | 30.92 | 31.11 | 31.29 | 31.48 |

Illustration for calculating potential evapotranspiration by Penman method is presented in Example 3.

5.4 Pan Evaporation Method Since the terms of energy available and transport mechanism in evaporation process, is somewhat similar to that of transpiration, pan evaporation has been used for estimating crop evapotranspiration and irrigation scheduling with high degree of success. In addition to climatic conditions, the rate of evaporation from a pan varies with the size, colour, material, depth of water, types of pan, and installation of the pan. A dark colour pan will loss more water than the white one. Turbulent of air flow over the pan developed by large depth of water level below the rim or installation of the pan itself increases the evaporation rate. Pans which are designed to install in the ground (sunken pans) have less exposure to direct sun light and therefore rates of evaporation will be less than pans installed on the ground.

Since evaporation rates from pan are highly dependent on the design and installation, to avoid the discrepancy in the design and measurements the World Meteorological Organization adopted the U.S. Weather Bureau Class A pan as a standard for climatological observations. The Class A pan is of cylindrical design 10 inches deep and 47.5 inches inside diameter. It is constructed of galvanized steel. Details of the dimensions and installations are presented in Fig. 10.

Class A pan should be located at the middle of the field of fairly level, sodded and free of obstructions. Trees, buildings, and shrubs should be no closer to the pan than two times and preferably four times their height above the pan. The grass should be frequently watered and removed to keep it below the level of the pan. The pan should be free of any obstructions that cast shadows over it during any part of the day other than brief periods near sunrise or sunset. The pan should be filled with clean, grease free water to a

Example 3

Computational Sheet for Penman Method

Location Khon Kaen Latitude 16° Crop Grass

Formula : $ET_o = W.R_n + (1 - W) E_a$; $R_n = (1 - \alpha) R_s - R_b$;

$$E_a = 0.265 (1.0 + 0.0062 U_2)(e_a - e_d)$$

| | |
|---|-------------|
| A. Data: | April |
| 1. Air temperature - °C (Table 2) | 30.2 |
| 2. Relative humidity - fraction (Table 2) | 0.63 |
| 3. Sunshine hour, n - hr/day (Table 2) | 8.53 |
| 4. Wind speed, U_2 - km/day at 2 m. (Estimated by from (Table 2)) | 118 |
| 5. Radiation rate R_a - mm/day (Table 3) | 15.6 |
| 6. Max. possible sunshine N - hr (Table 4) | 12.5 |
| 7. Reflection coefficients α - fraction | 0.23 |
| B. Solving expression: $(1 - \alpha) R_s$ | |
| 8. $(1 - \alpha)$ | 0.77 |
| 9. $R_s = (0.25 + 0.50 n/N) R_a$, mm/day | 9.20 |
| 10. $(1 - \alpha) R_s = \text{item 8} \times \text{item 9}$, mm/day | <u>7.09</u> |
| C. Solving expression: $R_b = \sigma TK^4 (0.34 - 0.044 \sqrt{e_d})(0.10 + 0.90 n/N)$ | |
| 11. Vapour pressure | |
| (a) Saturated, e_a (Table 8) | 42.92 |
| (b) Actual, $e_d = (RH \times e_a)$ | 27.04 |
| 12. σTK^4 (Table 7) | 17.06 |
| 13. $(0.34 - 0.044 \sqrt{e_d})$ | 0.11 |
| 14. $(0.10 + 0.90 n/N)$ | 0.71 |
| 15. $R_b = \text{item 12} \times \text{item 13} \times \text{item 14}$, mm/day | <u>1.33</u> |
| D. Solving for $R_n = \text{item 10} - \text{item 15}$, mm/day | <u>5.76</u> |
| E. Solving for $E_a = 0.265 (1.0 + 0.0062 U_2)(e_a - e_d)$ | |
| 16. $0.265 (e_a - e_d)$ | 4.21 |
| 17. $(1.0 + 0.0062 U_2)$ | 1.73 |
| 18. $E_a = \text{item 16} \times \text{item 17}$, mm/day | <u>7.28</u> |
| F. Solving for $ET_o = W.R_n + (1 - W) E_a$ | |
| 19. W (Table 5) | 0.78 |
| 20. $W.R_n$ | 4.49 |
| 21. $(1 - W) E_a$ | 1.60 |
| $ET_o = \text{item 20} + \text{item 21}$ (mm/day) | <u>6.09</u> |

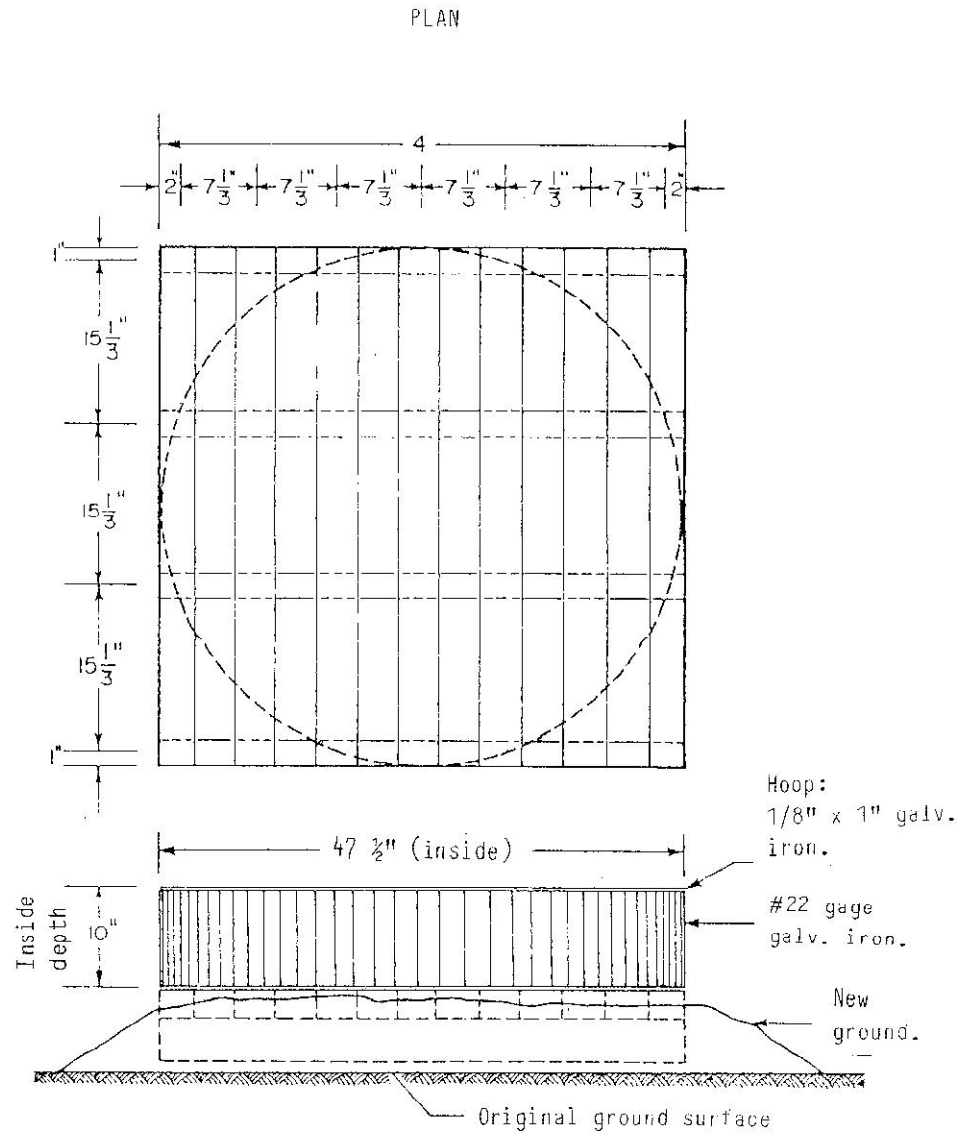

Fig. 10 Standard Weather Bureau evaporation pan.
(Class-A pan)

level of 50 mm below the rim, and refilled when the water has evaporated 25 mm. Water in the pan is regularly changed to eliminate extreme turbidity. The pan, if made of galvanized steel, should be repainted annually with aluminum paint.

The use of Class-A pan evaporation for estimating crops evapotranspiration can be divided into two categories: (1) estimation of crops evapotranspiration, and (2) estimating reference crop or potential evapotranspiration for further converting to crop evapotranspiration by multiplying with crop coefficients. Equations expressing these estimates are given by:

$$ET_c = C_p \cdot E_{pan} \dots\dots\dots (15)$$

and $ET_o = K_p \cdot E_{pan} \dots\dots\dots (16)$

where ET_c = crop evapotranspiration,

C_p = crop coefficient based on pan evaporation,

E_{pan} = pan evaporation,

ET_o = reference crop evapotranspiration,

K_p = pan coefficient, depending on the reference crop and pan involved.

The crop coefficients (C_p) for converting Class-A pan evaporation to evapotranspiration are presented in Table 9. The pan coefficients (K_p) for converting Class-A pan evaporation to grass evapotranspiration (ET_o) which were developed by Doorenbos and Pruitt (1977) are presented in Table 10.

In selecting the appropriate value of K_p in Table 10, it is necessary to consider the surrounding ground cover of the pan. Two different cases presented in the table are: (1) pan located within cropped areas surrounded by or downwind from dry surface areas (Case A) and (2) pan located within a dry or fallow area but surrounded by or downwind from irrigated or rainfed areas (Case B). The surrounding ground cover for both cases are illustrated in Fig. 11.

Table 9 Crop/Class A-pan evaporation ratio (adopted from Withers and Vipond, 1974)

| | Percentage of crop-growing season | | | | | | | | | | |
|---------------------------|--|------|------|------|------|------|------|------|------|------|------|
| | 0% | 10% | 20% | 30% | 40% | 50% | 60% | 70% | 80% | 90% | 100% |
| Alfalfa | 0.55 | 0.60 | 0.70 | 0.80 | 0.90 | 0.95 | 0.95 | 0.95 | 0.90 | 0.80 | 0.65 |
| Beans | 0.20 | 0.30 | 0.40 | 0.65 | 0.85 | 0.90 | 0.90 | 0.80 | 0.60 | 0.35 | 0.20 |
| Citrus and avocados | 0.50 | 0.45 | 0.45 | 0.45 | 0.45 | 0.45 | 0.50 | 0.55 | 0.60 | 0.55 | 0.50 |
| Corn | 0.20 | 0.30 | 0.50 | 0.65 | 0.80 | 0.90 | 0.90 | 0.85 | 0.75 | 0.60 | 0.50 |
| Cotton | 0.10 | 0.20 | 0.40 | 0.55 | 0.75 | 0.90 | 0.90 | 0.85 | 0.75 | 0.55 | 0.35 |
| Fruit, deciduous | 0.20 | 0.30 | 0.50 | 0.65 | 0.70 | 0.75 | 0.70 | 0.60 | 0.50 | 0.40 | 0.20 |
| Fruit with cover | Averages about 1.00 for periods of rapid growth of cover crop | | | | | | | | | | |
| Grain sorghum | 0.20 | 0.35 | 0.55 | 0.75 | 0.85 | 0.90 | 0.85 | 0.70 | 0.60 | 0.35 | 0.15 |
| Grain, Spring | 0.15 | 0.20 | 0.25 | 0.30 | 0.40 | 0.35 | 0.75 | 0.85 | 0.90 | 0.90 | 0.30 |
| Grain, Winter | 0.15 | 0.25 | 0.35 | 0.40 | 0.50 | 0.60 | 0.70 | 0.80 | 0.90 | 0.90 | 0.30 |
| Grapes | 0.15 | 0.15 | 0.20 | 0.35 | 0.45 | 0.55 | 0.55 | 0.45 | 0.35 | 0.25 | 0.20 |
| Ladino clover | Averages about 0.95 for maximum growth | | | | | | | | | | |
| Nuts, walnuts | 0.30 | 0.35 | 0.55 | 0.70 | 0.75 | 0.75 | 0.75 | 0.65 | 0.55 | 0.30 | 0.15 |
| Nuts, pecan | 0.35 | 0.45 | 0.55 | 0.75 | 0.75 | 0.65 | 0.50 | 0.45 | 0.40 | 0.35 | 0.30 |
| Peanuts | 0.15 | 0.25 | 0.35 | 0.45 | 0.55 | 0.60 | 0.65 | 0.65 | 0.60 | 0.45 | 0.30 |
| Potatoes | 0.20 | 0.35 | 0.45 | 0.65 | 0.80 | 0.90 | 0.95 | 0.95 | 0.95 | 0.90 | 0.90 |
| Rice | 0.80 | 0.95 | 1.05 | 1.15 | 1.20 | 1.30 | 1.30 | 1.20 | 1.10 | 0.90 | 0.50 |
| Sugar beets | 0.25 | 0.45 | 0.60 | 0.70 | 0.80 | 0.85 | 0.90 | 0.90 | 0.90 | 0.90 | 0.90 |
| Sugar cane | Varies from 0.55 to 1.00 depending upon rate and stage of growth | | | | | | | | | | |
| Vegetable, deep rooted | 0.20 | 0.20 | 0.25 | 0.35 | 0.50 | 0.65 | 0.70 | 0.60 | 0.45 | 0.35 | 0.20 |
| Vegetable, shallow rooted | 0.10 | 0.20 | 0.40 | 0.50 | 0.60 | 0.60 | 0.60 | 0.55 | 0.45 | 0.35 | 0.30 |

* Coefficients, C_p , to be used in Equation 15, $ET_c = C_p \cdot E_{pan}$.

Table 10 Pan Coefficient (K_p) for Different Groundcover, Mean Relative Humidity and 24 hour Wind (Adopted from Doorenbos and Pruitt, 1984)

| Class A pan | Case A: Pan placed in short green cropped area | | | Case B: Pan placed in dry fallow area | | | | |
|----------------------|--|-------------|-----------------|---------------------------------------|--|-------------|-----------------|--------------|
| | | low < 40 | medium 40-70 | high > 70 | | low < 40 | medium 40-70 | high > 70 |
| Relative Humidity % | Windward side distance of green crop m | | | | Windward side distance of dry fallow m | | | |
| Wind km/day | | | | | | | | |
| Light < 175 | 1 | .55 | .65 | .75 | 1 | .7 | .8 | .85 |
| | 10 | .65 | .75* | .85* | 10 | .6 | .7 | .8 |
| | 100 | .7 | .8 | .85 | 100 | .55 | .65 | .75 |
| | 1 000 | .75 | .85 | .85 | 1 000 | .5 | .6 | .7 |
| Moderate 175-425 | 1 | .5 | .6 | .65 | 1 | .65 | .75 | .8 |
| | 10 | .6 | .7 | .75 | 10 | .55 | .65 | .7 |
| | 100 | .65 | .75 | .8 | 100 | .5 | .6 | .65 |
| | 1 000 | .7 | .8 | .8 | 1 000 | .45 | .55 | .6 |
| Strong 425-700 | 1 | .45 | .5 | .6 | 1 | .6 | .65 | .7 |
| | 10 | .55 | .6 | .65 | 10 | .5 | .55 | .65 |
| | 100 | .6 | .65 | .7 | 100 | .45 | .5 | .6 |
| | 1 000 | .65 | .7 | .75 | 1 000 | .4 | .45 | .55 |
| Very strong > 700 | 1 | .4 | .45 | .5 | 1 | .5 | .6 | .65 |
| | 10 | .45 | .55 | .6 | 10 | .45 | .5 | .55 |
| | 100 | .5 | .6 | .65 | 100 | .4 | .45 | .5 |
| | 1 000 | .55 | .6 | .65 | 1 000 | .35 | .4 | .45 |

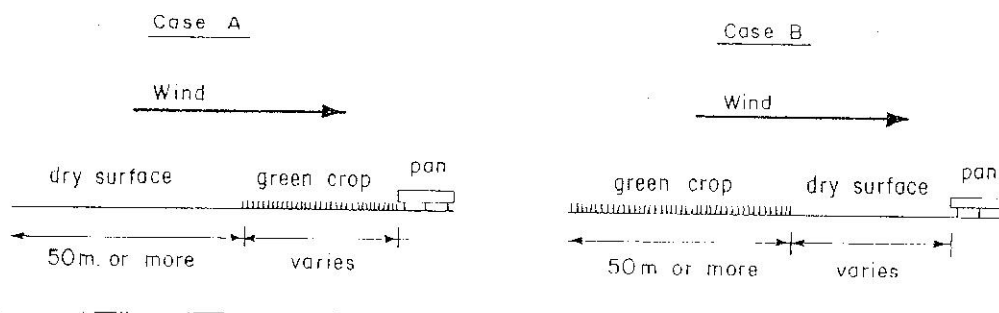

Fig. 11 Surrounding ground cover of Class-A pan for selection of pan coefficient (K_p) in Table 10

Example 4

The Class-A pan at Khon Kaen meteorological observing station is in the middle of 20 x 20 m² grass field. Other data for the month of April are as follows:

$$\begin{aligned} E_{\text{pan}} &= 225 \text{ mm/month, or } 7.5 \text{ mm/day} \\ RH_{\text{mean}} &= 63 \% \\ \text{Wind} &= 118 \text{ km/day (light)} \end{aligned}$$

Calculation:

Since the pan is in the middle of 20 x 20 m grass field, the windward side distance of green crop is 10 meters.

From Table 10 for light wind in Case A,

$$\begin{aligned} \text{for } RH \text{ between } 40 \text{ to } 70 \% \quad K_p &= 0.75 \\ RH \text{ greater than } 70 \% \quad K_p &= 0.85 \end{aligned}$$

Since RH mean of 63 % is closed to the 70 % border line, the appropriate K_p should be the average of 0.75 and 0.85 or 0.80.

Thus:

$$\begin{aligned} ET_o &= 0.80 \times 7.5 \\ &= 6.0 \text{ mm/day} \end{aligned}$$

6. Determination of Evapotranspiration

After potential evapotranspiration has been estimated from local climatic data or pan evaporation, evapotranspiration of a specific crop can be computed using the relation:

$$ET_c = K_c \cdot ET_o$$

Where ET_c is the crop evapotranspiration, K_c is the crop coefficient, and ET_o is the potential evapotranspiration.

6.1 Crop Coefficients The crop coefficient, K_c , which is the ratio of ET_c to ET_o is determined experimentally in the field. Its value depends mainly on the crop characteristics, planting data, stages of crop development, length of growing season and climatic conditions. Since the coefficient is a relative rate of water use by the crop to that of reference crop, its value is essentially

depend on the selected reference crop as well. In estimating evapotranspiration based on Equation (3), care must be taken to assure that the crop coefficient being used is based on the same reference crop as used in developing the ET_0 formula. All of the methods for estimating potential evapotranspiration discussed in this chapter, however, are based on reference crop of grass.

Doorenbos and Pruitt (1977) presented a process for obtaining crop coefficients for field and vegetables crops which can be summarized as follows:

1. Determine the planting data, total growing season and length of crop development stages of the interested crops from local information or practices in similar climatic zones. Guidelines to crop development stages are presented in Table 11.

Table 11 Stages of crop development for determining crop coefficients. (Doorenbos and Pruitt, 1984)

| | | |
|----------------------------|---|--|
| (1) initial stage | : | germination and early growth when the soil surface is not or is hardly covered by the crop (groundcover < 10 %). |
| (2) crop development stage | : | from end of initial stage to attainment of effective full groundcover (groundcover 70 - 80 %) <u>1/</u> |
| (3) mid-season stage | : | from attainment of effective full groundcover to time of start of maturing as indicated by discolouring of leaves (beans) or leaves falling off (cotton). For some crops this may extend to very near harvest (sugarbeets) unless irrigation is not applied at late season and reduction in ET crop is induced to increase yield and/or quality (sugarcane, cotton, some grains); normally well past the flowering stage of annual crops |
| (4) late season stage | : | from end of mid-season stage until full maturity or harvest. |

1/ Start of mid-season stage can be recognized in the field when crop has attained 70 to 80 % groundcover which, however, does not mean that the crop has reached its mature height, Effective full groundcover refers to cover which K_c is approaching a maximum.

2. Based on the available information or guidelines, the total length of growing season is divided into four stages; initial, crop development, mid-season and late season stages. The length of growing season with subdivisions for all growth stages is drawn on horizontal axis to indicate the planting and number of days on the time scale against the crop coefficient on vertical axis as shown in Fig. 12.
3. To obtain K_c value for initial stage, the irrigation and/or rainfall frequency as well as potential evapotranspiration during the initial stages are predicted. The K_c value is then selected from Fig. 12 and plotted in Fig. 13.
4. Based on local climate (humidity and wind) select K_c values from Table 12 for mid-season and late season stages. The mid-season K_c is plotted as a horizontal straight line covering the whole length of growth stage.
5. The K_c value for late season stage (from Table 12) is plotted at the end of late season stage. Draw a straight line between the end of the mid-season to the full maturity date.
6. During the development stage, the K_c value is assumed to follow a straight line between the end of the initial stage and the starting of the mid-season stage.

The curve may be refined by drawing a smooth curve to indicate gradual changes in the crop coefficient. An example showing crop coefficient of corn which was developed based on moderate wind speed (0-5 m/sec), RH_{min} of 60%, ET_o at initial stage of 6.0 mm/day, and irrigation frequency during the initial growth stage of 7 day is presented in Fig. 13.

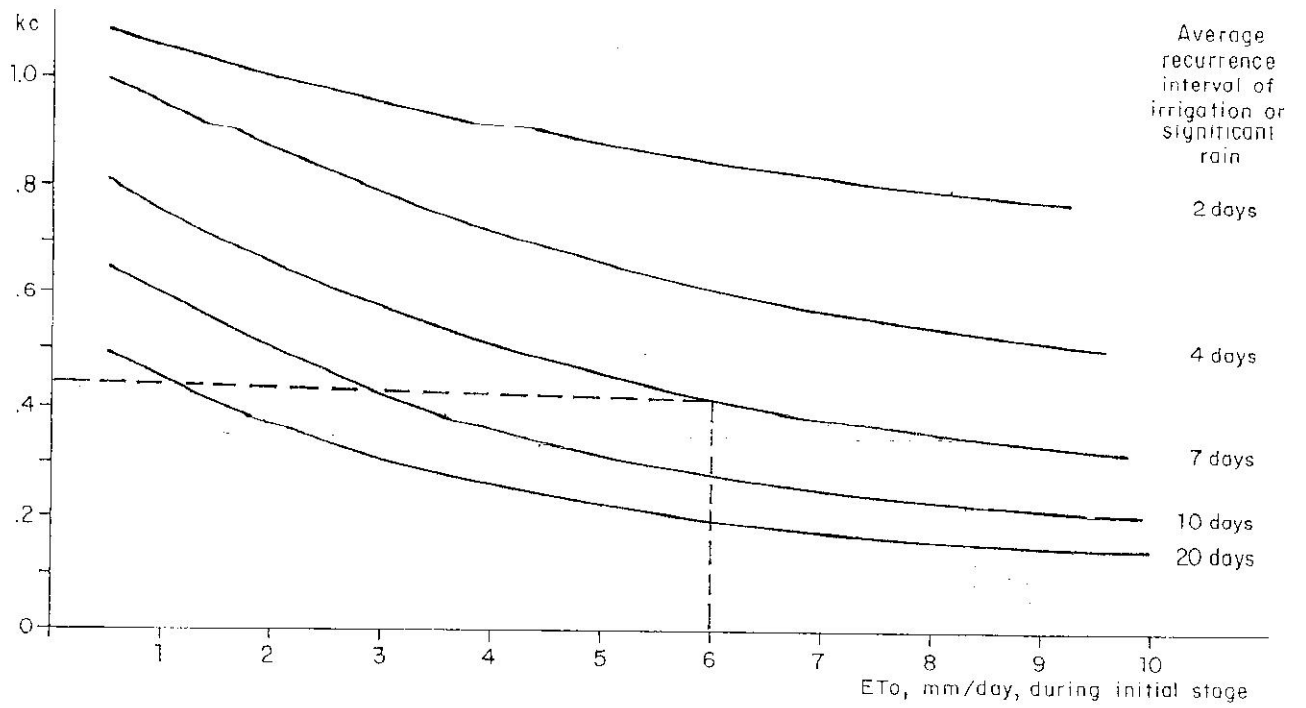

Fig. 12 Average K_c value for initial crop development stage as related to level of ET_0 and frequency of irrigation and/or significant rain (Doorenbos and Pruitt, 1984)

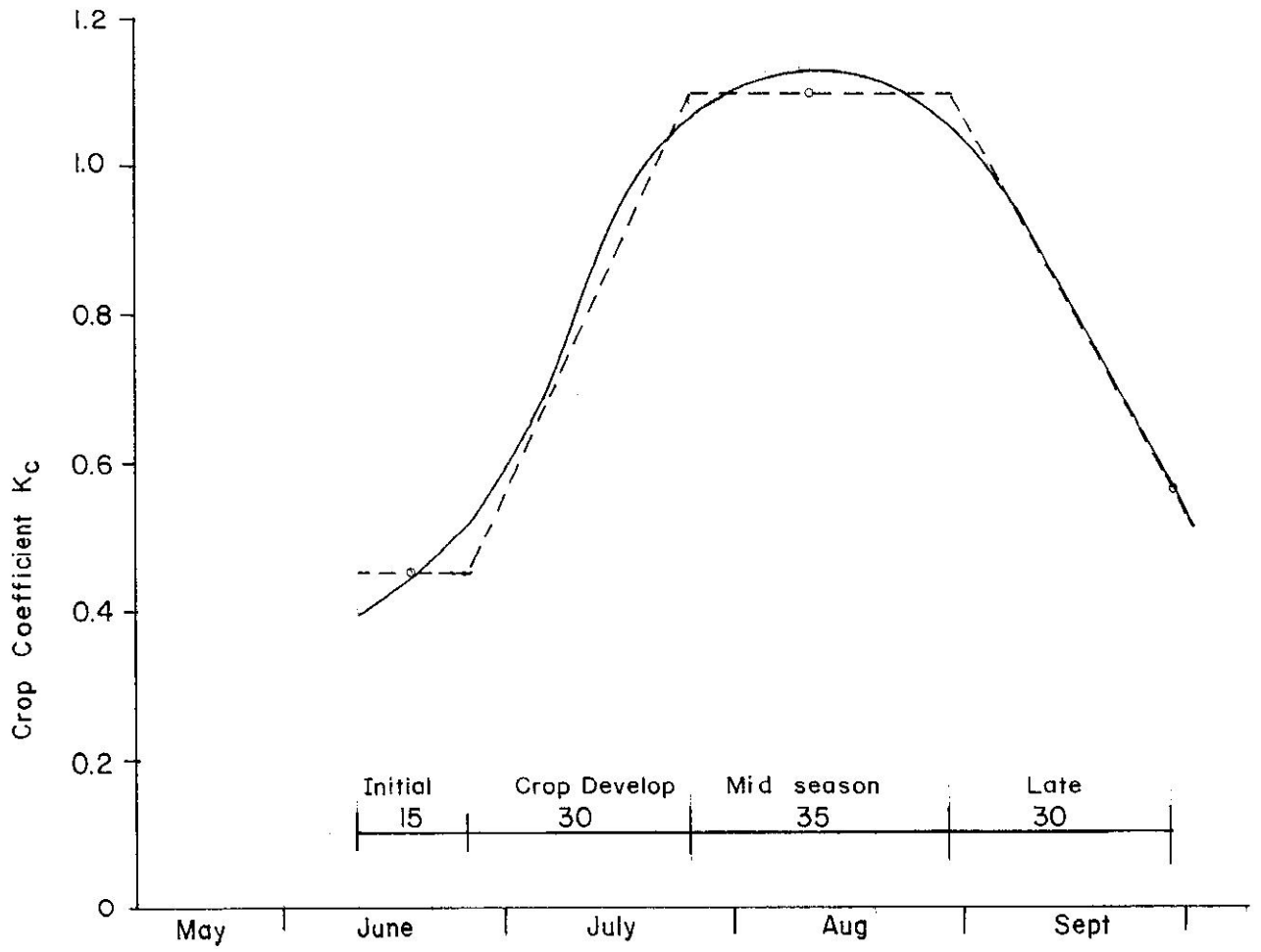

Fig. 13 Example crop coefficient of corn

Table 12 (Cont'd)

| Crop | Humidity | | | RHmin | |
|-------------------------|------------|------|--------------|-------|--------------|
| | Wind m/sec | 0-5 | >70 % 5-8 | 0-5 | <20 % 5-8 |
| Grain | 3 | 1.05 | 1.1 | 1.15 | 1.2 |
| | 4 | .3 | .3 | .25 | .25 |
| Lettuce | 3 | .95 | .95 | 1.0 | 1.05 |
| | 4 | .9 | .9 | .9 | 1.0 |
| Melons | 3 | .95 | .95 | 1.0 | 1.05 |
| | 4 | .65 | .65 | .75 | .75 |
| Onion (dry) | 3 | .95 | .95 | 1.05 | 1.1 |
| | 4 | .75 | .75 | .8 | .85 |
| (green) | 3 | .95 | .95 | 1.0 | 1.05 |
| | 4 | .95 | .95 | 1.0 | 1.05 |
| Peanuts (Groundnuts) | 3 | .95 | 1.0 | 1.05 | 1.1 |
| | 4 | .55 | .55 | .6 | .6 |
| Peas | 3 | 1.05 | 1.1 | 1.15 | 1.2 |
| | 4 | .95 | 1.0 | 1.05 | 1.1 |
| Peppers (fresh) | 3 | .95 | 1.0 | 1.05 | 1.1 |
| | 4 | .8 | .85 | .85 | .9 |
| Potato | 3 | 1.05 | 1.1 | 1.15 | 1.2 |
| | 4 | .7 | .7 | .75 | .75 |
| Sorghum | 3 | 1.0 | 1.05 | 1.1 | 1.15 |
| | 4 | .5 | .5 | .55 | .55 |
| Soybeans | 3 | 1.0 | 1.05 | 1.1 | 1.15 |
| | 4 | .45 | .45 | .45 | .45 |
| Tomato | 3 | 1.05 | 1.1 | 1.2 | 1.25 |
| | 4 | .6 | .6 | .65 | .65 |
| Wheat | 3 | 1.05 | 1.1 | 1.15 | 1.2 |
| | 4 | .25 | .25 | .2 | .2 |

6.2 Calculation of Evapotranspiration After the potential evapotranspiration and crop coefficient curve have been determined, the crop water requirement or ET_c can be evaluated by using Equation (3).

Example 5

Potential evapotranspiration of the central plain of Thailand from June to September have been estimated to be 6.00, 5.75, 5.20 and 4.85 mm/day respectively. Determine the water requirement of corn if the planting date is June 10, total length of growing season of 110 days, and the crop coefficient curve was developed and presented in Fig. 13.

Calculation:

| Month | June | July | August | September |
|-----------------------------------|------|------------------------|--------|-----------|
| (1) No. of days in the month | 20 | 31 | 31 | 28 |
| (2) K_c at the middle of period | 0.47 | 0.93 | 1.13 | 0.81 |
| (3) ET_o mm/day | 6.00 | 5.75 | 5.20 | 4.85 |
| $ET_c = K_c \cdot ET_o$ - mm/day | 2.82 | 5.35 | 5.88 | 3.93 |
| ET_c for the month - mm | 56.4 | 165.8 | 182.3 | 110.0 |
| Therefore, peak period ET_c | = | 5.88 | mm/day | |
| Seasonal water requirement | = | 56.4+165.8+182.3+110.0 | | |
| | = | 514.5 | mm. | |

7. Net Irrigation Requirements

Calculation of irrigation water requirements for planning and design of irrigation system involves determination of net irrigation requirement and requirement needed for other purposes such as land preparation, leaching of salts, crop environmental control, and losses incurred in delivering and applying water to the crops.

The net irrigation requirement is the amount of water, exclusive of rainfall or contributions from other sources, required for crop production. In other words, it is the amount of irrigation water that must be supplied to meet the consumptive-use requirement of a crop, or

$$W_n = ET_c - (R_e + G_c + S_m) \dots\dots\dots (17)$$

where W_n = net irrigation requirement of the crop,
 ET_c = crop evapotranspiration,
 R_e = effective rainfall,
 G_c = groundwater contribution,
 S_m = stored soil moisture at the beginning of growing season.

The contribution from groundwater table is determined by its depth below the root zone, the capillary properties and moisture content during the growing season of the soil. Because of the complexity in estimation and its variation with places and time, the value is usually omitted in the water requirement calculation.

Although the soil moisture storage at the beginning of growing season may be substantial in relative to the amount of water applied at each irrigation, it is usually a small percentage of seasonal water requirements and is often omitted especially area where irrigation water is plentiful.

8. Effective Rainfall

Effective rainfall is a portion of total rainfall that contributes to meet the crop water requirement and other requirements at the farm for crop productions. Rainfall on cultivated land is not all effective because part of it may be lost by surface runoff, deep percolation, or evaporation. The portion which stored in the root zone or benefited to the crops depends on many factors. Rainfall intensity, duration, frequency dictate the amount that can infiltrate into the soil. The soil properties which influence the effectiveness of rainfall are infiltration characteristics, water holding capacity, moisture content at the time of rainfall, etc. Crop rooting depth and water use rate determine the capacity of soil moisture reservoir and its depletion rate on which the effectiveness of rainfall depends. Crop covers and characteristics of the ground surface, slope, irrigation methods used, cultivation

practices are all influent on the value of effective rainfall.

Since the cultivation characteristics of field and vegetable crops are completely different from that of paddy field, determination of effective rainfall for these two types of crops will be considered separately.

8.1 Effective rainfall for field and vegetable crops. Perhaps the most widely used method for estimating effective rainfall for field and vegetable crops is that developed by U.S. Department of Agriculture, Soil Conservation Service (1970) as presented in Table 13. The table has been developed to show the relationship between monthly effective rainfall and the three variables; monthly rainfall, consumptive use rate and the storage capacity of soil moisture reservoir. The effective storage capacity was assumed to be 75 mm for the values of monthly effective rainfall presented in the Table. Correction factors are provided for different soil moisture holding capacity.

Example 6

Given monthly rainfall of 150 mm; crop evapotranspiration, E_T^c , of 175 mm. and effective storage of 125 mm., determine the effective rainfall.

Calculation

| | | | |
|---|---|-------------------|------------|
| Effective rainfall from the Table 13 | = | 110 | mm. |
| Correction factor for effective storage | = | 1.04 | |
| Then, monthly effective rainfall | = | 110×1.04 | mm. |
| | = | <u>114.4</u> | <u>mm.</u> |

8.2 Effective rainfall for paddy field. There are many methods available for estimating effective rainfall for paddy field. Most of these methods were developed by applying water balance equation to the storage capacity of paddy fields. The estimated effective rainfall, therefore, depends on the local cultural practices, rainfall characteristics, crop growth stages as well as irrigation practices in the area. An example of effective rainfall curve for

Table 13 Average monthly effective rainfall (R_e) as related to mean monthly rainfall and average monthly consumptive use.

| Monthly mean Rainfall mm | Average Monthly Consumptive Use (ET) mm. | | | | | | | | | |
|-----------------------------|--|-----------|-----------|------------|------------|------|------|------|------|------|
| | 25 | 50 | 75 | 100 | 125 | 150 | 175 | 200 | 225 | 250 |
| | Average Monthly Effective Rainfall (R_e) mm. | | | | | | | | | |
| 15 | 9 | 10 | 10 | 11 | 11 | 12 | 12 | 13 | 14 | 15 |
| 20 | 12 | 13 | 14 | 14 | 15 | 16 | 17 | 18 | 19 | 20 |
| 30 | 18 | 19 | 21 | 22 | 22 | 23 | 24 | 26 | 28 | 30 |
| 40 | 23 | 25 | 27 | 29 | 30 | 31 | 32 | 35 | 38 | 40 |
| 50 | <u>25</u> | 32 | 34 | 35 | 36 | 38 | 40 | 43 | 46 | 49 |
| 60 | | 38 | 40 | 42 | 43 | 45 | 47 | 51 | 55 | 59 |
| 70 | | 43 | 46 | 49 | 51 | 53 | 55 | 59 | 63 | 68 |
| 80 | | 48 | 52 | 55 | 58 | 60 | 63 | 67 | 71 | 77 |
| 90 | | <u>50</u> | 57 | 61 | 64 | 67 | 70 | 75 | 79 | 85 |
| 100 | | | 63 | 67 | 71 | 74 | 78 | 82 | 87 | 94 |
| 110 | | | 68 | 73 | 78 | 80 | 84 | 89 | 95 | 102 |
| 120 | | | 73 | 78 | 84 | 86 | 91 | 97 | 102 | 110 |
| 130 | | | <u>75</u> | 83 | 89 | 92 | 98 | 104 | 110 | 116 |
| 140 | | | | 89 | 95 | 99 | 105 | 112 | 116 | 126 |
| 150 | | | | 94 | 101 | 105 | 110 | 120 | 125 | 134 |
| 160 | | | | 99 | 106 | 110 | 117 | 125 | 132 | 142 |
| 170 | | | | <u>100</u> | 111 | 116 | 123 | 131 | 138 | 149 |
| 180 | | | | | 116 | 121 | 129 | 136 | 144 | 165 |
| 190 | | | | | 121 | 126 | 134 | 142 | 150 | 166 |
| 200 | | | | | <u>125</u> | 132 | 140 | 148 | 157 | 166 |
| Effective Storage | 20 | 30 | 40 | 50 | 60 | 75 | 100 | 125 | 150 | 175 |
| Storage Factor | 0.74 | 0.82 | 0.88 | 0.93 | 0.96 | 1.00 | 1.02 | 1.04 | 1.06 | 1.07 |

Note: Average monthly effective rainfall cannot exceed average monthly rainfall or average monthly consumptive use. When the application of the above factors results in a value of effective rainfall exceeding either, this value must be reduced to a value equal the lesser of the two.

paddy developed for the north-eastern region of Thailand is presented in Fig. 14.

9. Leaching Requirement

Leaching requirement is a fraction of irrigation water that must be leached through the root zone to control soil salinity at any specified level.

Irrigation water may contains from 0.1 to 4 metric tons of salts per hectare-meter. When it is applied to soil, these salts are added to those already present in the soil and the salt concentration increases. Without removal the accumulation of salts may increase to the level that it is harmful to the crops and the yields will decrease.

Salt concentration in the root zone can be removed by applying enough water through the soil profile to dissolve the soluble salts and to transport them by downward movement from the crop root zone. The process is known as leaching. In humid and subhumid areas, rain water usually passes through the soil in sufficient quantities to dissolve and remove salt accumulation and thus leaching is seldom required. In arid and semi-arid areas, on the other hand, irrigation water and soils normally contain higher concentration of salts but rainfall is insufficient to leach them out of the soils. Leaching of excess salts in these regions, therefore, is usually a necessity if high crop production is to be sustained.

The leaching requirement can be determined from the formula:

$$LR = \frac{D_i EC_i}{(D_r + D_i) EC_d} \dots\dots\dots (18)$$

- where LR = leaching requirement,
 D_i = depth of irrigation water required to satisfy both crop evapotranspiration and leaching requirement in mm,
 D_r = depth of rainwater entering the soil profile in mm,

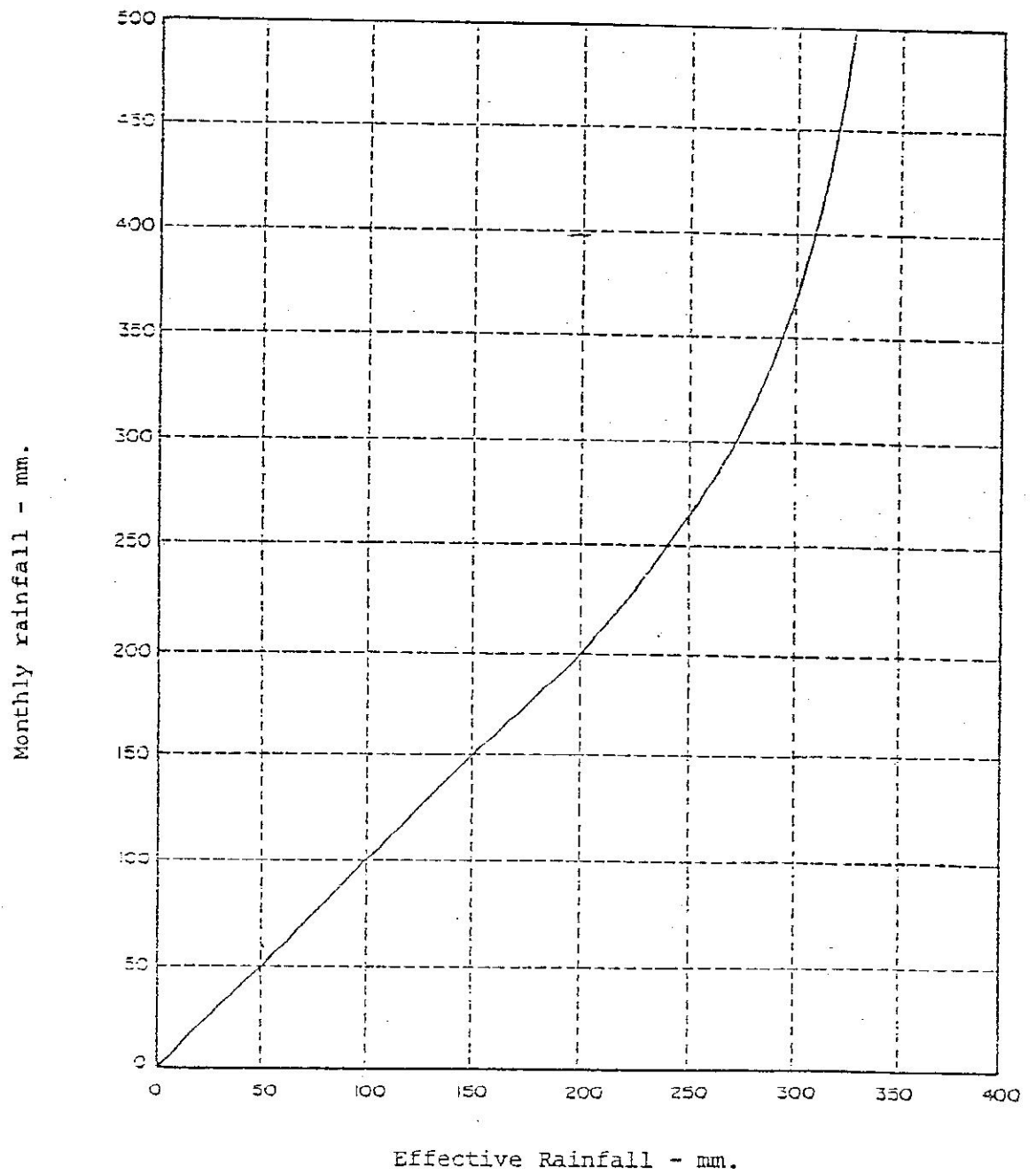

Fig. 14 Effective rainfall curve for paddy developed for north-eastern region of Thailand by Engineering Consultants, Inc.

EC_i = electrical conductivity of irrigation water in millimho per centimeter,

EC_d = maximum permissible electrical conductivity of drainage effluence for the crop being irrigated in millimho per centimeter.

10. Water Requirements for Paddy Field

In determining water requirements for paddy, there are few components which are not taken into account in estimating water requirements for field or vegetable crops, including percolation loss, land preparation and nursery requirements.

10.1 Percolation loss Unlike field crops, percolation loss in a paddy field is unavoidable and must be treated as a requirement. Percolation loss from paddy field depends on the soil texture, depth to groundwater table and the present of hard pan which is commonly found in a paddy field. The range of this loss may vary from less than 1.0 mm/day in heavy clay soils to as much as 6.0 mm/day in light soils. However, rice cultivation is not recommended where the loss exceeds 5 mm/day because irrigation in such area would require too large water distribution system to be economically justified.

10.2 Land preparation Preparing land for transplanted rice usually requires considerable amount of water which sometimes exceeds the peak evapotranspiration requirements for the crop itself. This requirement consists of water that need for top soil saturation, percolation and evaporation losses during the preparation period, and that need for standing water. Generally, land preparation requirement for paddy may range from 200 mm to 350 mm or more.

10.3 Nursery bed Preparing a nursery bed is, more or less, the same as land preparation for the transplanting but more water is needed for consumptively uses of seedlings and percolation loss during the crop development. These extra requirements range from 200 to 250 mm and make a total requirements for the nursery bed of

400 to 600 mm. However, the area for nursery bed is only 3 to 6 percent of the paddy field and the water requirement for this purpose will be reduced to 25 to 40 mm when spread over the entire field.

In summary, the water requirements for paddy field consists of evapotranspiration plus percolation loss which is normally accounted for 1 to 3 mm/day, plus land preparation requirement of 200 to 350 mm and 25 to 40 mm for nursery bed at the starting of growing season.

11. Irrigation Efficiency

After the net irrigation requirements has been calculated, the unavoidable losses need to be known to determine the project water requirement. The losses are operation, conveyance, storage and application losses.

The operation losses are those incurred during the delivery operation. Examples of such losses are diversion in excess of the demand, loss in filling the canals and ditches at the starting of a rotational delivery, leakage from the gate or other water control structures, etc. at headworks.

Conveyance losses in an irrigation system come from three sources: (1) seepage from the canal, (2) evaporation from water surface and consumptive use by aquatic weeds in the canal, and (3) leakage through and around water control structures in the canals and ditches.

In some irrigation scheme, farm ponds or irrigation reservoirs may be needed to store water during the period of excess period of deficit, to meet the farm requirements during the period of deficit. The need may also come from receiving too small stream to operate the irrigation system or apply to the field efficiently. When the water is stored in a reservoir, the evaporation and seepage losses will incur.

Losses during water application are determined mainly by irrigation method. In surface irrigation, the losses probably come from surface runoff and deep percolation. When sprinkler irrigation is used, the losses are evaporation and wind drifting of the droplets to non-cropped area.

The magnitude of all losses discussed above can be evaluated in the field with acceptable accuracy. However, these data are not available during planning stages and usually have to base on measurements from similar projects. The losses from irrigation system, usually expressed in terms of efficiency, are normally subdivided into three stages, each of which is affected by different set of conditions:

(1) Conveyance efficiency (E_c): the ratio between volume of water received at inlet of a block of fields to the volume of water diverted into the conveyance system at the headwork or supply source.

(2) Field canal efficiency (E_b): the ratio between volume of water received at the field inlet to the volume of water received at the inlet of the block of field.

(3) Field application efficiency (E_a): the ratio between volume of water available for beneficially use by crop to the volume of water received at the field inlet.

(4) Project efficiency (E_p): the ratio between volume of water available for beneficially use by crop to the volume of water diverted into the conveyance system at the headwork.

$$E_p = E_a \cdot E_b \cdot E_c \dots\dots\dots (19)$$

Some data of irrigation efficiency are presented in Table 14. Some water requirement assumptions for operation of Nong Wai Project, Thailand, are presented in Table 15.

Table 15 Water requirement assumptions for operation of the Nong Wai Project, Thailand

| Item | RID 1/ | | Sanyu 2/ | | SCG 3/ | | ADB Recommendation |
|---|--|--|---|---|---|---|---------------------------------|
| | Blaney Criddle method | Blaney Criddle method | Blaney Criddle method | Blaney Criddle method | Blaney Criddle method | Blaney Criddle method | |
| 1. Consumptive use | Dry season 3.0 mm/day Wet season 2.0 mm/day | Computed from actual daily reading unit as practiced in Taiwan Wet season 627 mm Dry season 216 mm | Heavy soils 1.5 mm/day Sandy soils 3.0 mm/day | Heavy soils 1.5 mm/day Loamy and sandy soils 3.0 mm/day | Heavy soils 1.5 mm/day Loamy and sandy soils 3.0 mm/day | Heavy soils 1.5 mm/day Loamy and sandy soils 3.0 mm/day | Same |
| 2. Percolation rate | Computed from actual daily reading unit as practiced in Taiwan Wet season 627 mm Dry season 216 mm | Computed by carry over system for 10 days Wet season 516 mm Dry season - nil - | Computed by carry over system for each 10 days Wet season 489 mm Dry season -nil- | Computed by carry over system for each 10 days Wet season 489 mm Dry season -nil- | Computed by carry over system for each 10 days Wet season 489 mm Dry season -nil- | Computed by carry over system for each 10 days Wet season 489 mm Dry season -nil- | Adopt |
| 3. Effective rainfall | Wet season 627 mm Dry season 216 mm | Wet season 50% Dry season 60% | Wet season 60% Dry season 60% | Wet season 50% Dry season 50% | Wet season 50% Dry season 50% | Wet season 409 mm Dry season 30 mm | Adopt same as Sanyu |
| 4. Project Irrigation efficiency | Wet season 250 mm Dry season 300 mm. | Wet season 200 mm Dry season 200 mm. | Wet season 200 mm Dry season 200 mm. | Wet season 200 mm Dry season 200 mm. | Wet season 200 mm Dry season 200 mm. | Wet season 409 mm Dry season 30 mm | Same as Sanyu |
| 5. Water requirement for land soaking and preparation | 60 days | 60 days | 60 days | 60 days | 60 days | Wet season = 70 days (10 weeks) | Wet season = 70 days (10 weeks) |
| 6. Cropping intensity | Rice 100% Rice 80% | Rice 100% Rice 80% | Rice 100% Rice 80% | Rice 100% Rice 80% | Rice 100% rice 80% | Dry season = 63 days (9 weeks) | Dry season = 63 days (9 weeks) |
| 7. Wet season | 16 Jun.-30 Nov. 160 days | 1 Jun.-31 Oct. 153 days | 1 Jun.-31 Oct. 153 days | 11 Jun.-20 Nov. 163 days | 11 Jun.-20 Nov. 163 days | Rice 98%, Veg. 2% | Rice 98%, Veg. 2% |
| 8. Dry season | 16 Dec.-15 May. 151 days | 21 Dec.-20 May. 151 days | 21 Dec.-20 May. 151 days | 21 Dec.-20 May. 151 days | 21 Dec.-20 May. 151 days | Rice 70%, Veg. 4% | Rice 70%, Veg. 4% |
| 9. Irrigation period | | | | | | Other crops 6% | Other crops 6% |
| 10. Wet season | | | | | | 1 Jun.-1 Nov. 154 days | 1 Jun.-1 Nov. 154 days |
| 11. Dry season | | | | | | 1 Dec.-12 Apr. 133 days | 1 Dec.-12 Apr. 133 days |

Sources:

- 1/ Irrigation Water requirement (Nam Pong and Nong Wai Projects), Royal Irrigation Department, Thailand, February 1982
- 2/ Study report on Improvement of Main Irrigation System of Nong Wai Pioneer Agriculture Project, Sanyu Consultant Inc., Nagoya, Japan, July 1981
- 3/ Draft final Report on Ubolratana Dam Flood Protection Study for EGAT by Salzgitter Consult GmbH, March 1982.

References

- Blaney H.F. and Criddle W.D. 1950, Determination of Water Requirements in Irrigated Areas from Climatological and Irrigation Data, USDA (SCS) TP-96, 48 p.
- Boonyatharekul, W., 1987, Evapotranspiration and Irrigation Water Requirements, Training Course on : Planning and Design of Small Scale Irrigation Project, Asian Institute of Technology, June-July.
- BOS M.G. and J. Nugteren, 1974, On Irrigation efficiencies Publication 19, International Institute for Land Reclamation and Improvement, The Netherlands.
- Chang Jen-Hu, 1968, Climate and Agriculture : An Ecological Survey, Aldine Publishing Company, Chicago.
- The Consultants for Nong Wai Irrigation Management Project, 1983, Operation Manual for Irrigated Agriculture in Nong Wai Pioneer Agricultural Project, Royal Irrigation Department, Thailand.
- Doorenbos J. and Pruitt W.O., 1977 and 1984, Crop Water Requirements, FAO Irrigation and Drainage Paper 24, FAO, Rome.
- Gangopadhaya, G., E. Harbeck, T.J. Nordenson, H.M. Omar, V.A. Uryvaev, 1966, Measurement and Estimation of Evaporation and Evapotranspiration. Technical Note No. 83 World Meteorological Organization, Geneva, Switzerland.
- Hanks R.J. and R.W. Shaweroff, 1965, An Economical Lysimeter for Evapotranspiration Studies, Agron. J. 57: 634-636.
- Jensen M.E. (Ed.), 1973, Consumptive Use of Water and Irrigation Water Requirements., Am. Soc., Civ., Engr., New York.

- King K.M., C.B. Tanner, and V.E. Suomi, 1956, A Floating Lysimeter and Its Evaporation Recorder, Trans, Am, Geophys, Union. 37(6) : 738-742.
- Penman H.L., 1948, Natural Evaporation from Open Water, Bare Soil and Grass, Proc. Roy. Soc, London, A 193 : 120-120.
- Penman H.L., 1956, Evaporation : An Introductory Syrvey, Netherlands J. Agr. Sci, 1 : 9-29.
- Pruitt, W.O. and D.E. Angus, 1960, Large Weighing Lysimeter for Measuring Evapotranspiration, Trans.of the ASAE 3(2) : 13-18.
- USDA (SCS), 1970, Irrigation Water Requirements, Technical Release No. 21, U.S. Department of Agriculture, Soil Conservation Service.
- USDA (SCS) 1964, Irrigation, SCS National Engineering Handbook Section 15, Chapt. 1 : Soil-Plant Water Relationships, U.S. Government Printing Office, Washington D.C.

IRRIGATION DESIGN AND MANAGEMENT
TRAINING COURSE
Package II: IRRIGATION PRINCIPLES

By

THE ROYAL IRRIGATION DEPARTMENT
in cooperation with
KASETSART UNIVERSITY

AUGUST 1987

Training Course : IRRIGATION DESIGN AND MANAGEMENT
(Irrigation Principles)

IRRIGATION SCHEDULING

By

Dr. Varawoot Vudhivanich
Assistant Professor

Dept. of Irrigation Engineering
Kasetsart University

Faculty of Engineering
Kamphaengsaen Campus

Nakorn Pathom 73140

Contents

| | |
|---|----|
| 1. Introduction | 1 |
| 2. Effects of Irrigation on Yield | 1 |
| 3. Effect of Irrigation on Crop Quality | 2 |
| 4. Factors Affecting Irrigation Scheduling | 4 |
| 4.1 Conditions for relatively frequent irrigations | 4 |
| 4.2 Conditions for relatively infrequent irrigations | 6 |
| 5. Irrigation Scheduling Criteria | 7 |
| 5.1 Subsistence economy | 7 |
| 5.2 Competitive Economy | 9 |
| 6. Methods for Scheduling Irrigations | 9 |
| 6.1 Irrigation Scheduling by Crop Appearance | 9 |
| 6.2 Irrigation Scheduling by Soil Moisture Measurements | 9 |
| 6.3 Irrigation Scheduling Based on Moisture Accounting Method. | 18 |
| References. | 21 |

IRRIGATION SCHEDULING

1. Introduction

Irrigation scheduling may be defined as a decision making process by which the amount and time of irrigation is determined so that the yield, in terms of both quality and quantity, is maximized. The key to this decision making is the understanding of the relationship between water and yield, i.e., at which moisture level water should be applied to obtain the maximum yield, and what would be the yield loss if the water applied is inadequate.

2. Effects of Irrigation on Yield

The soil moisture level that must be maintained for optimum yield and quality varies with crop varieties and climatic conditions. Most plants can extract sufficient water for maximum growth if the soil moisture is maintained at a level close to field capacity. As soil moisture decreased, the soil moisture tension increases and the plants have to use more and more force to extract the same amount of water. If the soil moisture is not restored by irrigation or rainfall, eventually the water uptake by plant roots will not be sufficient to meet evaporative demand dictated by climatic conditions. The plants begin to wilt and growth is retarded or completely stopped.

When the water uptake by plant roots does not satisfy the crop water requirements, the actual evapotranspiration of that crop will fall below maximum evapotranspiration. Under this condition, the crop is said to be under "stress" which growth and yield will be affected. The effect of water stress on growth and yield depends on the crop types and varieties, the magnitude and duration of water stress, and the growth stage at which the stress occurs.

Numerous research results have shown that dry matter production is proportional to the amount of water transpired. This is particularly true during the period when the plants are actively

growing. Maintaining high level of moisture in soil will insure rapid leaf development in young crop and maximum photosynthesis when the crop is fully developed. Therefore, for crop whose yield depends wholly, or in large part, on vegetative growth stage such as lettuce, celery, cauliflower, tobacco, grass, and other vegetable crops, the maximum yield is usually obtained by maintaining the soil moisture close to field capacity. For these crops, the maximum evapotranspiration must be used for determining the amount and time of water application.

Crops have different levels of tolerance to the depletion of soil moisture before irrigation. Some crops such as sweet potatoes, grasses, and most vegetable crops response favorably to frequent irrigations and may suffer if more than 40 to 50 percent of available moisture in the soil is depleted before irrigation is applied. Other crops, such as tomatoes, potatoes, peanuts, small grains (especially during maturity stage), fruit trees and a number of crops which develop deep and well rooted systems, may show little reduction in yield until most of the available moisture has been depleted from the root zone.

When a water deficit occurs during any growing period of a crop, the reduction in yield can vary greatly depending on how sensitive the crop is at that growth period. For example, moisture level studies at Prosser, Washington showed that depletion of moisture to the wilting point markedly depressed yields of corn. A moisture deficit for 1 or 2 days during the tasseling or pollination period reduced yields by as much as 22 percent. A moisture deficit for 6 or 8 days reduced yields by 50 percent. For most crops there are critical periods in the growing season when a high moisture level must be maintained for high yields. The critical period for a number of commonly irrigated crops is presented in the Table 1.

3. Effect of Irrigation on Crop Quality

As discussed in the preceding section, dry matter production is related to the amount of water transpired. However, this is

Table 1 Sensitive Growth Periods for Water Deficit (Critical Period)
(Doorenbos and Kassam, 1979)

| | |
|-------------|---|
| Alfalfa | just after cutting (and for seed production at flowering) |
| Banana | throughout but particularly during first part of vegetative period, flowering and yield formation |
| Bean | flowering and pod filling; vegetative period not sensitive when followed by ample water supply |
| Cabbage | during head enlargement and ripening |
| Citrus | |
| grapefruit | flowering and fruit set > fruit enlargement |
| lemon | flowering and fruit set > fruit enlargement; heavy flowering may be induced by withholding irrigation just before flowering |
| orange | flowering and fruit set > fruit enlargement |
| Cotton | flowering and boll formation |
| Grape | vegetative period, particularly during shoot elongation and flowering > fruit filling |
| Groundnut | flowering and yield formation, particularly during pod setting |
| Maize | flowering > grain filling; flowering very sensitive if no prior water deficit |
| Olive | just prior flowering and yield formation, particularly during the period of stone hardening |
| Onion | bulb enlargement, particularly during rapid bulb growth > vegetative period (and for seed production at flowering) |
| Pea | flowering and yield formation > vegetative, ripening for dry peas |
| Pepper | throughout but particularly just prior and at start of flowering |
| Pineapple | during period of vegetative growth |
| Potato | period of stolonization and tuber initiation, yield formation > early vegetative period and ripening |
| Rice | during period of head development and flowering > vegetative period and ripening |
| Safflower | seed filling and flowering > vegetative |
| Sorghum | flowering yield formation > vegetative; vegetative period less sensitive when followed by ample water supply |
| Soybean | yield formation and flowering; particularly during pod development |
| Sugarbeet | particularly first month after emergence |
| Sugarcane | vegetative period, particularly during period of tillering and stem elongation > yield formation |
| Sunflower | flowering > yield formation > late vegetative, particularly period of bud development |
| Tobacco | period of rapid growth > yield formation and ripening |
| Tomato | flowering > yield formation > vegetative period, particularly during and just after transplanting |
| Water melon | flowering, fruit filling > vegetative period, particularly during vine development |
| Wheat | flowering > yield formation > vegetative period; winter wheat less sensitive than spring wheat |

not necessary so for quality of an agricultural product and yield because water deficit may retard vegetative growth but may have little effect on the economical yield.

The quality of a crop is influenced by temperature, radiation, and length of the total growing season in addition to cultural practices such as fertilizer application, allowable depletion, and control of plant diseases. However, in the case where certain compounds of plant such as sugar, rubber and tobacco, are the required quality, moderate moisture stress has often been found to be desirable.

For example during the ripening period, irrigation interval of sugarcane should be extended or stopped to dehydrate the cane and force the conversion of total sugar to recoverable sucrose. A mild water deficit during the ripening period of tobacco is desirable to restrict the growth of new young leaves. Excess water during the yield formation and ripening period will result in low quality leaves.

Effects of irrigation on yield quality of some crops are presented in Table 2.

4. Factors Affecting Irrigation Scheduling

There are many factors involved in determining irrigation scheduling. These factors can be divided into four main groups: (1) plant, (2) soil, (3) climatic and (4) management factors. Based on these factors, Hagen et. al. (1967) have summarized conditions which require relatively frequent irrigations for maximum crop yields and conditions which permit relatively infrequent irrigations as follows.

4.1 Conditions for relatively frequent irrigations:

(1) Plant

- Shallow, sparse, slow-growing roots.
- Major growth occurs during rainless season and/or periods of high evaporative demand.
- Fresh weight yield of vegetative organ desired.

Table 2 Effect of Irrigation on Crop Quality (Chang, 1968)

| <i>Crop</i> | <i>Effect</i> | <i>Reference</i> |
|-----------------|---|---|
| Pasture | Irrigation increased the protein and decreased the fat contents of the herbage but had little effect on the crude fiber and ash content. | Turley, Webster, and Carson (1963) |
| Vegetable crops | Maintaining a low moisture stress during the whole growth period generally resulted in the highest yield and quality. | Bierhuizen and de Vos (1959) |
| Snap beans | Irrigation decreased the percentage of pods that were badly crooked or severely malformed. Fibrous content of beans was generally reduced. | Vittum, Alderfer, Janes, Reynolds, and Struchtemeyer (1963) |
| Sweet corn | Irrigation significantly increased the number of marketable ears per plants, the average weight per ear and the gross yield of unhusked ears and the percentage of usable corn cut from these ears for canning or freezing. | Vittum, Alderfer, Janes, Reynolds, and Struchtemeyer (1963) |
| Soybeans | Irrigated soybeans had slightly lower oil content and slightly higher protein content. | Schwab, Shrader, Nixon, and Shaw (1958) |
| Barley | Irrigation significantly increased the yield of grain and improved malting quality, mainly by increasing extract. | Bendelow (1958) |
| Potatoes | Irrigation that gave good increase in yield of potatoes very seldom reduced the specific gravity and was more likely to increase it. | Jacob, Russell, Klute, Levine, and Grossman (1952) |
| Tobacco | Irrigated tobacco had lower nicotine and protein, but higher carbohydrate content. | Anita (1949) |
| Tobacco | Adequate irrigation meant lower content in the cured leaves for nicotine, total nitrogen, CaO and MgO, but higher content for sugars, as well as better burning characteristics, high yield and higher market value. | van Bavel (1953a) |
| Tobacco | Irrigation produced higher yields of leaves of satisfactory quality. | Lovett (1953) |
| Fruits | Canned peaches that were tough and leathery in texture, pears that remained green and hard a week or more after the ripening season, prunes that were sunburned, and walnuts with partly filled shells were some of the results of a relatively long time without readily available moisture. | Veihmeyer and Hendrickson (1956) |
| Cantaloupes | Heavier irrigation increased cull fruits associated with increased vine growth and succulence. | Flocker, Lingle, Davis, and Miller (1965) |
| Olives | The higher yield obtained by irrigation is due to an increase in fruit size, rather than in the number of fruits. Irrigated groves have a higher oil content than unirrigated ones. | Sannish and Spiegel (1961) |

(2) Soil

- Shallow soil; poor structure impeding root growth.
- Slow infiltration and internal drainage, poor aeration.
- Root diseases, nematodes present.
- Small fraction of available water held at low suctions.
- Saline soils and/or saline irrigation water.
- High Fertility level; nutrients concentrated in top soil.
- Very high soil temperature with shallow rooted crops.

(3) Climatic conditions

- High evaporative rates.
- No rainfall during the growing season.

(4) Management

- Planted at beginning of hot dry weather.
- Maximum yield desired even though maturation may be retarded.
- Market value dependent on total fresh weight yield or size of harvested organ.

4.2 Conditions for relatively infrequent irrigations:

(1) Plant

- Deep, dense, fast-growing roots.
- Xerophytic characteristics.
- Major growth occurs during rainy season and/or periods of low evaporative demand.
- Dry weight yields of reproductive organ desired.

(2) Soil

- Deep soil, good structure.
- Good infiltration, internal drainage, aeration.
- Large fraction of available water held at low suctions.

- Nonsaline
 - Low fertility level, nutrients distributed in profiles.
 - Constant water table in reach of roots.
- (3) Climatic conditions
- Low evaporative rates.
 - Rain during growing season.
- (4) Management
- Planted and grown during rainy season and/or periods of low evaporative demand.
 - Planted and well established before hot dry weather.
 - Early maturation required to achieve harvest of favorable marketing even though yield may be somewhat depressed.
 - Market value determined by total dry weight, percentage dry weight or content of specific constituent.

5. Irrigation Scheduling Criteria

Criteria for irrigation scheduling vary from one situation to another. Generally, there are two constraints which influence setting the criteria: limited land area and limited water availability. These two cases have to be considered separately in subsistence economy or under-developed areas and in competitive economy areas.

5.1 Subsistence conomy In under-developed or some developing areas, the goal of irrigation usually aim at maximizing total gross product with little attention paid to the production costs. Therefore, when the water resource is not limited, irrigation should be schedule to maximize crop production per unit of planted area.

If the water supply is scarce or expensive, the area that can be irrigated is inversely proportional to the water applied. Under this condition, the irrigation should be schedule to maximize

crop production per unit of applied water. To determine the optimum volume of applied water per unit area, it is necessary to know the exact shape of crop response function to different quantity of water used by the crop throughout its growth cycle. The optimum water allocation of both cases based on crop yield-water use function or production function is presented in Fig. 1. The point A on the production function corresponds to the conditions where the land area is limited and point B corresponds to the optimum water applied and expected yield when the water is limited.

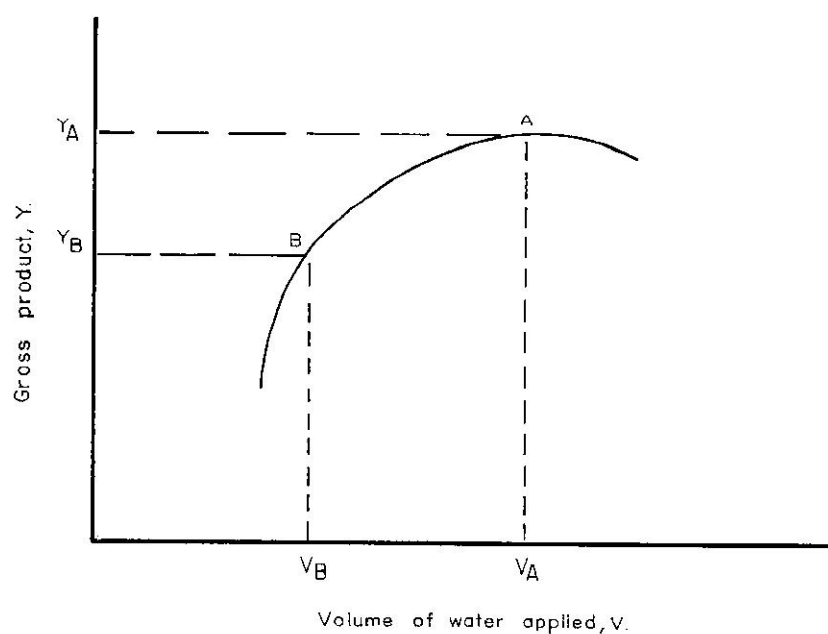

Fig. 1 Production function and optimum water allocation under subsistence economy conditions.

5.2 Competitive Economy Under competitive economy condition, the objective of irrigation is to maximize the net income from irrigated crops. Therefore, all the production costs such as cost of water per unit volume, operation and maintenance costs of the irrigation system, expenditure on soil preparation, harvesting, fertilizer, labor, etc., as well as the gross income of the area from irrigation must be taken into consideration. The optimum volume of water to apply will correspond to the volume where the difference between the gross income and production costs is maximum.

6. Methods for Scheduling Irrigations

Where the water is available on demand, the following approaches may be used to schedule irrigation:

- (1) Crop appearance
- (2) Soil moisture measurements
- (3) Evapotranspiration rate

6.1 Irrigation Scheduling by Crop appearance

There are many indicators can be observed when the plant is under water stress. The most obvious sign is its wilting, and colour change in the plant foliage. Temporary wilting may occur during the hot and windy day even when the soil is still relatively wet. Crop appearance varies in its significance on irrigation need from crop to crop. Scheduling irrigation based on crop appearance alone could be dangerous because some plants may not show any wilting or other signs until growth has been seriously retarded or some other injury has occurred.

6.2 Irrigation Scheduling by soil Moisture Measurements

The most direct and effective method of determining when to irrigate is to measure or to estimate the soil moisture periodically before irrigation. Based on this information and allowable soil moisture depletion at particular crop growth stages, the time and depth of irrigation can be accurately determined.

Table 3 Practical interpretation chart of soil moisture for various soil textures and conditions

| Available moisture in soil | Feel or appearance of soil | | | | Fine and very fine textured soils |
|----------------------------------|--|---|--|--|---|
| | Coarse-textured soils | Moderately coarse textured soils | Medium-textured soils | | |
| 0 percent---- | Dry, loose, and single-grained; flows through fingers. | Dry and loose; flows through fingers. | Powdery dry; in some places slightly crusted but breaks down easily into powder. | | Hard, baked, and cracked; has loose crumbs on surface in some places. |
| 50 percent or less. | Appears to be dry; does not form a ball under pressure. ^{1/} | Appears to be dry; does not form a ball under pressure. ^{1/} | Somewhat crumbly but holds together under pressure. | | Somewhat pliable; balls under pressure. ^{1/} |
| 50 to 75 percent. | Appears to be dry; does not form a ball under pressure. ^{1/} | Balls under pressure but seldom holds together. | Forms a ball under pressure; somewhat plastic; slicks slightly under pressure. | | Forms a ball; ribbons out between thumb and forefinger. |
| 75 percent to field capacity. | Sticks together slightly; may form a very weak ball under pressure. | Forms weak ball that breaks easily; does not slick. | Forms ball; very pliable; slicks readily if relatively high in clay. | | Ribbons out between fingers easily; has a slick feeling. |
| At field capacity (100 percent). | On squeezing, no free water appears on soil but wet outline of ball is left on hand. | Same as for coarse-textured soils at field capacity. | Same as for coarse-textured soils at field capacity. | | Same as for coarse-textured soils at field capacity. |
| Above field capacity. | Free water appears when soil is bounced in hand. | Free water is released with kneading. | Free water can be squeezed out. | | Puddles; free water forms on surface. |

^{1/} Ball is formed by squeezing a handful of soil very firmly.

There are many methods that can be used to measure and estimate the soil moisture: some are relatively simple and do not require expensive equipments, others are strictly suitable for research work. The methods and instruments which are commonly used in irrigation scheduling which will be discussed are the soil appearance and feel, tensiometer, and electrical resistance instruments.

(1) Appearance and feel method By taking soil samples from representative locations and to a depth cover the major part of the root zone and comparing with descriptions in a guide as shown in Table 3, the available moisture remaining in the root zone can be estimated. The only equipment required in this method is the soil auger, therefore, it is one of the cheapest. However, it requires a lot of work to get soil samples. The method may not be very accurate but with experience and judgement the irrigator should be able to estimate the moisture level in the soil within acceptable range of accuracy for irrigation scheduling purpose.

(2) Tensiometer Tensiometer is an instrument for measuring soil moisture tension which is an indicator of the amount of available moisture. It is a closed tube filled with water which bottom is made of porous ceramic cup. A gage or device for measuring vacuum is attached just below the stopper. The scale of the gage are generally calibrated in either hundredths of an atmosphere or in centimeters of water. The tube is installed in soil with the ceramic tip located at the desired depth. The tube is long enough for the stopper and gage to remain above ground. A schematic sketch of tensiometers is presented in Fig. 2.

After installed, the tube is filled with water. Water moves through the porous wall and create a partial vacuum inside the tube until the vacuum is in equilibrium with the soil suction. The soil suction which can be read from the gage will change corresponding to moisture change in the soil. The tensiometer reading increases as the soil dried and decreases when the soil is irrigated and water is flow n back into the tensiometer by the vacuum.

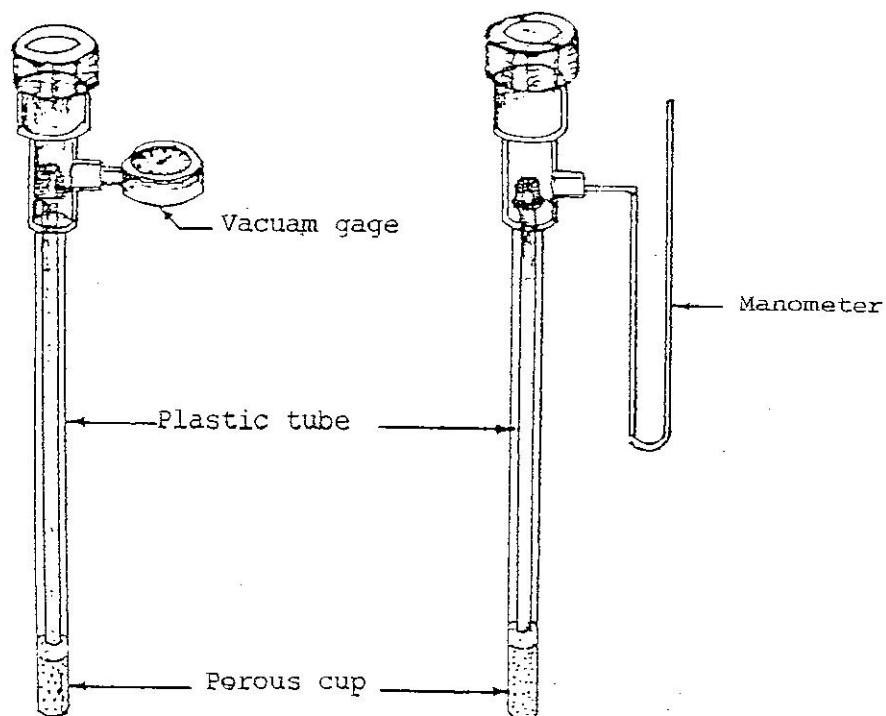

Fig. 2 Schematic sketch of tensiometers

Most tensiometer gage are calibrated with reading from 0 to 100 centibars. One hundred centibars equal one bar which is about the same as a standard atmospheric pressure. The tensiometer continues to record fluctuations in soil-water content unless the tension exceeds in centibars, at which point air enters the system, and the instrument ceases to function. Within its measuring range, interpretation of the reading are as follows:

| Reading | Interpretation |
|---------|--|
| 0 | The soil is saturated where plant roots will suffer from lack of oxygen. |
| 0-5 | The soil is wet for most crops. |
| 10-25 | Ideal moisture and aeration conditions. |

| Reading | Interpretation |
|---------|--|
| > 25 | Water deficiency may occur for sensitive plants or plants having shallow root systems including potted plants or plants growing in coarse textured soil. |
| 40-50 | Most field crops having root systems 50 cm deep or more will not suffer from lack of water. |
| 70 | Plants having good root systems 75 cm deep or more in medium textured soils will not suffer from shortage of water. In medium to moderately fine-textured soils, plants having well developed deep root system may not need irrigation for several days after reading passed 70. |
| 80 | Most soils will be dry enough to require irrigation even though the plant may not show any symptoms of stress. |

Soil moisture suction at which water should be applied for maximum yield for various crops as compiled by Taylor (1965) is presented in Table 4.

Tensiometer readings do not provide direct information on the amount of water remaining in the soil but give relative wetness around the porous cup in term of soil moisture tensions. Tensiometer, therefore, is used as an indicator on when to irrigate but not on how much water should be applied. However, if tensiometers are placed in the active root zone and near the bottom of root zone, the readings during irrigation can provide information on the wetted depth as illustrated in Fig. 3. In this example, water was applied when tensiometer reading at 12 inches depth approaching 50 centibars but the amount was not large enough to wet down to 24 inches level. When the duration of application was increased to 7 hours, the soil moisture suction at the lower depth decreased indicating the water reached the

Table 4 Soil water suction at which water should be applied for maximum yields of various crops grown in deep, well drained soil fertilized and management for maximum production (adapted from Taylor, 1965)*

| Crop | Soil suction, bars | Literature reference |
|--|--------------------|---|
| <u>Vegetative crops</u> | | |
| Alfalfa | 1.50 | S. A. Taylor & associates, Logan, Utah |
| Beans (snap, lima) | 0.75 - 2.00 | Vittum et al. (1963) |
| Cabbage | 0.60 - 0.70 | Vittum et al. (1963) Pew (1958) |
| Canning peas | 0.30 - 0.50 | S. A. Taylor & associates, Logan, Utah |
| Celery | 0.20 - 0.30 | A. W. Marsh, personal communication Marsh (1961) |
| Grass | 0.30 - 1.00 | Vissar (1959) |
| Lettuce | 0.40 - 0.60 | A. W. Marsh, personal communication Vissar (1959) Pew (1958) |
| Tobacco | 0.30 - 0.80† | Jones et al. (1960) |
| Sugar cane | 0.25 - 0.30 | Anon. (1954) |
| Sweet corn | 0.50 - 1.00 | S. A. Taylor & associates, Logan, Utah Vittum et al. (1963) |
| <u>Root crops</u> | | |
| Onions, early | 0.45 - 0.55 | Pew (1958) |
| Onions, bulbing | 0.55 - 0.65 | Pew (1958) |
| Sugar beets | 0.40 - 0.60 | S. A. Taylor & associates, Logan, Utah |
| Potatoes | 0.30 - 0.50 | S. A. Taylor & associates, Logan, Utah Vittum et al. (1963) Pew (1958) |
| Carrots | 0.55 - 0.65 | Pew (1958) |
| Broccoli, early | 0.45 - 0.55 | Pew (1958) |
| Broccoli, postbud | 0.60 - 0.70 | Pew (1958) |
| Cauliflower | 0.60 - 0.70 | Pew (1958) |
| <u>Fruit crops</u> | | |
| Lemons | 0.40 | A. W. Marsh, personal communication |
| Oranges | 0.20 - 1.00 | Stolzy et al. (1963) |
| Deciduous fruit | 0.50 - 0.80 | A. W. Marsh, personal communication Vissar (1959) |
| Avocados | 0.50 | Richards et al. (1962) |
| Grapes, early | 0.40 - 0.50 | A. W. Marsh, personal communication |
| Grapes, mature | 1.00 | A. W. Marsh, personal communication |
| Strawberries | 0.20 - 0.30 | A. W. Marsh, personal communication Marsh (1961) |
| Cantaloupe | 0.35 - 0.40 | Marsh (1961) Pew (1958) |
| Tomatoes | 0.80 - 1.50† | Vittum et al. (1958) Vittum et al. (1963) |
| Bananas | 0.30 - 1.50† | Schmuell (1953) |
| <u>Grain crops</u> | | |
| Corn, vegetative | 0.50 | S. A. Taylor & associates, Logan, Utah |
| Corn, ripening | 8.00 - 12.00 | S. A. Taylor & associates, Logan, Utah |
| Small grains, vegetative | 0.40 - 0.50 | S. A. Taylor & associates, Logan, Utah |
| Small grains, ripening | 8.00 - 12.00 | S. A. Taylor & associates, Logan, Utah |
| <u>Seed crops</u> | | |
| Alfalfa, prebloom | 2.00 | Taylor et al. (1955) |
| Alfalfa, bloom | 4.00 - 8.00 | |
| Alfalfa, ripening | 8.00 - 15.00 | |
| Seed carrots, 60-cm depth | 4.00 - 6.00‡ | Hawthorne (1951) |
| Onions, 7-cm depth | 4.00 - 6.00‡ | Hawthorne (1951) |
| Seed onions, 15-cm depth | 1.50 | |
| Lettuce, productive | 3.00‡ | Hawthorne & Pollard (1956) |
| Coffee requires short periods of low potential to break bud dormancy, followed by high water potential | | Alvim (1960) |

* Where two values for soil water suction are given, the lower suction value is used when the evaporative demand is high and the higher value when it is low; intermediate values are used when the atmospheric demand for evapotranspiration is intermediate. (these values are subject to revision as additional experimental data become available.)

† Based on converting 50% available water to water potential (soil suction) equivalents using curves for appropriate soil textures of Fig. 30-2.

‡ Based on converting 70% available water to water potential (soil suction) equivalents using curves for clay soils of Fig. 30-2.

‡ Resistance values were converted to water potential from calibration of similar plaster resistance units.

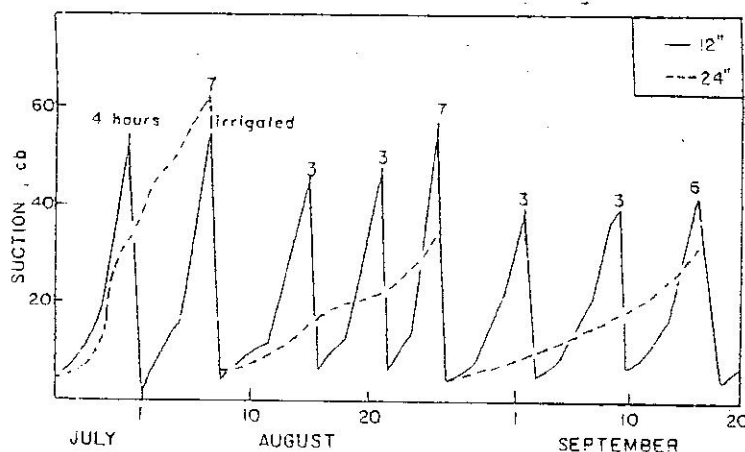

Fig. 3 Plotted of soil suction data during growing season. Tensiometer readings at a level near the bottom of the root zone (24 inches) is used to control the wetted depth and duration of water application.

level of the porous cup and water application should be stopped to avoid percolation loss.

Generally, at least one tensiometer should be placed in the active root zone for determining when to irrigate and another one near the bottom of the root zone for indicating depth of water penetration. When the root zone depth is less than 40 cm one tensiometer should be adequate and two or more should be used when the active roots are deeper than 40 cm. For plants with rooting depth deeper than 1.20 meters, it is desirable to have instruments at three different depths.

Tensiometers cannot be used to measure the entire range of available moisture in all soil types. However, they are the most suitable instrument for field measurement of moisture conditions in the wet range especially in sandy soil which large part of the moisture available to plants is held at a tension of less than one atmosphere. Tensiometers are less suited to use in fine-textured soils in which only a part of the available moisture is held at a tension of less than one atmosphere.

(3) Electrical Resistance Instrument This instrument measures moisture conditions in the soil based on the principle that a change in moisture content produces a change in electrical resistance property of the soil or of an instrument buried in the soil. The instrument that has been widely used consists of two electrodes made of straight wire or mesh screen of stainless steel. They are cast in plaster of paris or gypsum. When buried in soil, the plaster of paris or gypsum which are absorbent materials, will behave as a part of the soil and respond to changes in surrounding soil moisture contents. By measuring the changes in electrical resistance of the blocks, the surrounding soil moisture is read.

Other materials, such as nylon, fiber glass, and combinations of them with plaster of paris, also have been used as absorbent materials to enclosed electrodes. These materials provide greater sensitivity in the higher ranges of soil moisture than the plaster of paris block. However, under alternately wet and dry conditions, the contact between the resistance block and the soil particles may be poor. Consequently, the response of moisture changes in soil is often erratic and unreliable.

A serious problem in using plaster of paris or gypsum as an absorbent material is its' lack durability. If the soil is frequently irrigated or the blocks are placed in water logged soils, the resistance blocks made of plaster of paris or gypsum may disintegrate in one season.

Electrical resistance method for measuring soil moisture is sensitive to the present of salts in the soil profile and in irrigation water. The reading can also be affected by concentration of fertilizer. However, plastic and fiber blocks are more sensitive than gypsum blocks because the latter contain a saturated solution of calcium sulfate when wet. A salt concentration less than the level in the block has only slight effect on resistance of the unit.

Sensitivity of this method of soil moisture measurement depends on relative attraction of soil and block materials for water

at various moisture contents. Nylon blocks are more sensitive at tensions less than two atmospheres. Plaster of paris blocks function more effectively in the range between 1 and 15 atmospheres. However, none of the resistance blocks is as sensitive as the tensiometer within one atmosphere tension range. Since resistance readings vary with soil type, the blocks must be calibrated for the particular soil.

Number and locations of resistance blocks to be installed for irrigation scheduling purpose depend on crop rooting depth. Before installation, the blocks are saturated by soaking in water for few hours. A hole is drilled down to the desired level in the active root zone and the block is attached into the side of the hole at desired depth. Backfill and tamp the soil in place. A schematic sketch of typical installation of resistance blocks is presented in Fig. 4.

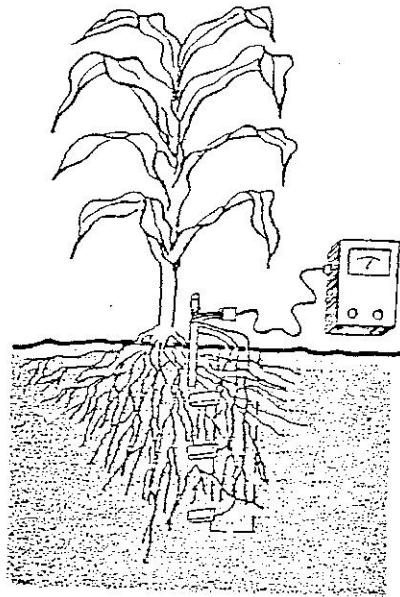

Fig. 4 Electrical resistance soil moisture meter

Resistance blocks and small portable electrical resistance meter are available commercially. The meter scales are calibrated to show both resistance and percentage of available moisture remaining in the soil. A reading of 100 indicates moisture level at field capacity and zero reading indicates moisture content at permanent wilting point. Plot of reading data with time during the growing season can be used to anticipate irrigation need several days in advance.

6.3 Irrigation Scheduling Based on Moisture-Accounting Method

The moisture accounting method is a book-keeping procedure for estimating soil moisture remaining in the root zone. The method is based on the principle that if the moisture content of a soil at any given time is known, the moisture content at any later time can be computed by adding water gains (from irrigation and/or effective rainfall) and subtracting water losses by crop evapotranspiration during the elapsed period. Irrigation will begin when the soil moisture in the root zone drops to an allowable depletion level.

This method requires a reliable estimation of daily evapotranspiration rate (ET_c) of the crop grown and daily measurement of rainfall at the site. Depending upon available data, the ET_c may be estimated by using modified Blaney-Criddle formula, radiation method, Penman method or evaporation pan method along with proper crop coefficients.

Computation usually is started on the day following a heavy rainfall or an irrigation which soil moisture content is assumed at field capacity. By knowing the daily rainfall and estimated ET_c the amount of available moisture in the root zone in each morning is computed by subtracting estimated ET_c for the previous day from the remaining moisture in the previous morning. Irrigation and rainfall of the previous day, if any, is added to the previous morning's balance. When the infiltrated rainfall causes the daily balance to exceed the field-capacity level, the excess is presumed to be lost and the daily balance is recorded as the field capacity level.

When the daily balance reaches the point at which the soil moisture depleted to the predetermined allowable limit, it is time to irrigate. The net depth of water to apply is the amount that has been depleted from the root zone. In the morning following irrigation the balance is again set at field capacity. The balance is computed daily until another irrigation is indicated.

Comparing to the soil moisture measurement methods, irrigation scheduling based on moisture accounting procedure has the advantage of requiring no costly equipment and very little labour. Nevertheless, its accuracy depends on estimates of water holding capacity of the soil, root zone depth, and accurate estimations of ET_c and effective rainfall. This weakness can be overcome by installing soil moisture measuring instruments at few representative locations to check the moisture level in the root zone as well as to indicate the depth to which rainfall or irrigation water has penetrated. With soil moisture measuring devices, the reliability of irrigation scheduling by moisture accounting procedure would be improved substantially.

Example 1

Following table is a typical moisture balance sheet for scheduling irrigation:

Month : April

Crop : Corn (Root Zone 1.0 m)

Available moisture in root zone : 120 mm.

Allowable depletion : 50 % (60 mm)

| Date | Estimated ET _c - mm | Effective Rainfall mm | Irrigation mm | Daily balance mm | Remarks |
|--------|-----------------------------------|-----------------------------|------------------|------------------------|---------------------|
| | | | | 36.5 | Balance from Feb. |
| Apr. 1 | 6.6 | | | 29.9 | |
| 2 | 6.1 | | | 23.8 | |
| 3 | 6.3 | | | 17.5 | |
| 4 | 6.8 | | | 10.7 | |
| 5 | 6.3 | | | 4.4 | |
| 6 | 6.6 | | 60 | 57.8 | |
| 7 | 6.6 | | | 51.2 | |
| 8 | 7.0 | | | 44.2 | |
| 9 | 6.8 | 32 | | 60.0 | 9.4 mm lost |
| 10 | 7.0 | | | 53.0 | |
| 11 | 6.6 | | | 46.4 | |
| 12 | 6.6 | | | 39.8 | |
| 13 | 6.8 | | | 33.0 | |
| 14 | 7.2 | | | 25.8 | |
| 15 | 6.3 | | | 19.5 | |
| 16 | 6.6 | | | 12.9 | |
| 17 | 4.8 | 12 | | 20.1 | |
| 18 | 4.1 | 14 | | 30.0 | |
| 19 | 6.1 | | | 23.9 | |
| 20 | 6.6 | | | 17.3 | |
| 21 | 6.8 | | | 10.5 | |
| 22 | 6.6 | | | 3.9 | |
| 23 | 6.3 | | 60 | 57.6 | |
| 24 | 5.3 | | | 52.3 | |
| 25 | 6.3 | | | 46.0 | |
| 26 | 6.1 | | | 39.9 | |
| 27 | 6.3 | | | 33.6 | |
| 28 | 6.3 | | | 27.3 | |
| 29 | 6.6 | | | 20.7 | |
| 30 | 6.6 | | | 14.1 | |
| Totals | | 58 | 120 | 14.1 | Carry over to May 1 |

REFERENCES

- Chang, Jen Hu., 1968, Climate and Agriculture, An Ecological Survey, Aldine Publishing Co, Chicago.
- Doorenbos, J. and A.H. Kassam, 1979, Yield Response to Water, FAO Irrigation and Drainage Paper No. 33, FAO Rome.
- Hagan, R.M., 1957, Water-Soil-Plant Relations, California Agriculture, April.
- Haise, H.R. and R.M. Hagan, 1967, Soil Plant, and Evaporative Measurements as Criteria for Scheduling Irrigation, Chapt. 30 in: Irrigation of Agricultural Lands, Hagen, et. al., Eds, Monograph No. 11, American Society of Agronomy, Michigan.
- Israelsen, O.W. and V.E. Hansen, 1967, Irrigation Principles and Practices, Third Edition, John Wiley and sons. Inc.
- Marsh, A.W., Questions and Answers about Tensiometer and Their Use, Agricultural Extension, University of California, No date.
- Stegman, E.C., 1983, Irrigation Scheduling: Applied Timing Criteria, Advances in Irrigation, Vol. 2, Academic Press Inc.
- U.S. Department of Agriculture, 1955, Water, The Year Book of Agriculture 1955, U.S. Government Printing Office, Washington D.C.
- U.S. Department of Agriculture, Soil Conservation Service, 1964. Soil-Plant-Water Relationships, SCS National Engineering Handbook, Section 15, Chapt. 1., U.S. Government Printing Office, Wahsington, D.C.

Training Course on Irrigation Design and Management

(August 87)

Exercise No. 2

Irrigation Water Requirements and Irrigation Scheduling

1. The climatological data of Khon Kaen are given in Table 2, determine the potential evapotranspiration (mm/day) for June by using:
 - (1) Improved Blaney Criddle Formula,
 - (2) Radiation Method,
 - (3) Penman Method, and
 - (4) Pan Evaporation Method.

2. Determine the potential evapotranspiration of Khon Kaen for July, August and September using the data from Table 2. The method of calculation is your choice.

3. A maize is to be grown in an area of Khon Kaen province. The local information shows that the length of growing season of maize is approximately 110 days and the initial, crop development, mid-season and late season stages take 15, 30, 35 and 30 days respectively.

Determine the crop coefficients of maize, if the irrigation frequency during the initial stage is 7 days and the planting date is June 10.

4. Calculate the evapotranspiration of maize in June, July, August and September by using the information from (1), (2) and (3).

5. The soil investigation revealed that soils in the area (to grow maize) has loamy in texture. The field capacity and permanent wilting point are 22 and 10 % on dry weight basis respectively. The apparent specific gravity is 1.40. The data from the agricultural experimentation of Khon Kaen province reported that the average rooting depths of maize during the initial, crop development, mid-season and late-season stages are 10, 25, 40 and 40 cm. accordingly. If the allowable depletion at any stage of crop development is 50 % of available moisture:
- (1) What are the irrigation frequencies.
 - (2) What is the tentative irrigation schedule for this maize?
6. Determine the average effective rainfall during June to September by using the relationship (Table) of USDA.
7. Assume no groundwater contribution to the root zone of maize and the initial soil moisture (June 10) is at the permanent wilting point. What is the net irrigation requirements of the maize ?
8. If the planting area is 50 hectares, the application efficiency is 70 % and the distribution efficiency is 65 %, what is the water delivery rate to the farm at the peak use demand?

Training Course on Irrigation Design and Management

(August 87)

Solution to Exercise No.2

Irrigation Water Requirements and Irrigation Scheduling

1. Find ET_0 (mm/day) for June using the climatological data of Khon Kaen in Table 2.

(1) Improved Blaney Criddle Formula, Eq. (5)

From Table 2 (p. 18)

Khon Kaen Province

Latitude : 16°N

Month : June

Mean daily temperature (T) = 28.7°C

Min relative humidity (RH_{min}) = 60 %

Mean relative humidity (RH_{mean}) = 76 %

Mean sunshine hours = 196.9 hr./month

Mean wind speed = 3.9 knots

Height of wind vane above the ground = 10.55 m.

Determine

$$p \text{ (from Table 1, p. 15)} = 0.29$$

$$f = p(0.46 T + 8) \quad \text{mm.}$$

$$= 0.29 (0.46 \times 28.7 + 8) \quad \text{"}$$

$$= 6.15 \quad \text{"}$$

$$n = \frac{196.9}{30} \quad \text{hours/day}$$

$$= 6.56 \quad \text{"}$$

$$N \text{ (from Table 4)} = 13.1 \quad \text{"}$$

$$\frac{n}{N} = \frac{6.56}{13.1} = 0.50$$

$$U_{10.55} = 3.9 \quad \text{knots}$$

$$= 3.9 \times 0.5148 \quad \text{m/sec}$$

$$= 2.01 \quad \text{"}$$

$$\begin{aligned}
 U_2 &= U_{10.55} \left(\frac{2}{10.55} \right)^{0.2} && \text{m/sec} \\
 &= 2.01 \left(\frac{2}{10.55} \right)^{0.2} && \text{"} \\
 &= 1.44 && \text{"}
 \end{aligned}$$

From Fig. 8 (p. 16)

Use Block IX, Line I

$$\begin{aligned}
 f &= p (0.46T + 8) = 6.15 && \text{mm.} \\
 ET_o &= 3.9 && \text{mm/day}
 \end{aligned}$$

Use Block VI, Line I

$$ET_o = 4.9 \quad \text{mm/day}$$

$$\begin{aligned}
 ET_o \text{ (average at } \frac{n}{N} = 0.5) &= 3.9 + \frac{(4.9 - 3.9) \times 0.5}{2.5} \\
 &= 4.1 && \text{mm/day}
 \end{aligned}$$

Ans.

(2) Radiation Method, Eq. (7)

$$\begin{aligned}
 ET_o &= C(W.R_s) && \text{mm/day} \\
 R_s &= (0.25 + 0.5 \frac{n}{N}) R_a && \text{"} \\
 \frac{n}{N} &= 0.50 \\
 R_a &= \text{Extra Terrestrial Radiation from Table 3} \\
 &\quad \text{(p. 20)} \\
 &= 15.9 && \text{mm/day} \\
 R_s &= (0.25 + 0.5 \times 0.5) 15.9 && \text{"} \\
 &= 7.95 && \text{"} \\
 W &= \text{Weighting factor for } R_a \\
 &\quad \text{from Table 5 (p. 21)} \\
 &= 0.78 \text{ (for attitude 165 m, } T = 28.7^\circ\text{C)} \\
 W.R_s &= 0.78 \times 7.95 && \text{mm/day} \\
 &= 6.20 && \text{"}
 \end{aligned}$$

Fig. 9 (p. 24), for $RH_{\text{mean}} = 76\%$ and

$$U_2 = 1.44 \quad \text{m/sec}$$

Use Block IV, Line I

$$ET_o = 4.8 \quad \text{mm/day}$$

Ans.

(3) Penman Method, Eq. (10)

$$ET_o = W \cdot R_n + (1 - W) E_a \quad \text{mm/day}$$

$$W \text{ (Table 5)} = 0.78$$

$$R_n = \text{net radiation in mm/day}$$

$$= (1 - \alpha) R_s - R_b$$

$$\alpha = \text{reflection coefficient} = 0.23$$

$$R_s = 7.95 \quad \text{mm/day}$$

$$R_b = \sigma T_K^4 (0.34 - 0.044 \sqrt{e_d}) (0.10 + 0.90 \frac{n}{N}) \quad \text{mm/day}$$

$$\sigma T_K^4 = \text{black body reflection from Table 7, p.26}$$

$$= 16.7 \quad \text{mm/day}$$

$$RH_{\text{mean}} = 76\%$$

$$e_a = \text{saturation vapor pressure from Table 8, p. 27}$$

$$= 39.14 \quad \text{millibars}$$

$$e_d = \frac{RH_{\text{mean}} \times e_a}{100}$$

$$= \frac{76 \times 39.14}{100}$$

$$= 29.75 \quad \text{millibars}$$

$$R_b = 16.7(0.34 - 0.044 \sqrt{29.75})(0.1 + 0.9 \times 0.5) \quad \text{mm/day}$$

$$= 0.92 \quad "$$

$$R_n = (1 - 0.23)7.95 - 0.92 \quad "$$

$$= 5.20 \quad "$$

$$\begin{aligned}
 E_a &= \text{Aerodynamic component} \\
 &= 0.265 (1.0 + 0.0062 U_2) (e_a - e_d) \quad \text{mm/day} \\
 U_2 &= 1.44 \text{ m/sec} = \frac{1.44}{1000} \times 24 \times 3600 = 124.4 \text{ km/day} \\
 &\approx 0.265 (1.0 + 0.0062 \times 124.4) (39.14 - 29.75) \quad " \\
 &= 4.41 \quad \text{mm/day} \\
 ET_o &= W.R_n + (1 - W)E_a \quad " \\
 &= 0.78 \times 5.2 + (1 - 0.78)4.41 \quad " \\
 &= 5.07 \quad " \quad \underline{\text{Ans.}}
 \end{aligned}$$

(4) Pan Evaporation Method, Eq. (16)

$$\begin{aligned}
 ET_o &= K_p \cdot E_{pan} \quad \dots\dots\dots " \\
 \text{Mean evaporation (Table 2), } E_{pan} & \\
 &= 168.5 \quad \text{mm/month} \\
 &= \frac{168.5}{30} \quad " \\
 &= 5.62 \quad "
 \end{aligned}$$

$$K_p = \text{pan coefficient (Table 10, p.34)}$$

Assume Case A with green crop distance of 100 m.

$$RH_{\text{mean}} = 76 \%$$

$$24 \text{ hr wind} = 124.4 \quad \text{km/day}$$

$$K_p = 0.85$$

$$\begin{aligned}
 ET_o &= 0.85 \times 5.62 \quad \text{mm/day} \\
 &= 4.78 \quad " \quad \underline{\text{Ans.}}
 \end{aligned}$$

2. Use pan evaporation method to calculate ET_o for July, August and September in Khon Kaen Area.

| | July | August | September |
|---|--------------------|--------------------|------------------|
| E_{pan} (Table 2), mm/month | 171.2 | 151.9 | 138.0 |
| E_{pan} , mm/day | 171.2/31 = 5.52 | 151.9/31 = 4.90 | 138/30 = 4.60 |
| Assume Case A with the green crop distance of 100 m. | Yes | Yes | Yes |
| RH_{mean} , % | 77 | 80 | 82 |
| Mean wind speed, knots | 4.1 | 3.8 | 2.8 |
| 24 hr wind at 2 m. above the ground, km/day (31.895xknots) | 130.8 | 121.2 | 89.3 |
| K_p | 0.85 | 0.85 | 0.85 |
| ET_o , mm/day | 0.69 | 4.17 | 3.91 |

3. Data

A maize is to be grown in Khon Kaen area.

| | | | |
|--------------------------|---|-----|------|
| Length of growing season | = | 110 | days |
| initial stage | = | 15 | " |
| crop development stage | = | 30 | " |
| mid-season stage | = | 35 | " |
| late season stage | = | 30 | " |

Determine crop coefficients

Planting data is June 10

irrigation frequency during initial stage = 7 days

Fig. 12 (p. 38), if $ET_o = 4.78$ mm/day s
 K_c (initial) = 0.5

From Table 12 (p. 40),

K_c (mid season) = 1.05

K_c (late season) = 0.55

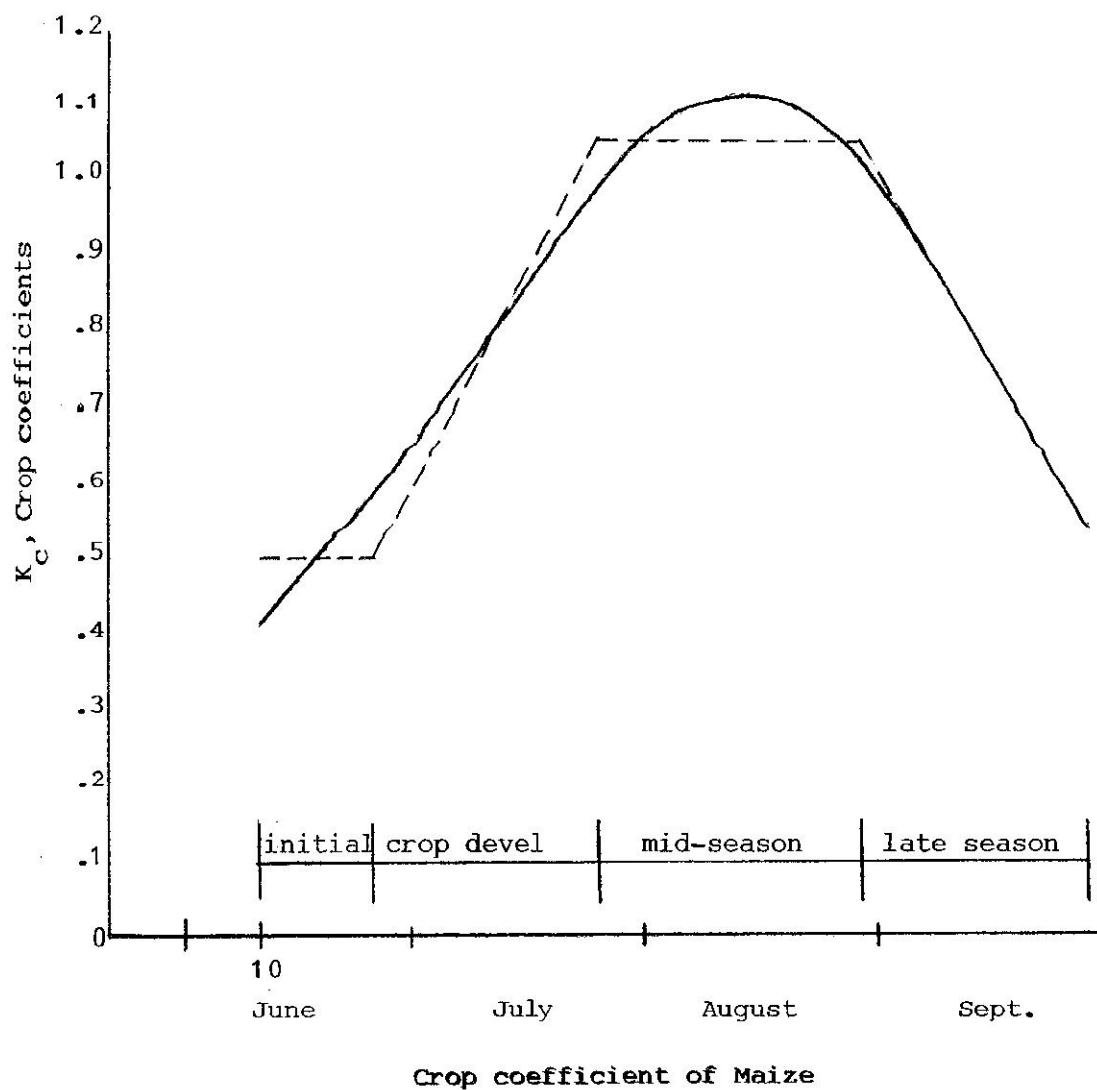

4. Calculate ET_c of maize in June to September

| Month | June | July | August | September |
|---|------|-------|--------|-----------|
| (1) No. of days in the month | 21 | 31 | 31 | 27 |
| (2) K_c at the middle of the period | 0.52 | 0.85 | 1.12 | 0.80 |
| (3) ET_o (Pan Evaporation method), mm/day | 4.78 | 4.69 | 4.17 | 3.91 |
| (4) $ET_c = K_c \cdot ET_o$, mm/day | 2.49 | 3.99 | 4.67 | 3.13 |
| (5) ET_c mm. | 52.3 | 123.7 | 144.8 | 84.5 |

Irrigation Schedule

| Irrigation No. | Irrigation Frequency, days | Irrigation Date |
|----------------|----------------------------|-----------------|
| 1 | 3 | Jun. 10 |
| 2 | 3 | Jun. 13 |
| 3 | 3 | Jun. 16 |
| 4 | 3 | Jun. 19 |
| 5 | 3 | Jun. 22 |
| 6 | 3 | Jun. 25 |
| 7 | 5 | Jun. 30 |
| 8 | 5 | Jul. 5 |
| 9 | 5 | Jul. 10 |
| 10 | 5 | Jul. 15 |
| 11 | 5 | Jul. 20 |
| 12 | 5 | Jul. 25 |
| 13 | 7 | Aug. 1 |
| 14 | 7 | Aug. 8 |
| 15 | 7 | Aug. 15 |
| 16 | 7 | Aug. 22 |
| 17 | 7 | Aug. 29 |
| 18 | 10 | Sep. 8 |
| 19 | 10 | Sep. 18 |

5.

| | Initial State | Crop development Stage | | Mid - season Stage | | Late - season Stage | |
|--|---------------|------------------------|-----------|--------------------|------------|---------------------|-----------|
| | | Jun.10-24 | Jun.25-30 | July 1-24 | July 25-31 | Aug.1-28 | Aug.29-31 |
| (1) No. of days | 15 | 6 | 24 | 7 | 28 | 3 | 27 |
| (2) Root zone depth (D), cm. | 10 | 25 | | 40 | | 40 | |
| (3) Available moisture, mm. = $\frac{(22-10) \times 1.4 D(\text{cm}) \times 10}{100}$ | 16.8 | 42 | | 67.2 | | 67.2 | |
| (4) Allowable depletion, mm. [50 % (3)] | 8.4 | 21 | | 33.6 | | 33.6 | |
| (5) ET_c in each month, mm/day | 2.5 | 2.5 | 4.0 | 4.0 | 4.7 | 4.7 | 3.1 |
| (6) ET_c (average in each stage), mm/day | 2.5 | 3.7 | | 4.6 | | 3.3 | |
| (7) Irrigation frequencies, days | 3 | 5 | | 7 | | 10 | |

6. Determine the effective rainfall using Table 13 (p. 45)

| | June | July | Aug. | Sept. |
|---|-------|-------|-------|-------|
| (1) Mean rainfall, mm/month | 180.8 | 156.5 | 188.3 | 276.9 |
| (2) ET_c , mm/day | 2.49 | 3.99 | 4.67 | 3.13 |
| , mm/month | 74.7 | 123.7 | 144.8 | 93.9 |
| (3) Unadjusted effective rainfall, mm/month | 74.7 | 103.9 | 124.2 | 93.9 |
| (4) Weighted average allowable depletion in mm. | 12 | 23.8 | 33.6 | 33.6 |
| (5) Adjustment factor | 0.74 | 0.79 | 0.84 | 0.84 |
| (6) Adjusted effective rainfall, mm/month | 55.3 | 82.1 | 104.3 | 78.9 |
| , mm/day | 1.84 | 2.65 | 3.36 | 2.63 |

7. Assume no groundwater contribution to the root zone of maize and the initial soil moisture content on June 10 is at the permanent wilting point. Net irrigation water requirements (I_N)

$$= ET_c - \text{Effective Rainfall}$$

| | June | July | Aug. | Sept. |
|----------------------------|------|------|------|-------|
| No. of days | 21 | 31 | 31 | 27 |
| ET_c , mm/day | 2.49 | 3.99 | 4.67 | 3.13 |
| Effective Rainfall, mm/day | 1.84 | 2.65 | 3.36 | 2.63 |
| I_N , mm/day | 0.65 | 1.34 | 1.31 | 0.5 |
| I_N , mm/month | 13.7 | 41.5 | 40.6 | 13.5 |

Net irrigation water requirements

$$= 13.7 + 41.5 + 40.6 + 13.5 \quad \text{mm.}$$

$$= 109.3 \quad \text{mm.} \quad \underline{\text{Ans.}}$$

8. Area = 50 hectares

Application efficiency (E_a) = 70 %

Distribution efficiency (E_d) = 65 %

Peak use demand from 7 = 1.34 mm/day

(consider that the effective rainfall reduces the irrigation water requirements)

$$Q = \frac{A \times D}{t} \times \frac{1}{E_a \cdot E_d}$$

$$Q = 50 \times 10000 \times \frac{1.34}{1000} \times \frac{1}{0.7 \times 0.65} \quad \text{m}^3/\text{day}$$

$$= 1472.5 \quad "$$

If the working hour is 8 hr/day

$$Q = \frac{1472.5 \times 8}{24} = 490.8 \quad \text{m}^2/\text{hr}$$

$$= 0.136 \quad \text{m}^3/\text{sec}$$

$$= 13 \quad \text{l/s}$$

Ans.